

//04



miлоox®

www.miloox.com  
www.miloox.it

# INDEX

1744.12	EBE	305	1744.99	POMI'	133
1744.13	EBE	307	1744.100	POMI'	135
1744.14	ADONE	309	1744.101	POMI'	127
1744.15	ADONE	311	1744.102	POMI'	125
1744.16	FIFTY	297	1744.103	POMI'	137
1744.17	FIFTY	295	1744.104	POMI'	129
1744.18	FIFTY	299	1744.105	POMI'	131
1744.19	FIFTY	291	1744.108	SAMOI	349
1744.34	BOMBO	315	1744.109	SAMOI	351
1744.35	BOMBO	327	1744.110	SAMOI	353
1744.36	BOMBO	331	1744.124	BOMBO	319
1744.37	BOMBO	329	1744.125	BOMBO	321
1744.38	COCHI	301	1744.126	BOMBO	323
1744.62	JUGEN	263	1744.127	BOMBO	325
1744.63	JUGEN	261	1744.139	ALADINO	from 213 to 215
1744.64	JUGEN	249	1744.141	ALADINO	from 216 to 221
1744.65	JUGEN	255	1744.144	ALADINO	from 222 to 229
1744.66	JUGEN	251	1744.149	ALADINO	from 230 to 237
1744.67	JUGEN	253	1744.150	LUNAR	267
1744.68	JUGEN	247	1744.151	LUNAR	269
1744.70	JUGEN	245	1744.152	LUNAR	271
1744.71	JUGEN	265	1744.153	LUNAR	273
1744.72	JUGEN	257	1744.154	LUNAR	275
1744.73	JUGEN	259	1744.155	LUNAR	277
1744.74	JUGEN	369	1744.156	LOLLIPOP	333
1744.75	JUGEN	371	1744.157	LOLLIPOP	335
1744.76	JUGEN	373	1744.158	LOLLIPOP	337
1744.77	NEW KENGO	343	1744.164	COSMO	139
1744.79	NEW KENGO	347	1744.165	COSMO	141
1744.80	NEW KENGO	345	1744.166	COSMO	143
1744.81	NEW KENGO	341	1744.167	COSMO	145 and 149
1744.83	JUGEN CROMO	363	1744.168	COSMO	155
1744.84	JUGEN CROMO	365	1744.169	COSMO	153
1744.85	JUGEN CROMO	367	1744.170	COSMO	147
1744.88	X-RAY	183	1744.171	COSMO	151
1744.89	HAT	279	1744.172	ALADINO	from 238 to 243
1744.90	X-RAY	187	1744.174	BABELE	from 77 to 79
1744.91	HAT	283 and 287	1744.175	MIKADO	from 7 to 11
1744.92	HAT	289	1744.176	MIKADO	from 13 to 15
1744.93	HAT	280 and 285	1744.177	MIKADO	from 17 to 21
1744.94	X-RAY	183	1744.178	MIKADO	from 23 to 25
1744.95	X-RAY	187	1744.179	MIKADO	27
1744.96	X-RAY	185	1744.180	POT	from 85 to 87
1744.97	X-RAY	185	1744.181	POT	from 89 to 91
1744.98	POMI'	123	1744.182	POT	from 93 to 95

# INDEX

1744.187	MOSE	from 53 to 55 and 74	1744.M.133	X-RAY	195
1744.188	MOSE	from 53 to 55 and 74	1744.M.134	X-RAY	from 210 to 211
1744.189	MOSE	from 53 to 55 and 74	1744.M.135	X-RAY	from 210 to 211
1744.190	MOSE	from 57 to 59 and 74	1744.M.136	X-RAY	from 210 to 211
1744.191	MOSE	from 57 to 59 and 74	1744.M.183	MOSE	75
1744.192	MOSE	from 57 to 59 and 74	1744.M.184	MOSE	75
1744.193	MOSE	from 61 to 65 and 74	1744.M.185	MOSE	75
1744.194	MOSE	from 61 to 65 and 74	1744.M.186	MOSE	75
1744.195	MOSE	from 61 to 65 and 74	1744.V.118	X-RAY	from 210 to 211
1744.196	MOSE	47	1744.V.119	X-RAY	from 210 to 211
1744.197	MOSE	from 49 to 51	1744.V.120	X-RAY	from 210 to 211
1744.198	JUGEN BLACK EDITION	163	1744.V.128	X-RAY	from 210 to 211
1744.199	JUGEN BLACK EDITION	181	1744.V.129	X-RAY	from 210 to 211
1744.200	JUGEN BLACK EDITION	165	1744.V.130	X-RAY	from 210 to 211
1744.201	JUGEN BLACK EDITION	175	PRICE LIST		375
1744.202	JUGEN BLACK EDITION	171			
1744.203	JUGEN BLACK EDITION	173	1744.V.12		305
1744.204	JUGEN BLACK EDITION	169	1744.V.13		307
1744.205	JUGEN BLACK EDITION	157	1744.V.14		309
1744.206	JUGEN BLACK EDITION	159	1744.V.15		311
1744.207	JUGEN BLACK EDITION	177	1744.V.16		297
1744.208	JUGEN BLACK EDITION	179	1744.V.19		291
1744.209	ALBA	from 81 to 83	1744.V.34		315
1744.210	JUGEN CROMO	357	1744.V.35		327
1744.211	JUGEN CROMO	359	1744.V.38		301
1744.212	JUGEN CROMO	361	1744.V.62		263
1744.213	NEORETRO	from 97 to 101	1744.V.63		261
1744.214	NEORETRO	from 103 to 107	1744.V.64		249
1744.215	NEORETRO	from 109 to 113	1744.V.66		251
1744.216	NEORETRO	from 115 to 117	1744.V.98		123
1744.217	NEORETRO	from 119 to 121	1744.V.128.INT.SAT		195
1744.218	MIKADO TRANSPARENT	from 29 to 31	1744.V.129.INT.SAT		195
1744.219	MIKADO TRANSPARENT	from 33 to 37	1744.V.130.INT.SAT		195
1744.220	MIKADO TRANSPARENT	from 39 to 41	1744.V.139		213
1744.221	MIKADO TRANSPARENT	43	1744.V.150		267
1744.222	MIKADO TRANSPARENT	45	1744.V.156		333
1744.M.38	COCHI	303	1744.V.164		139
1744.M.40	EBE+ADONE	313	1744.V.174		77
1744.M.47	FIFTY	293	1744.V.175		7
1744.M.50	LOLLIPOP	339	1744.V.187		53
1744.M.51	BOMBO	317	1744.V.209		81
1744.M.52	SAMOI	355	1744.V.213		97
1744.M.128	X-RAY	from 210 to 211	PRICE LIST		389
1744.M.131	X-RAY	195			
1744.M.132	X-RAY	195			

**miloox**  
Designed by  
**Davide  
Negri**

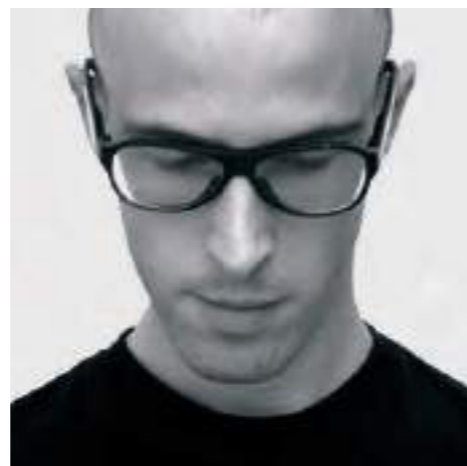

**Architetto e designer**, laureato alla Facoltà di Architettura del Politecnico di Milano.

Nel 2001 fonda il proprio studio, occupandosi principalmente di furniture, lighting, interior design e allestimenti. Ha conseguito diversi riconoscimenti, fra cui il la menzione progetto giovane del Compasso d'Oro, l'AD Architectural Digest Young Designers Award, la Menzione Speciale Young & Design Award. È coordinatore e docente del Dipartimento di Product Design dell'Università IAAD in Torino e Bologna.

Ha insegnato presso IED e al Politecnico di Milano e collabora con, Sforzin Illuminazione, dando risalto al Brand Miloox. Attualmente si occupa di progettazione a 360°: design di prodotto, art direction e consulenza strategica per l'innovazione e lo sviluppo di nuovi brand in sintonia con i mercati contemporanei.

**Architect and designer**, graduated from the Faculty of Architecture of the Politecnico di Milano. In 2001 he founded his own firm, dealing mainly with furniture, lighting, interior design and fittings. He has won several awards, including the Compasso d'Oro Young Project Mention, the AD Architectural Digest Young Designers Award and the Special Mention Young & Design Award.

He is coordinator and lecturer at the Department of Product Design of the IAAD University in Turin and Bologna.

He has taught at IED and at Politecnico di Milano and collaborates with Sforzin Illuminazione, enhancing the Brand Miloox. He currently deals with design as a whole: product design, art direction and strategic consulting for innovation and development of new brands in sync with contemporary markets.

**Architetto e designer**, Architekt und Designer, hat am Polytechnikum von Mailand Architektur studiert. Im Jahr 2001 gründet er sein eigenes Studio, das sich hauptsächlich mit Möbeln, Beleuchtung, Innenarchitektur und Ausstattung beschäftigt. Er hat mehrere Preise gewonnen, darunter den Compasso d'Oro für junge Projekte, den AD Architectural Digest Young Designers Award und zwar den Special Mention Young & Design Award. Er ist Koordinator und Dozent im Fachbereich für Produktdesign der IAAD-Universität in Turin und Bologna. Er hat am IED und am Polytechnikum von Mailand arbeiten mit Sforzin Illuminazione, Hervorheben der Marke Miloox. Derzeit beschäftigt er sich mit Design um 360 Grad: Produktdesign, Art Direction und strategische Beratung zur Innovation und Entwicklung neuer Marken im Einklang mit den heutigen Märkten.



Lampada da parete o soffitto con montatura in metallo verniciato a polvere nero soft touch. Diffusore in vetro soffiato bianco latte diametro 14 cm. La rotazione del braccio secondario consente di scegliere la posizione preferita.

Wall or ceiling lamp with black soft touch powder coated metal frame. Milky white blown glass diffuser, diameter 14 cm. The rotation of the secondary arm allows to choose the preferred position.

Wand- oder Deckenleuchte mit schwarzem, pulverbeschichtetem Metallrahmen in Softtouch-Ausführung. Diffuser aus milchig-weiß geblasenem Glas, Durchmesser 14 cm. Durch ein Drehen des sekundären Arms kann man die Leuchte in die gewünschte Stellung bringen.



# MIKADO

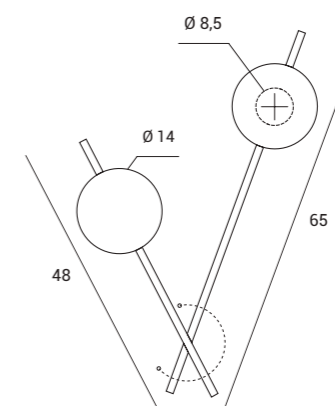

- + Uscita cavo elettrico
- + Power Supply
- + Brennstelle



Source

G9

Power

2 x max 28w

1744.175



## ESEMPI DI POSSIBILI CONFIGURAZIONI / EXAMPLES OF POSSIBLE CONFIGURATIONS / GESTALTUNGSMÖGLICHKEITEN

La rotazione del braccio secondario consente di scegliere la posizione preferita.  
The rotation of the secondary arm allows to choose the preferred position.  
Die Gestellarme ermöglichen das Einstellen der optimalen Leuchtposition.

- + Uscita cavo elettrico
- + Power Supply
- + Brennstelle

CONFIGURAZIONE  
2 LUCI

2 LIGHTS  
CONFIGURATION

EINSTELLEN VON  
2 LEUCHTEN

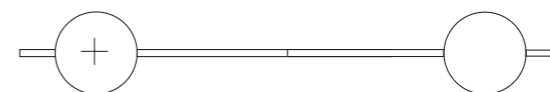

CONFIGURAZIONE  
2 LUCI

2 LIGHTS  
CONFIGURATION

EINSTELLEN VON  
2 LEUCHTEN

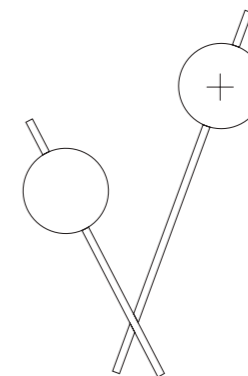

CONFIGURAZIONE  
2 LUCI

2 LIGHTS  
CONFIGURATION

EINSTELLEN VON  
2 LEUCHTEN

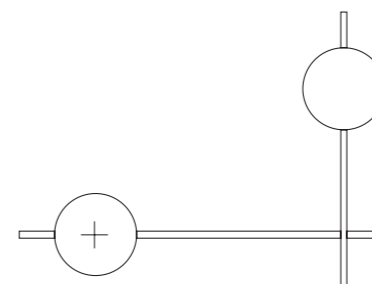

# MIKADO

1744.175

WINNER



...E MOLTO ALTRO  
...AND MANY MORE  
...UND VIELE WEITERE MÖGLICHKEITEN





Lampada a parete o soffitto con montatura in metallo verniciato a polvere nero soft touch. Diffusore in vetro soffiato bianco latte diametro 14 cm. La rotazione dei bracci secondari consente di scegliere la posizione preferita.

Wall or ceiling lamp with black soft touch powder coated metal frame. Milky white blown glass diffuser, diameter 14 cm. The rotation of the secondary arm allows to choose the preferred position.

Wand- oder Deckenleuchte mit schwarzem, pulverbeschichtetem Metallrahmen in Softtouch-Ausführung. Diffuser aus milchig-weiß geblasenem Glas, Durchmesser 14 cm. Durch ein Drehen des sekundären Arms kann man die Leuchte in die gewünschte Stellung bringen.



# MIKADO

1744.176

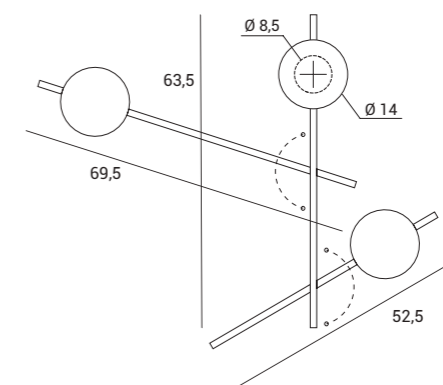

+ Uscita cavo elettrico  
+ Power Supply  
+ Brennstelle



Source

G9

Power

3 x max 28w



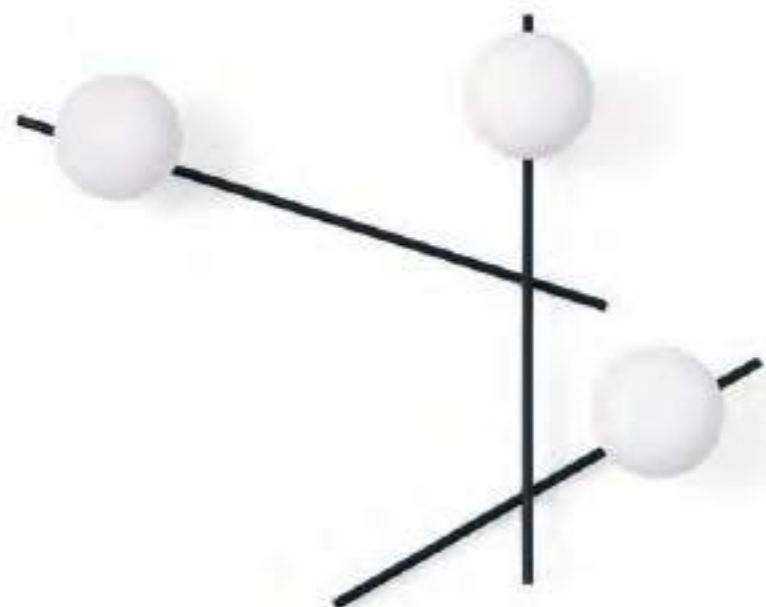
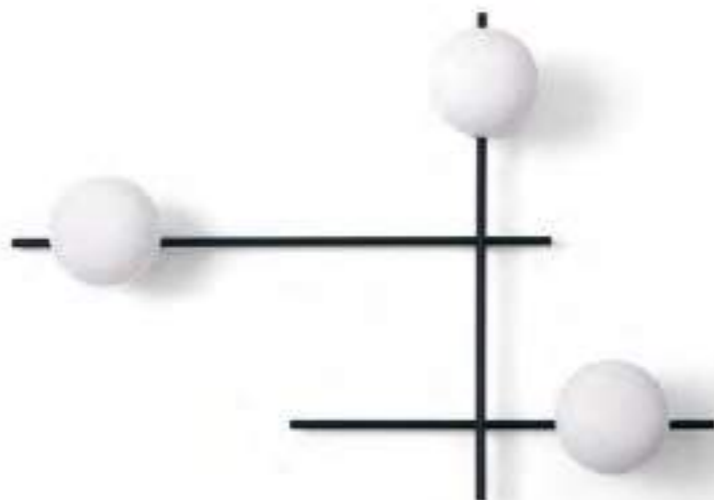

### ESEMPI DI POSSIBILI CONFIGURAZIONI / EXAMPLES OF POSSIBLE CONFIGURATIONS / GESTALTUNGSMÖGLICHKEITEN

La rotazione dei bracci secondari consente di scegliere la posizione preferita.  
The rotation of the secondary arms allows to choose the preferred position.  
Die Gestellarme ermöglichen das Einstellen der optimalen Leuchtposition.

- + Uscita cavo elettrico
- + Power Supply
- + Brennstelle

CONFIGURAZIONE  
3 LUCI

3 LIGHTS  
CONFIGURATION

EINSTELLEN VON  
3 LEUCHTEN

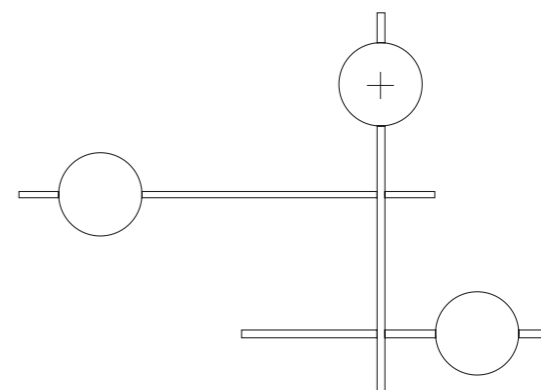

CONFIGURAZIONE  
3 LUCI

3 LIGHTS  
CONFIGURATION

EINSTELLEN VON  
3 LEUCHTEN

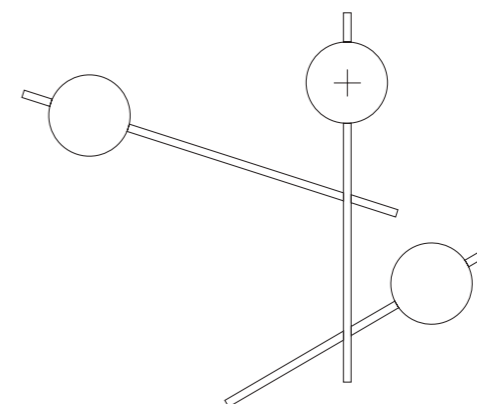

# MIKADO

1744.176

WINNER



...E MOLTO ALTRO  
...AND MANY MORE  
...UND VIELE WEITERE MÖGLICHKEITEN



Lampada a parete o soffitto con montatura in metallo verniciato a polvere nero soft touch. Diffusore in vetro soffiato bianco latte diametro 14 cm. La rotazione dei bracci secondari consente di scegliere la posizione preferita.

Wall or ceiling lamp with black soft touch powder coated metal frame. Milky white blown glass diffuser, diameter 14 cm. The rotation of the secondary arm allows to choose the preferred position.

Wand- oder Deckenleuchte mit schwarzem, pulverbeschichtetem Metallrahmen in Softtouch-Ausführung. Diffuser aus milchig-weiß geblasenem Glas, Durchmesser 14 cm. Durch ein Drehen des sekundären Arms kann man die Leuchte in die gewünschte Stellung bringen.



# MIKADO

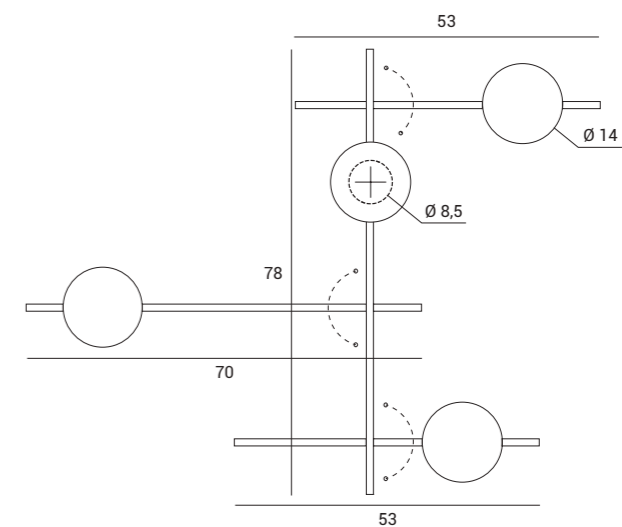

+ Uscita cavo elettrico  
+ Power Supply  
+ Brennstelle



Source

G9

Power

4 x max 28w

1744.177



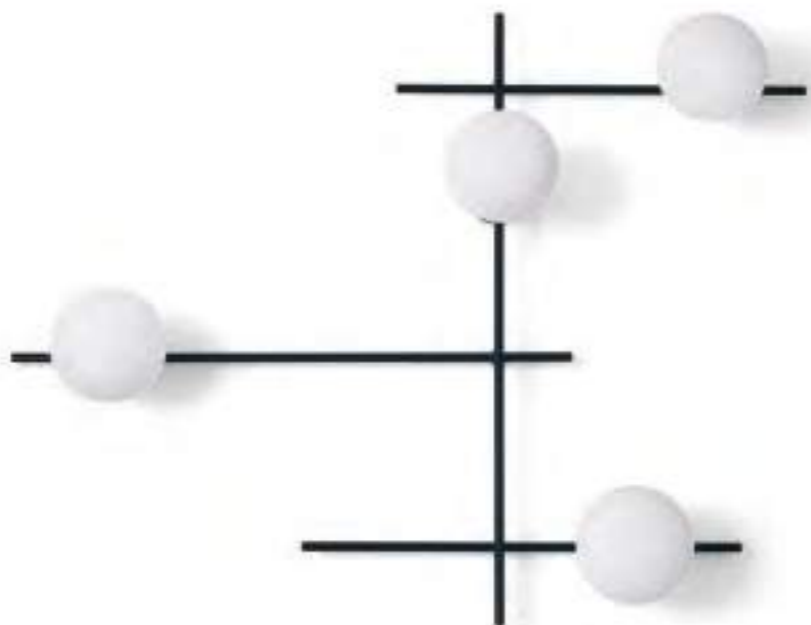

# MIKADO

1744.177

WINNER



## ESEMPI DI POSSIBILI CONFIGURAZIONI / EXAMPLES OF POSSIBLE CONFIGURATIONS / GESTALTUNGSMÖGLICHKEITEN

La rotazione dei bracci secondari consente di scegliere la posizione preferita.  
The rotation of the secondary arms allows to choose the preferred position.  
Die Gestellarme ermöglichen das Einstellen der optimalen Leuchtposition.

- + Uscita cavo elettrico
- + Power Supply
- + Brennstelle

CONFIGURAZIONE  
4 LUCI

4 LIGHTS  
CONFIGURATION

EINSTELLEN VON  
4 LEUCHTEN

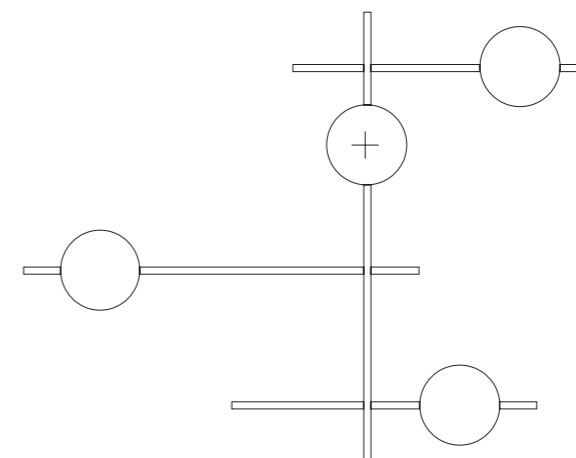

CONFIGURAZIONE  
4 LUCI

4 LIGHTS  
CONFIGURATION

EINSTELLEN VON  
4 LEUCHTEN

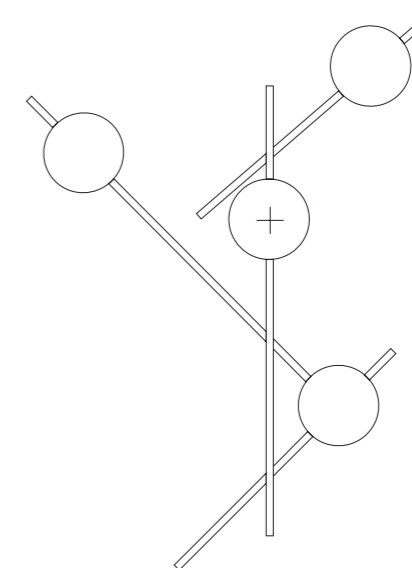

...E MOLTO ALTRO  
...AND MANY MORE  
...UND VIELE WEITERE MÖGLICHKEITEN



Lampada a parete o soffitto.  
Montatura in metallo verniciato a  
polvere nero soft touch. Diffusore in  
vetro soffiato bianco latte diametro 14  
cm. La rotazione dei bracci secondari  
consente di scegliere la posizione  
preferita.

Wall or ceiling lamp with black soft  
touch powder coated metal frame.  
Milky white blown glass diffuser,  
diameter 14 cm. The rotation of the  
secondary arm allows to choose the  
preferred position.

Wand- oder Deckenleuchte mit  
schwarzem, pulverbeschichtetem  
Metallrahmen in Softtouch-Ausführung.  
Diffuser aus milchig-weiß geblasenem  
Glas, Durchmesser 14 cm. Durch ein  
Drehen des sekundären Arms kann man  
die Leuchte in die gewünschte Stellung  
bringen.

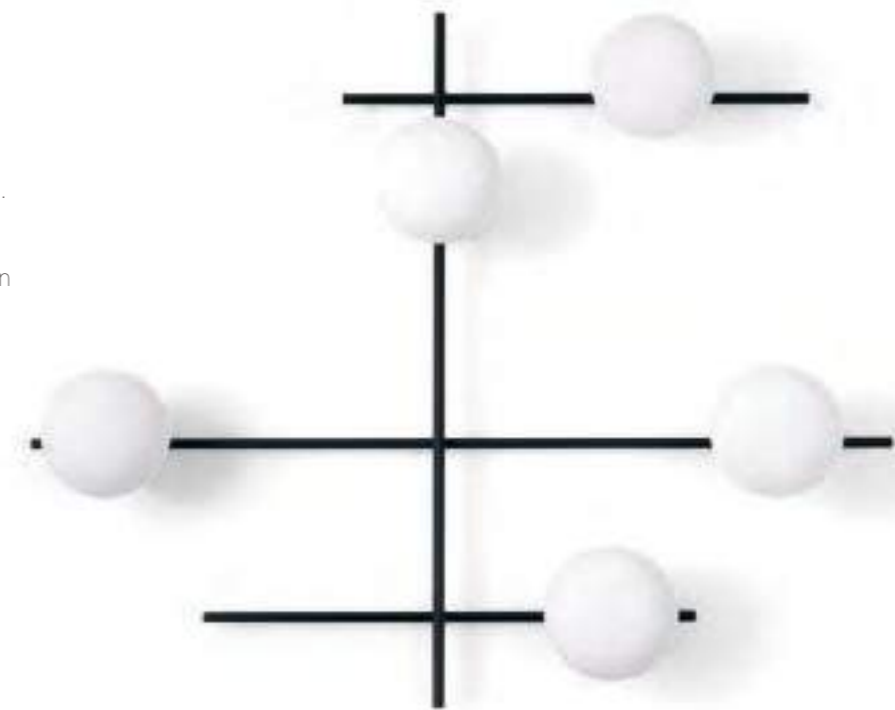

# MIKADO

WINNER



1744.178

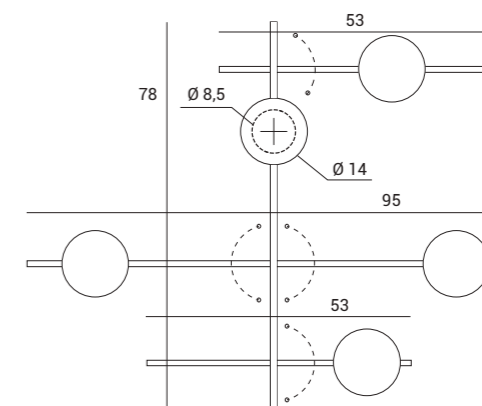

+ Uscita cavo elettrico  
+ Power Supply  
+ Brennstelle



Source

G9

Power

5 x max 28w







Lampada da tavolo. Montatura in metallo verniciato nero soft touch. Diffusore in vetro soffiato bianco latte diametro 14 cm. Lampada dotata di dimmer.

Table lamp with black soft touch powder coated metal frame. Milky white blown glass diffuser, diameter 14 cm. Equipped with dimmer.

Tischlampe mit schwarzem, pulverbeschichtetem Metallrahmen in Softtouch-Ausführung. Diffuser aus milchig-weiß geblasenem Glas, Durchmesser 14 cm. Lampe mit Dimmer ausgestattet.



# MIKADO

WINNER



1744.179

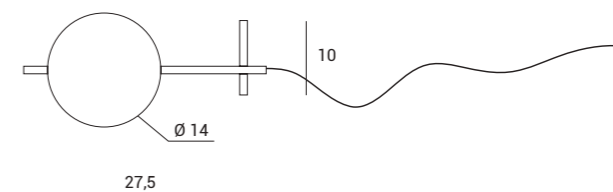

Source

G9

Dimmer

Power

1 x max 28w



Lampada da parete o soffitto con montatura in metallo verniciato a polvere nero soft touch. Diffusore in vetro borosilicato trasparente esterno e satinato interno, diametro 12 cm. La rotazione del braccio secondario consente di scegliere la posizione preferita.

Wall or ceiling lamp with black soft touch powder coated metal frame. Diffuser in transparent borosilicate glass outside and satin inside, diameter 12 cm. The rotation of the secondary arm allows to choose the preferred position.

Wand- oder Deckenleuchte mit schwarzem, pulverbeschichtetem Metallrahmen in Softtouch-Ausführung. Diffuser aus Borosilikatglas, das außen transparent und innen satiniert ist, Durchmesser 12 cm. Durch ein Drehen des sekundären Arms kann man die Leuchte in die gewünschte Stellung bringen.



## MIKADO

1744.218

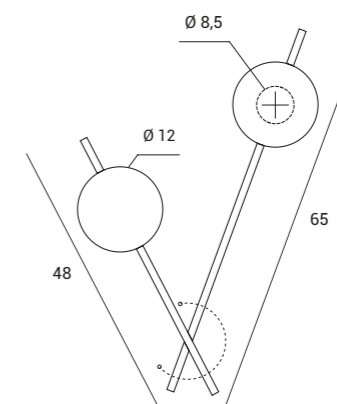

+ Uscita cavo elettrico  
+ Power Supply  
+ Brennstelle



Source

G9

Power

2 x max 28w



### ESEMPI DI POSSIBILI CONFIGURAZIONI / EXAMPLES OF POSSIBLE CONFIGURATIONS / GESTALTUNGSMÖGLICHKEITEN

La rotazione del braccio secondario consente di scegliere la posizione preferita.  
The rotation of the secondary arm allows to choose the preferred position.  
Die Gestellarme ermöglichen das Einstellen der optimalen Leuchtposition.

- + Uscita cavo elettrico
- + Power Supply
- + Brennstelle

CONFIGURAZIONE  
2 LUCI

2 LIGHTS  
CONFIGURATION

EINSTELLEN VON  
2 LEUCHTEN

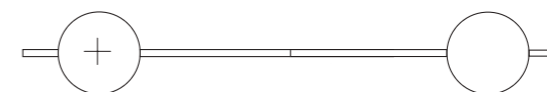

CONFIGURAZIONE  
2 LUCI

2 LIGHTS  
CONFIGURATION

EINSTELLEN VON  
2 LEUCHTEN

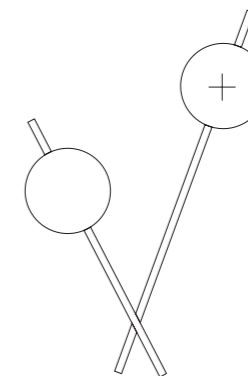

CONFIGURAZIONE  
2 LUCI

2 LIGHTS  
CONFIGURATION

EINSTELLEN VON  
2 LEUCHTEN

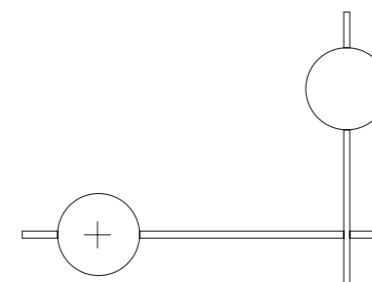

# MIKADO

1744.218

WINNER



...E MOLTO ALTRO  
...AND MANY MORE  
...UND VIELE WEITERE MÖGLICHKEITEN



Lampada a parete o soffitto con montatura in metallo verniciato a polvere nero soft touch. Diffusore in vetro borosilicato trasparente esterno e satinato interno, diametro 12 cm. La rotazione del braccio secondario consente di scegliere la posizione preferita.

Wall or ceiling lamp with black soft touch powder coated metal frame. Diffuser in transparent borosilicate glass outside and satin inside, diameter 12 cm. The rotation of the secondary arm allows to choose the preferred position.

Wand- oder Deckenleuchte mit schwarzem, pulverbeschichtetem Metallrahmen in Softtouch-Ausführung. Diffuser aus Borosilikatglas, das außen transparent und innen satiniert ist, Durchmesser 12 cm. Durch ein Drehen des sekundären Arms kann man die Leuchte in die gewünschte Stellung bringen.

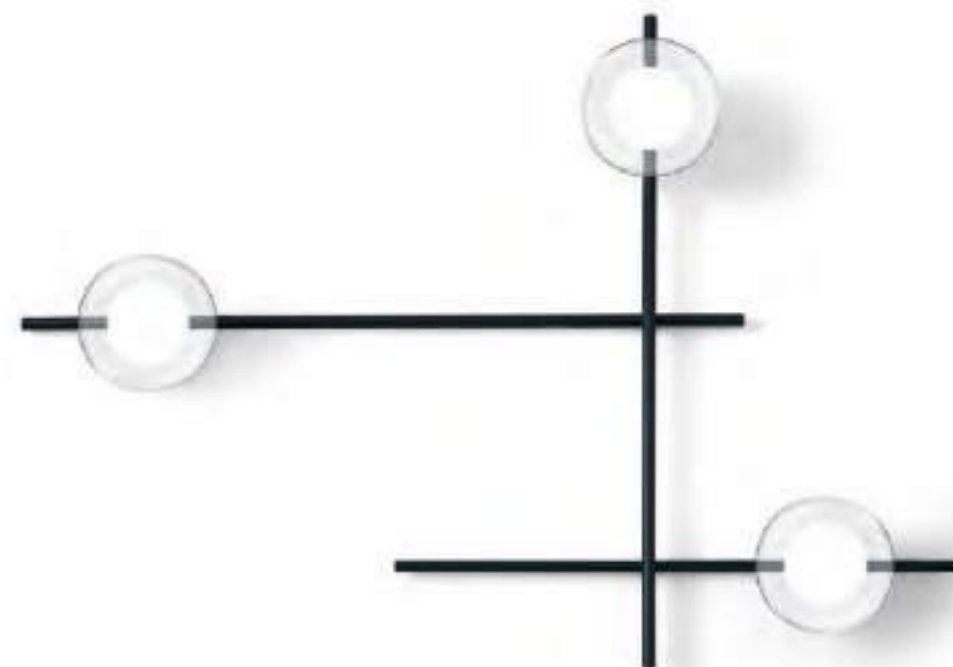

# MIKADO

1744.219

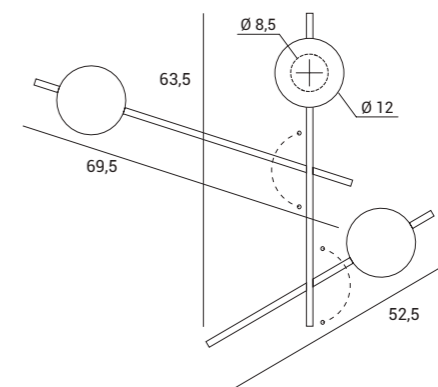

+ Uscita cavo elettrico  
+ Power Supply  
+ Brennstelle



Source

G9

Power

3 x max 28w

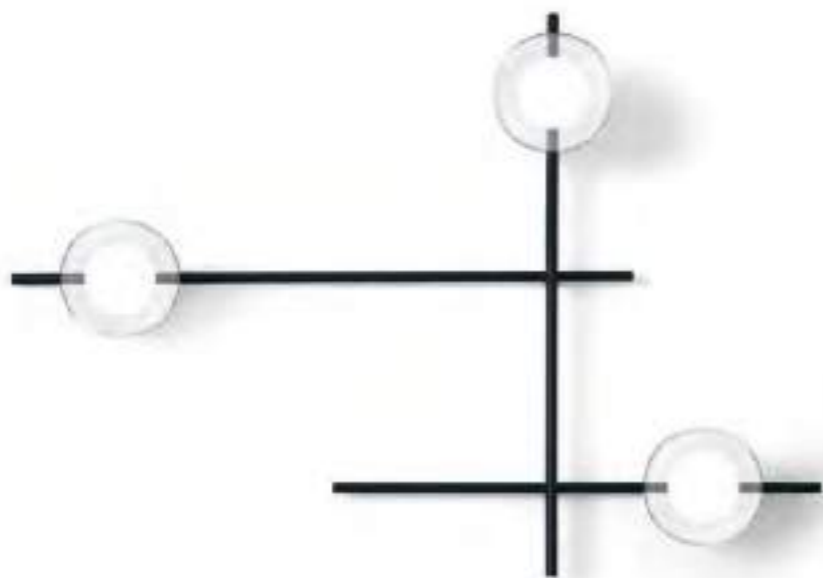

### ESEMPI DI POSSIBILI CONFIGURAZIONI / EXAMPLES OF POSSIBLE CONFIGURATIONS / GESTALTUNGSMÖGLICHKEITEN

La rotazione dei bracci secondari consente di scegliere la posizione preferita.  
The rotation of the secondary arms allows to choose the preferred position.  
Die Gestellarme ermöglichen das Einstellen der optimalen Leuchtposition.

- + Uscita cavo elettrico
- + Power Supply
- + Brennstelle

CONFIGURAZIONE  
3 LUCI

3 LIGHTS  
CONFIGURATION

EINSTELLEN VON  
3 LEUCHTEN

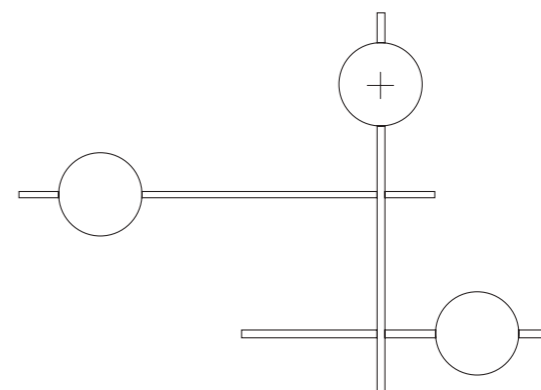

CONFIGURAZIONE  
3 LUCI

3 LIGHTS  
CONFIGURATION

EINSTELLEN VON  
3 LEUCHTEN

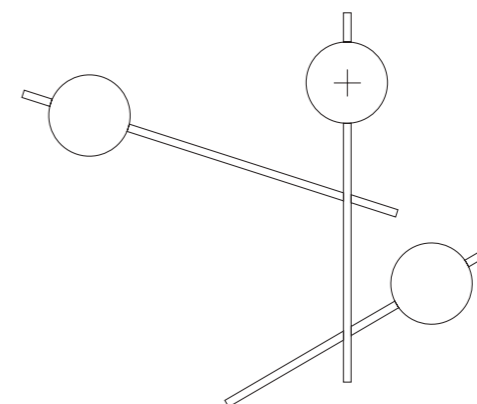

# MIKADO

1744.219

WINNER



...E MOLTO ALTRO  
...AND MANY MORE  
...UND VIELE WEITERE MÖGLICHKEITEN









Lampada a parete o soffitto con montatura in metallo verniciato a polvere nero soft touch. La rotazione dei bracci secondari consente di scegliere la posizione preferita.

Wall or ceiling lamp with black soft touch powder coated metal frame. Diffuser in transparent borosilicate glass outside and satin inside, diameter 12 cm. The rotation of the secondary arms allows to choose the preferred position.

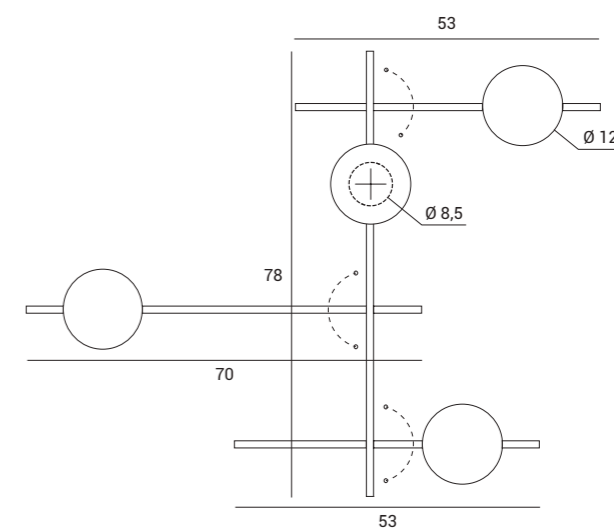
Wand- oder Deckenleuchte mit schwarzem, pulverbeschichtetem Metallrahmen in Softtouch-Ausführung. Diffuser aus Borosilikatglas, das außen transparent und innen satiniert ist, Durchmesser 12 cm. Durch ein Drehen des sekundären Arms kann man die Leuchte in die gewünschte Stellung bringen.



+ Uscita cavo elettrico  
+ Power Supply  
+ Brennstelle

  
Source  
G9

Power  
4 x max 28w

# MIKADO

1744.220



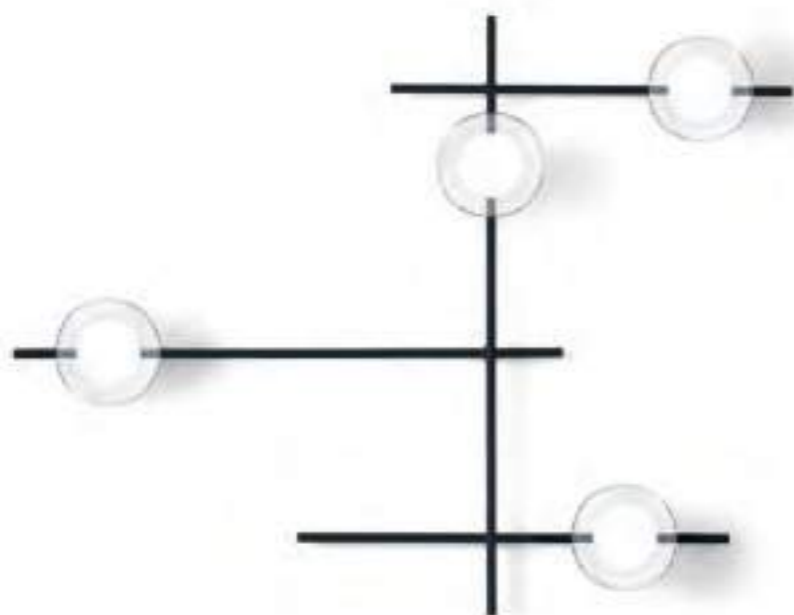

# MIKADO

1744.220

WINNER



## ESEMPI DI POSSIBILI CONFIGURAZIONI / EXAMPLES OF POSSIBLE CONFIGURATIONS / GESTALTUNGSMÖGLICHKEITEN

La rotazione dei bracci secondari consente di scegliere la posizione preferita.  
The rotation of the secondary arms allows to choose the preferred position.  
Die Gestellarme ermöglichen das Einstellen der optimalen Leuchtposition.

- + Uscita cavo elettrico
- + Power Supply
- + Brennstelle

CONFIGURAZIONE  
4 LUCI

4 LIGHTS  
CONFIGURATION

EINSTELLEN VON  
4 LEUCHTEN

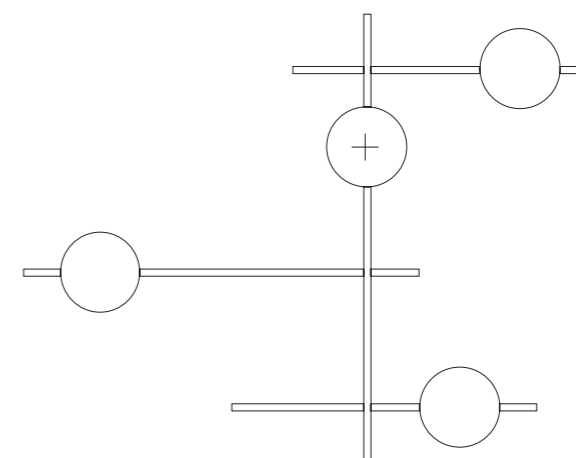

CONFIGURAZIONE  
4 LUCI

4 LIGHTS  
CONFIGURATION

EINSTELLEN VON  
4 LEUCHTEN

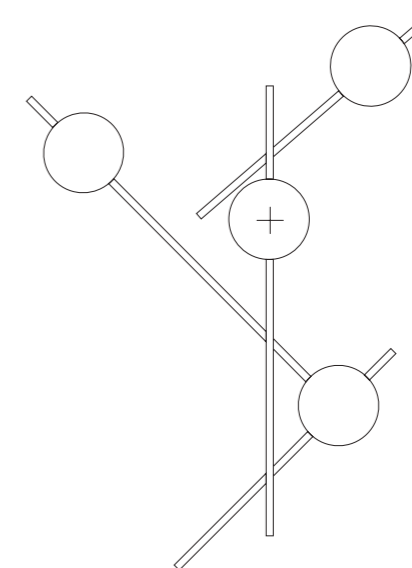

...E MOLTO ALTRO  
...AND MANY MORE  
...UND VIELE WEITERE MÖGLICHKEITEN

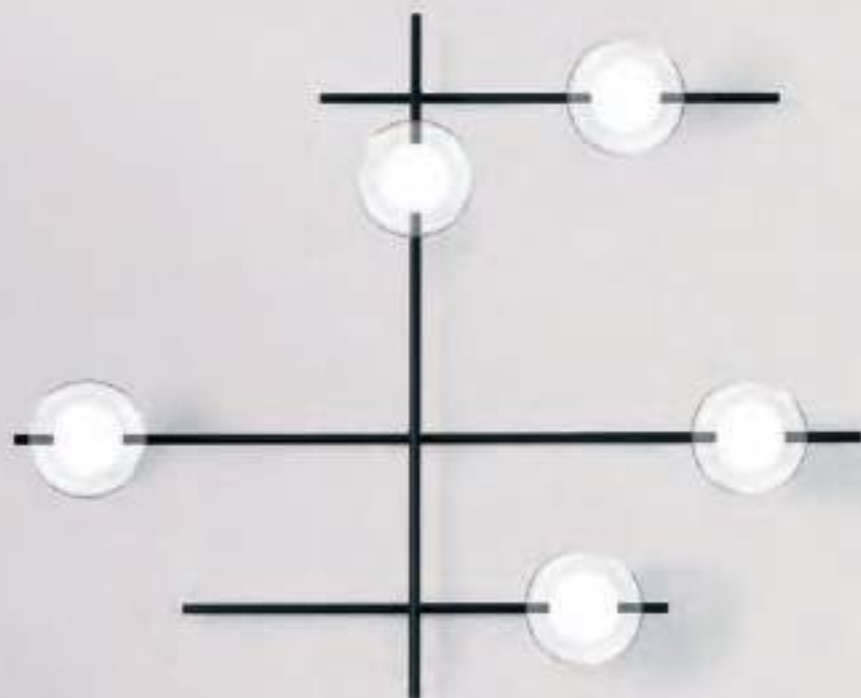

Lampada a parete o soffitto.  
Montatura in metallo verniciato a polvere nero soft touch.  
Diffusore in vetro borosilicato trasparente esterno e satinato interno, diametro 12 cm.  
La rotazione dei bracci secondari consente di scegliere la posizione preferita.

Wall or ceiling lamp with black soft touch powder coated metal frame. Diffuser in transparent borosilicate glass outside and satin inside, diameter 12 cm.  
The rotation of the secondary arm allows to choose the preferred position.

Wand- oder Deckenleuchte mit schwarzem, pulverbeschichtetem Metallrahmen in Softtouch-Ausführung.  
Diffuser aus Borosilikatglas, das außen transparent und innen satiniert ist, Durchmesser 12 cm.  
Durch ein Drehen des sekundären Arms kann man die Leuchte in die gewünschte Stellung bringen.

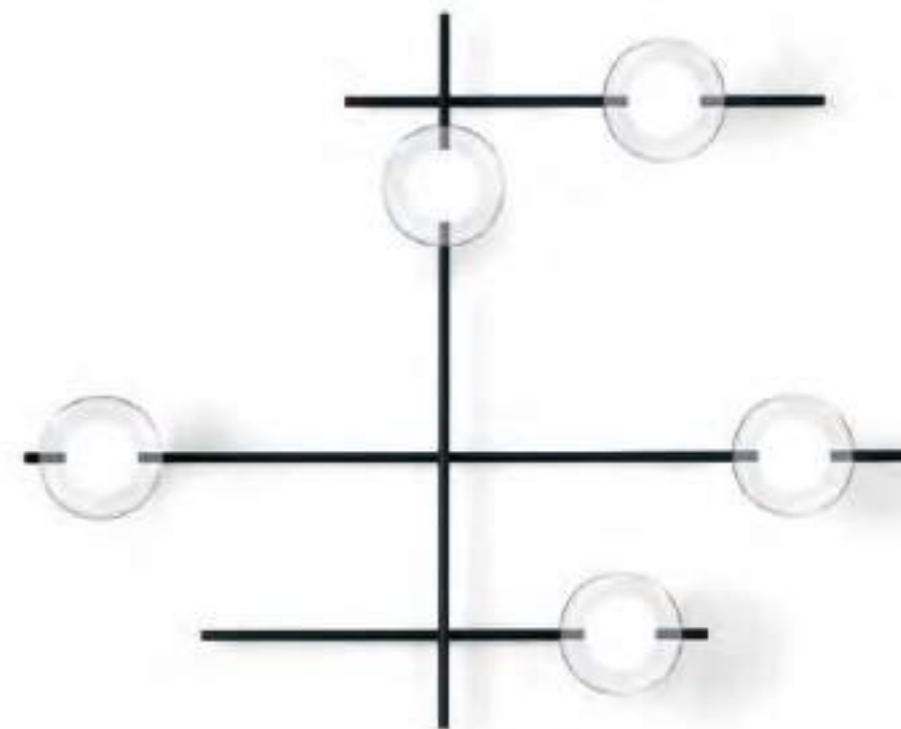

# MIKADO

WINNER



1744.221

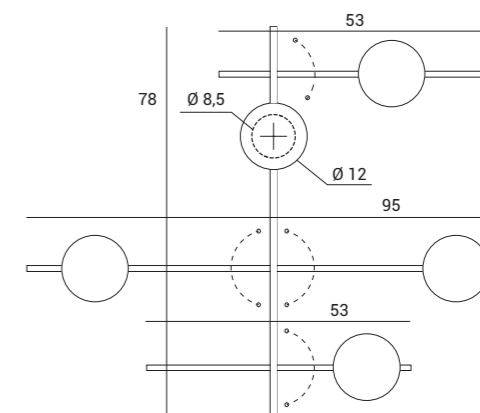

+ Uscita cavo elettrico  
+ Power Supply  
+ Brennstelle



Source

G9

Power

5 x max 28w

Lampada da tavolo.  
Montatura in metallo  
verniciato nero soft touch.  
Diffusore in vetro borosilicato  
trasparente esterno e satinato  
interno, diametro 12 cm.  
Lampada dotata di dimmer.

Table lamp with black soft  
touch powder coated metal  
frame. Diffuser in transparent  
borosilicate glass outside and  
satin inside, diameter 12 cm.  
Equipped with dimmer.

Wand- oder Deckenleuchte  
mit schwarzem,  
pulverbeschichtetem  
Metallrahmen in  
Softtouch-Ausführung.  
Diffuser aus Borosilikatglas,  
das außen transparent  
und innen satiniert ist,  
Durchmesser 12 cm.  
Lampe mit Dimmer  
ausgestattet



# MIKADO

WINNER



1744.222

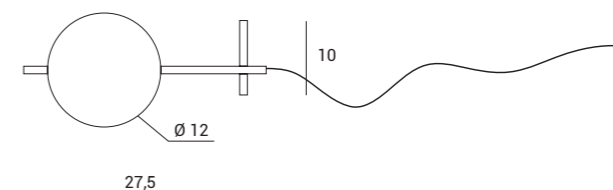

Source

G9

Dimmer

Power

1 x max 28w



Lampada da tavolo in vetro soffiato bianco latte. Montatura in metallo verniciato nero soft-touch, con particolari in ottone spazzolato, rame spazzolato, bronzo spazzolato. Lampada dotata di dimmer.

Table lamp In milk white blown glass. Black soft-touch painted metal frame, with details in brushed brass, brushed copper, brushed bronze. Dimmable lamp.

Tischleuchte mit Kugelglas aus geblasenem Glas in Milchweiß. Standfuß aus Metall lackiert mit schwarzem Soft-Touch-Lack. Details aus gebürstetem Messing, Kupfer und Bronze. Ausgestattet mit Dimmer.



# MOSE

1744.196

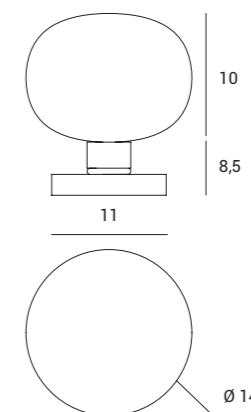

Source

G9

Dimmer

Power

max 40w

Lampada da parete o soffitto in vetro soffiato bianco latte. Montatura in metallo verniciato nero soft-touch, con particolari in ottone spazzolato, rame spazzolato, bronzo spazzolato.

Wall and ceiling lamp In milk white blown glass. Black soft-touch painted metal frame, with details in brushed brass, brushed copper, brushed bronze.

Wand- und Deckenleuchte mit Kugelglas aus geblasenem Glas in Milchweiß, Halterung aus Metall, lackiert mit schwarzem Soft-Touch-Lack, Details aus gebürstetem Messing, Kupfer und Bronze.



## MOSE

1744.197

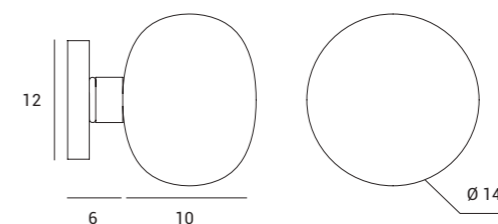

Source

G9

Power

max 40w



Lampada da parete o soffitto in vetro soffiato bianco latte. Montatura in metallo verniciato nero soft-touch, con particolari in ottone spazzolato, rame spazzolato, bronzo spazzolato.

Wall and ceiling lamp In milk white blown glass. Black soft-touch painted metal frame, with details in brushed brass, brushed copper, brushed bronze.

Wand- und Deckenleuchte mit Kugelglas aus geblasenem Glas in Milchweiß. Halterung aus Metall lackiert mit schwarzem Soft-Touch-Lack, Details aus gebürstetem Messing, Kupfer und Bronze.



# MOSE

1744.197

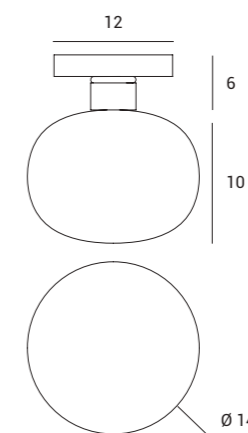

Source

G9

Power

max 40w

Lampada a sospensione in vetro soffiato bianco latte. Montatura in metallo verniciato nero soft-touch, con particolari in ottone spazzolato, rame spazzolato e bronzo spazzolato.

Pendant lamp in milk white blown glass. Black soft-touch painted metal frame, with details in brushed brass, brushed copper and brushed bronze.

Pendelleuchte aus geblasenem Glas in Milchweiß. Fassungsstruktur aus Metall lackiert mit schwarzem Soft-Touch-Lack, Details aus gebürstetem Messing, Kupfer und Bronze.

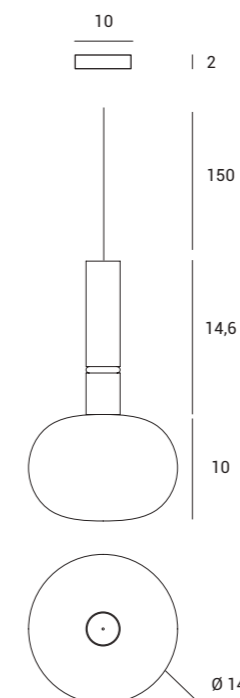

# MOSE



Source

G9

Power

max 40w

per configurazione del sistema vedere pagina 75/ for system configuration view page 75/  
Systemkonfiguration siehe Seite 75







Lampada a sospensione in vetro soffiato bianco latte. Montatura in metallo verniciato nero soft-touch, con particolari in ottone spazzolato, rame spazzolato e bronzo spazzolato.

Pendant lamp in milk white blown glass. Black soft-touch painted metal frame, with details in brushed brass, brushed copper and brushed bronze.

Pendelleuchte aus geblasenem Glas in Milchweiß. Fassungsstruktur aus Metall lackiert mit schwarzem Soft-Touch-Lack, Details aus gebürstetem Messing, Kupfer und Bronze.



# MOSE

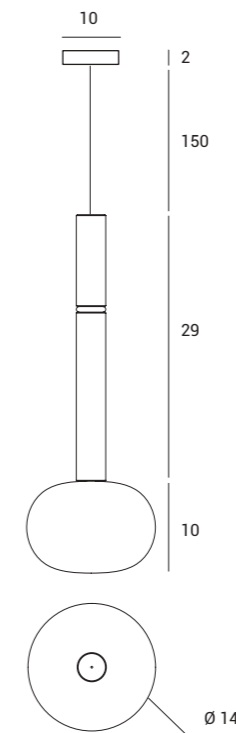

Source

G9

Power

max 40w

per configurazione del sistema vedere pagina 75/ for system configuration view page 75/  
Systemkonfiguration siehe Seite 75







Lampada a sospensione in vetro soffiato bianco latte. Montatura in metallo verniciato nero soft-touch, con particolari in ottone spazzolato, rame spazzolato e bronzo spazzolato.

Pendant lamp in milk white blown glass. Black soft-touch painted metal frame, with details in brushed brass, brushed copper brushed bronze.

Pendelleuchte aus geblasenem Glas in Milchweiß. Fassungsstruktur aus Metall lackiert mit schwarzem Soft-Touch-Lack, Details aus gebürstetem Messing, Kupfer und Bronze.



# MOSE

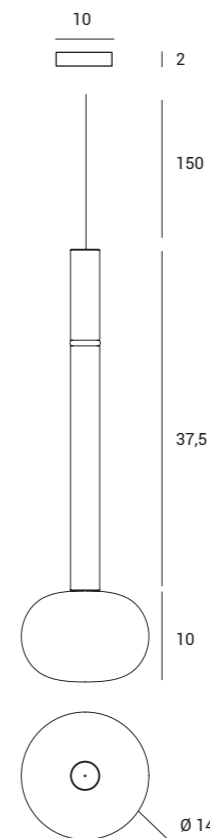

Source

G9

Power

max 40w









Lampada a sospensione in vetro soffiato bianco latte. Montatura in metallo verniciato nero soft-touch, con particolari in ottone spazzolato rame, spazzolato e bronzo spazzolato.

Pendant lamp in milk white blown glass. Black soft-touch painted metal frame, with details in brushed brass, copper brushed and brushed bronze.

Pendelleuchte aus geblasenem Glas in Milchweiß. Fassungsstruktur aus Metall lackiert mit schwarzem Soft-Touch-Lack, Details aus gebürstetem Messing, Kupfer und Bronze.

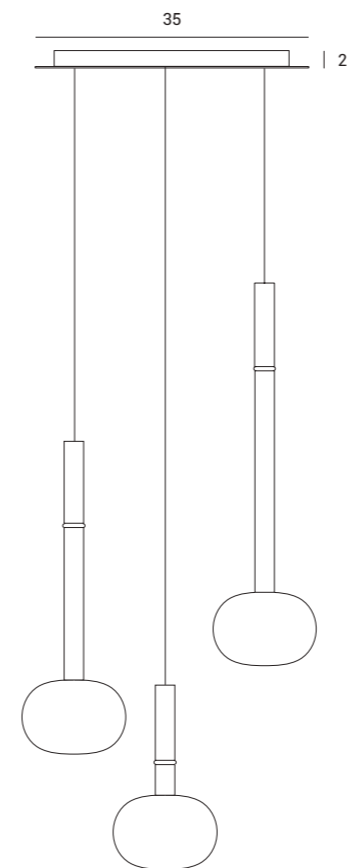

# MOSE

per configurazione del sistema vedere pagina 75/ for system configuration view page 75/  
Systemkonfiguration siehe Seite 75



Source

G9

Power

3x max 40w





Lampada a sospensione in vetro soffiato bianco latte. Montatura in metallo verniciato nero soft-touch, con particolari in ottone spazzolato rame spazzolato e bronzo spazzolato.

Pendant lamp in milk white blown glass. Black soft-touch painted metal frame, with details in brushed brass, brushed copper and brushed bronze.

Pendelleuchte aus geblasenem Glas in Milchweiß. Fassungsstruktur aus Metall lackiert mit schwarzem Soft-Touch-Lack, Details aus gebürstetem Messing Kupfer und Bronze.

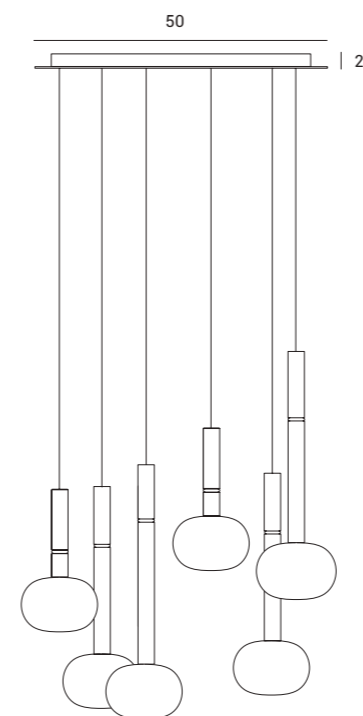

# MOSE

per configurazione del sistema vedere pagina 75/ for system configuration view page 75/  
Systemkonfiguration siehe Seite 75



Source

G9

Power

6x max 40w



Lampada a sospensione in vetro soffiato bianco latte. Montatura in metallo verniciato nero soft-touch, con particolari in ottone spazzolato e bronzo spazzolato.

Pendant lamp in milk white blown glass. Black soft-touch painted metal frame, with details in brushed brass, brushed copper and brushed bronze.

Pendelleuchte aus geblasenem Glas in Milchweiß. Fassungsstruktur aus Metall lackiert mit schwarzem Soft-Touch-Lack, Details aus gebürstetem Messing Kupfer und Bronze.

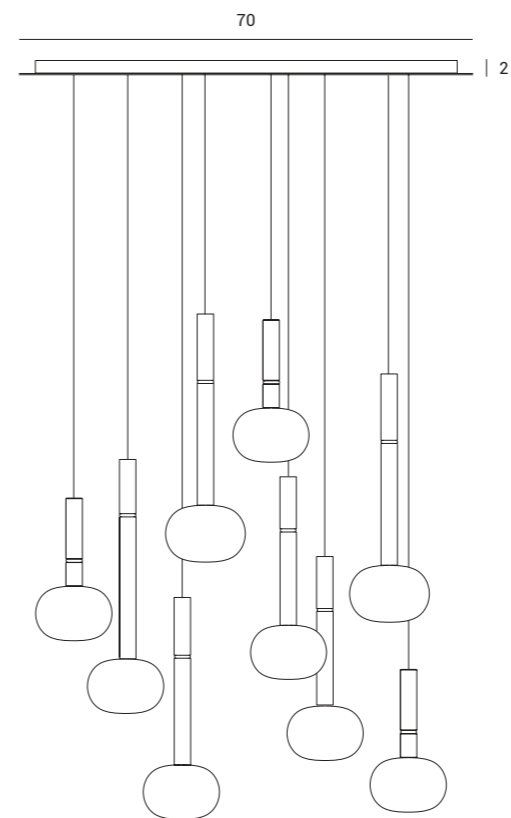

# MOSE

per configurazione del sistema vedere pagina 75/ for system configuration view page 75/  
Systemkonfiguration siehe Seite 75



Source

G9

Power

9x max 40w



# MOSE

KIT PER SOSPENSIONI  
KIT FOR PENDANT LIGHT  
PENDELLEUCHTEN-BAUSATZ

KIT per configurazione personalizzata  
serie di lampade a sospensione Mose a 1, 3, 6 e 9 luci.  
Possibilità di configurare la sospensione con lampade di diversi colori e altezze.

Kit for custom configuration  
Series of Mose pendant lamps with 1, 3, 6 and 9 lights.  
Possibility to configure the pendant with lamps of different colours and heights.

BAUSATZ für kundenspezifische Gestaltung.  
Pendelleuchterserie Mose mit 1, 3, 6 und 9 Leuchten.  
Möglichkeit, die Leuchten in verschiedenen Farben und Höhen zu kombinieren.

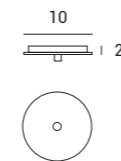

## 1744.M.183

Rosone per sospensioni a 1 luce  
Canopie for pendant light with 1 light  
Rosette für 1 Lampenpendel  
diametro/diameter/ Durchmesser cm 10  
altezza/height/ cm 2.

FORMA/SHAPE/BILDEN

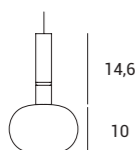

ORO SPAZZOLATO  
BRUSHED GOLD  
GEBÜRSTETES GOLD

1744.187



BRONZO SPAZZOLATO  
BRUSHED BRONZE  
GEBÜRSTETES BRONZE

1744.188



RAME SPAZZOLATO  
BRUSHED COPPER  
GEBÜRSTETES KUPFER

1744.189

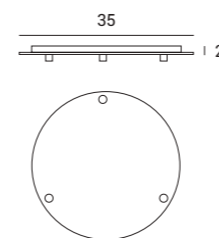

## 1744.M.184

Rosone per sospensioni a 3 luci  
Canopie for pendant light with 3 light  
Rosette für 3 Lampenpendel  
diametro/diameter/Durchmesser cm 35  
altezza/height/ Höhe cm 2.

FORMA/SHAPE/BILDEN

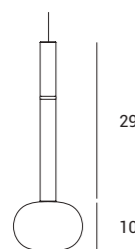

1744.190



1744.191



1744.192

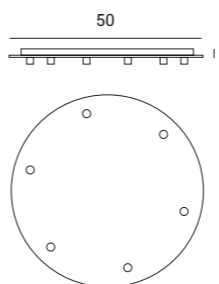

## 1744.M.185

Rosone per sospensioni a 6 luci  
Canopie for pendant light with 6 light  
Rosette für 6 Lampenpendel  
diametro/diameter/Durchmesser  
cm 50 altezza/height/Höhe cm 2.

FORMA/SHAPE/BILDEN

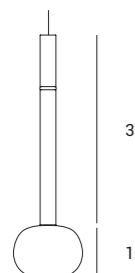

1744.193



1744.194



1744.195

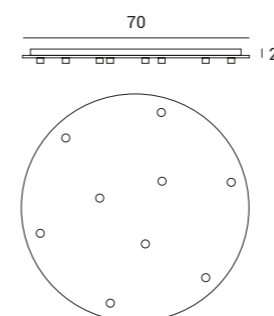

## 1744.M.186

Rosone per sospensioni a 9 luci  
Canopie for pendant light with 9 light  
Rosette für 9 Lampenpendel  
diametro/diameter/Durchmesser cm 70  
altezza/height/Höhe cm 2.



Lampada a sospensione in metallo verniciato grigio perla. Diffusore in vetro sabbato. Cavo di alimentazione 120 cm.

Suspension lamp in pearl gray painted metal with sandblasted glass diffuser. Power cable 120 cm.

Pendelleuchte mit doppeltem Leuchtschirm aus grauem Metall und sandgestrahltem Glas. Kabellänge 120 cm.



# BABELE

1744.174

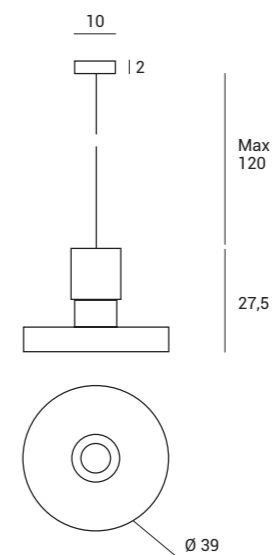

Source

E27

Power

1 x max 40w





Lampada a sospensione con diffusore interno in vetro sabbato. Metallo esterno grigio cenere, cupola in grigio scuro, tubetto cavo di alimentazione e rosone nero opaco.

Suspension lamp with internal diffuser in sandblasted glass. Ash gray external metal, dark gray dome, power cable and matt black canopy.

Pendelleuchte mit Leuchtschirm. Innen sandgestrahltes Glas, außen aschgraue Metallfarbe mit Abdeckung des Leuchtschirms in dunkelgrauer Farbe. Kabelrohr, Netzkabel und Baldachin in mattem Schwarz.



# ALBA

1744.209

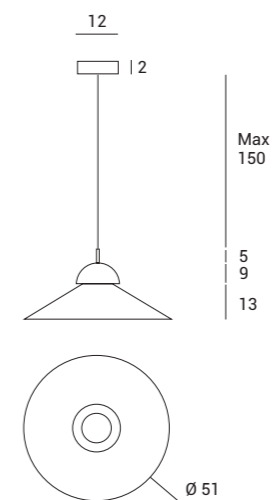

Source

E27

Power

1 x max 40w





Lampada a parete o a soffitto.  
Montatura in metallo verniciato  
grigio perla. Diffusore in vetro  
soffiato bianco latte diametro  
14 cm.

Wall or ceiling lamp. Pearl grey  
painted metal frame. Milky  
white blown glass diffuser  
diameter 14 cm.

Wand- oder Deckenleuchte.  
Halterung aus Metall,  
pulverbeschichtet in Grau.  
Kugelglas aus geblasenem  
Glas in Milchweiß,  
Durchmesser 14 cm.



# POT

1744.180

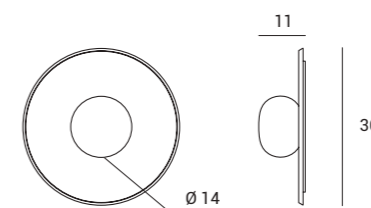

Source

G9

Power

1 x max 28w



Lampada a parete o a soffitto.  
Montatura in metallo verniciato  
grigio perla. Diffusore in vetro  
soffiato bianco latte diametro  
14 cm.

Wall or ceiling lamp. Pearl grey  
painted metal frame. Milky white  
blown glass diffuser diameter  
14 cm.

Wand- oder Deckenleuchte.  
Halterung aus Metall,  
pulverbeschichtet in Grau.  
Kugelglas aus geblasenem  
Glas in Milchweiß, Durchmesser  
14 cm.



# POT

1744.180

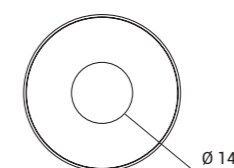
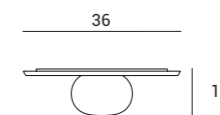

Source

G9

Power

1 x max 28w





Lampada a parete o a soffitto.  
Montatura in metallo verniciato  
a polvere grigio perla. Diffusori  
in vetro soffiato bianco latte  
diametro 14 cm.

Wall or ceiling lamp. Pearl grey  
powder coated metal frame.  
Milky white blown glass  
diffusers diameter 14 cm.

Wand- oder Deckenleuchte.  
Halterung aus Metall,  
pulverbeschichtet in Grau.  
Kugelgläser aus geblasenem  
Glas in Milchweiß, Durchmesser  
14 cm.



# POT

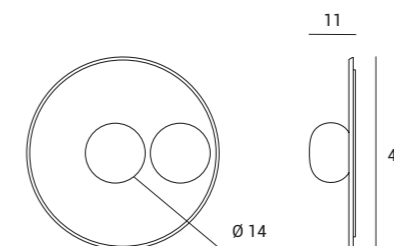

1744.181



Source

G9

Power

2 x max 28w





Lampada a parete o a soffitto.  
Montatura in metallo verniciato  
a polvere grigio perla. Diffusori  
in vetro soffiato bianco latte  
diametro 14 cm.

Wall or ceiling lamp. Pearl grey  
powder coated metal frame.  
Milky white blown glass  
diffusers diameter 14 cm.

Wand- oder Deckenleuchte.  
Halterung aus Metall,  
pulverbeschichtet in Grau.  
Kugelgläser aus geblasenem  
Glas in Milchweiß,  
Durchmesser 14 cm.



# POT

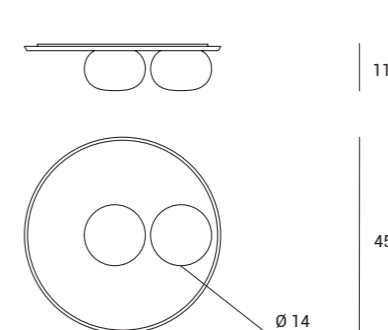

1744.181



Source

G9

Power

2 x max 28w



Lampada a parete o a soffitto.  
Montatura in metallo verniciato  
a polvere grigio perla. Diffusori in  
vetro soffiato bianco latte  
diametro 14 cm.

Wall or ceiling lamp. Pearl grey  
powder coated metal frame.  
Milky white blown glass  
diffusers diameter 14 cm.

Wand- oder Deckenleuchte.  
Halterung aus Metall,  
pulverbeschichtet in Grau.  
Kugelgläser aus geblasenem  
Glas in Milchweiß, Durchmesser  
14 cm.



# POT

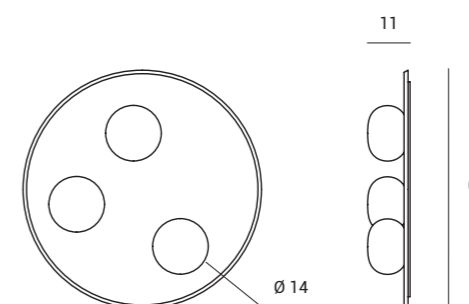

1744.182



Source

G9

Power

3 x max 28w



Lampada a parete o a soffitto.  
Montatura in metallo verniciato  
a polvere grigio perla. Diffusori  
in vetro soffiato bianco latte  
diametro 14 cm.

Wall or ceiling lamp. Pearl grey  
powder coated metal frame.  
Milky white blown glass  
diffusers diameter 14 cm.

Wand- oder Deckenleuchte.  
Halterung aus Metall,  
pulverbeschichtet in Grau.  
Kugelgläser aus geblasenem  
Glas in Milchweiß, Durchmesser  
14 cm.



POT

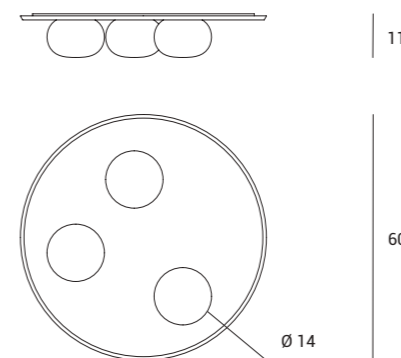

1744.182



Source

G9

Power

3 x max 28w



Lampada a parete con montatura in metallo verniciato a polvere nero soft touch. Diffusore in vetro soffiato bianco latte di diametro 17.5 cm.

Gli snodi in ottone consentono di alzare o abbassare la lampada secondo le proprie preferenze.

Wall lamp with black soft touch powder coated metal frame. Milky white blown glass diffuser measuring 17,5 in diameter.

Brass joints can be used to raise or lower the lamp according to personal preference.

Wandleuchte mit schwarzem, Soft-Touch-pulverbeschichtetem Metallgestell und milchig-weißem, aus Glas geblasenen Leuchtschirm mit einem Durchmesser von 17,5 cm.

Die Messingelenke ermöglichen Ihnen, die Leuchte nach Ihrem Wunsch zu heben oder zu senken.

## NEO RETRO

1744.213

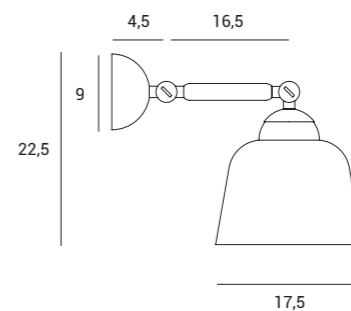

Source

E27

Power

1 x max 40w





Lampada a soffitto con montatura in metallo verniciato a polvere nero soft touch. Diffusore in vetro soffiato bianco latte di diametro 17.5 cm.

Gli snodi in ottone consentono di alzare o abbassare la lampada secondo le proprie preferenze.

Ceiling lamp with black soft touch powder coated metal frame. Milky white blown glass diffuser measuring 17,5 in diameter.

Brass joints can be used to raise or lower the lamp according to personal preference

Deckenlampe mit schwarzem, Soft-Touch-pulverbeschichtetem Metallgestell und milchig-weißem, aus Glas geblasenen Leuchtschirm mit einem Durchmesser von 17,5 cm.

Die Messinggelenke ermöglichen Ihnen, die Leuchte nach Ihrem Wunsch zu heben oder zu senken.



## NEO RETRO

1744.213

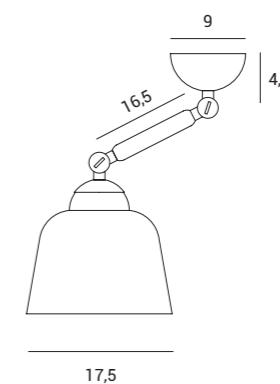

Source

E27

Power

1 x max 40w





Lampada a parete con montatura in metallo verniciato a polvere nero soft touch. Diffusore in vetro soffiato bianco latte di diametro 17.5 cm.

Gli snodi in ottone consentono di alzare o abbassare la lampada secondo le proprie preferenze.

Wall lamp with black soft touch powder coated metal frame. Milky white blown glass diffuser measuring 17,5 in diameter.

Brass joints can be used to raise or lower the lamp according to personal preference

Wandleuchte mit schwarzem, Soft-Touch-pulverbeschichtetem Metallgestell und milchig-weißem, aus Glas geblasenen Leuchtschirm mit einem Durchmesser von 17,5 cm.

Die Messinggelenke ermöglichen Ihnen, die Leuchte nach Ihrem Wunsch zu heben oder zu senken.



## NEO RETRO

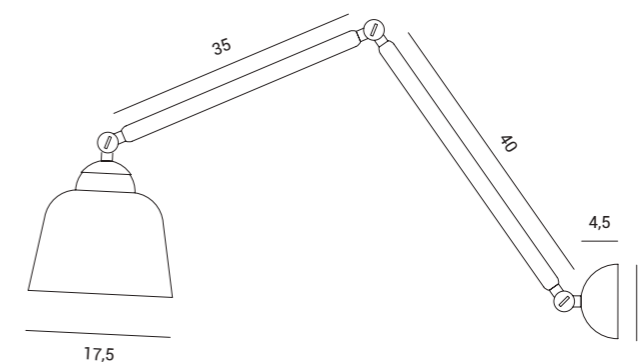

Source

E27

Power

1 x max 40w

1744.214

Lampada a soffitto con montatura in metallo verniciato a polvere nero soft touch. Diffusore in vetro soffiato bianco latte di diametro 17.5 cm.

Gli snodi in ottone consentono di alzare o abbassare la lampada secondo le proprie preferenze.

Ceiling lamp with black soft touch powder coated metal frame. Milky white blown glass diffuser measuring 17,5 in diameter.

Brass joints can be used to raise or lower the lamp according to personal preference.

Deckenlampe mit schwarzem, Soft-Touch-pulverbeschichtetem Metallgestell und milchig-weißem, aus Glas geblasenen Leuchtschirm mit einem Durchmesser von 17,5 cm.

Die Messingelenke ermöglichen Ihnen, die Leuchte nach Ihrem Wunsch zu heben oder zu senken.

## NEO RETRO

1744.214

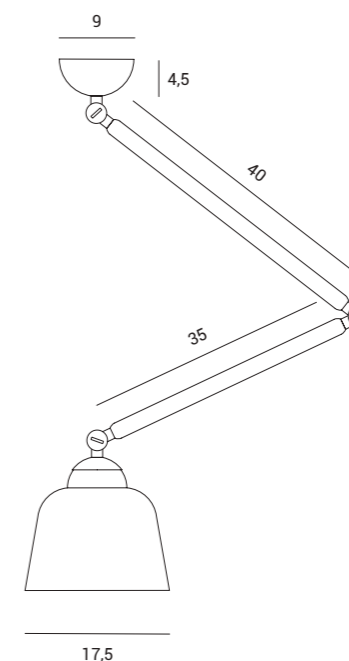

Source

E27

Power

1 x max 40w









Lampada da parete con montatura in metallo verniciato a polvere nero soft touch. Diffusore in vetro soffiato bianco latte di diametro 17.5 cm.

Gli snodi in ottone consentono di alzare o abbassare la lampada secondo le proprie preferenze.

Wall lamp with black soft touch powder coated metal frame. Milky white blown glass diffuser measuring 17,5 cm in diameter.

Brass joints can be used to raise or lower the lamp according to personal preference.

Wandleuchte mit schwarzem, Soft-Touch-pulverbeschichtetem Metallgestell und milchig-weißem, aus Glas geblasenen Leuchtschirm mit einem Durchmesser von 17,5 cm.

Die Messinggelenke ermöglichen Ihnen, die Leuchte nach Ihrem Wunsch zu heben oder zu senken.



## NEO RETRO

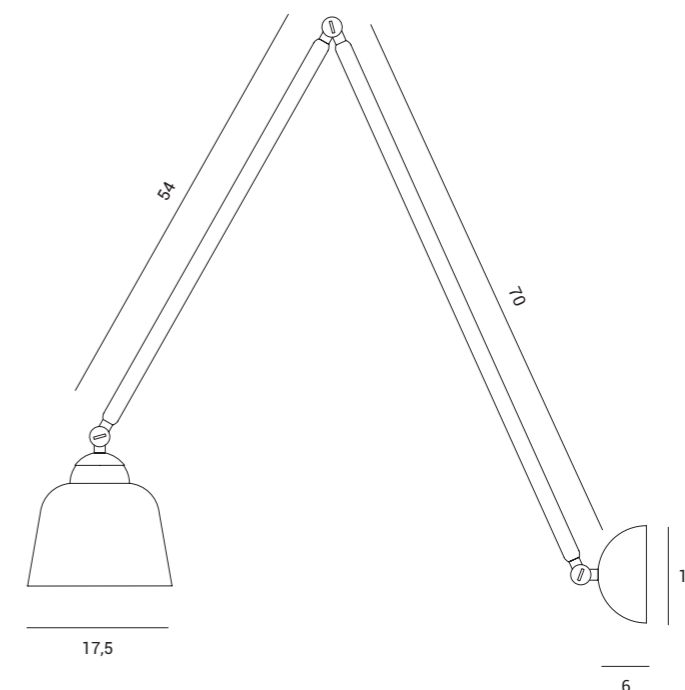

Source

E27

Power

1 x max 40w

1744.215

Lampada a soffitto con montatura in metallo verniciato a polvere nero soft touch. Diffusore in vetro soffiato bianco latte di diametro 17.5 cm.

Gli snodi in ottone consentono di alzare o abbassare la lampada secondo le proprie preferenze.

Ceiling lamp with black soft touch powder coated metal frame. Milky white blown glass diffuser measuring 17,5 in diameter.

Brass joints can be used to raise or lower the lamp according to personal preference.

Deckenlampe mit schwarzem, Soft-Touch-pulverbeschichtetem Metallgestell und milchig-weißem, aus Glas geblasenen Leuchtschirm mit einem Durchmesser von 17,5 cm.

Die Messingelenke ermöglichen Ihnen, die Leuchte nach Ihrem Wunsch zu heben oder zu senken.

## NEO RETRO

1744.215

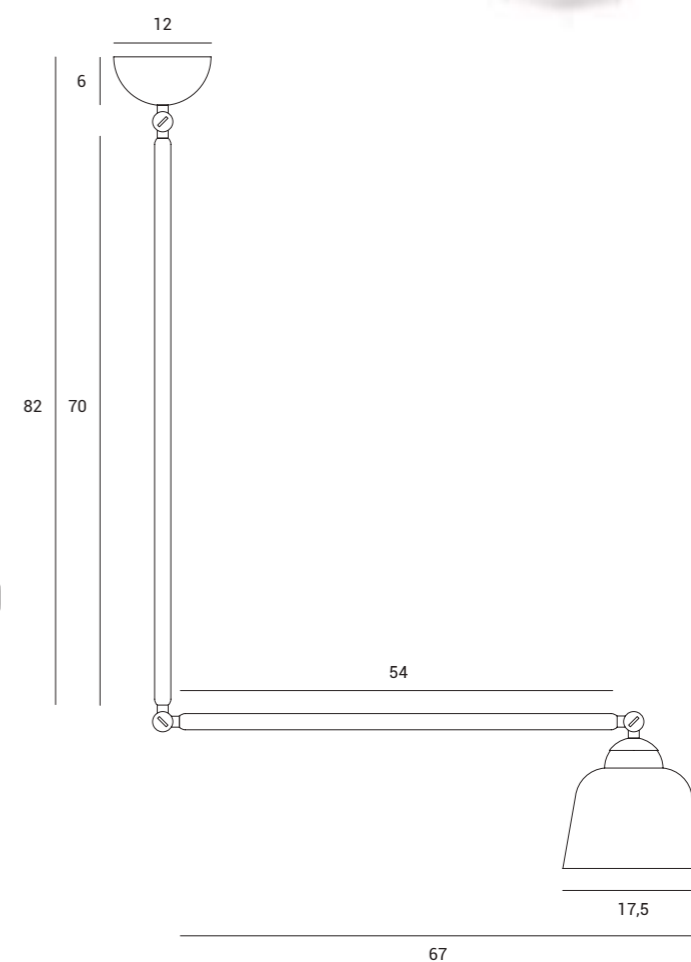

Source

E27

Power

1 x max 40w







Lampada a soffitto con montatura in metallo verniciato a polvere nero soft touch. Diffusore in vetro soffiato bianco latte di diametro 17.5 cm.

Gli snodi in ottone consentono di ruotare il punto luce.

Ceiling lamp with black soft touch powder coated metal frame. Milky white blown glass diffuser measuring 17,5 in diameter.

Brass joints can be used to turn the light point.

Deckenlampe mit Metallgestell, pulverbeschichtet mit Soft-Touch in Schwarz. Leuchtschirme in Milchweiß aus Glas geblasen, Durchmesser 17,5 cm.

Die Messinggelenke ermöglichen Ihnen die Drehen der Lichtpunkte je nach Wunsch.



## NEO RETRO

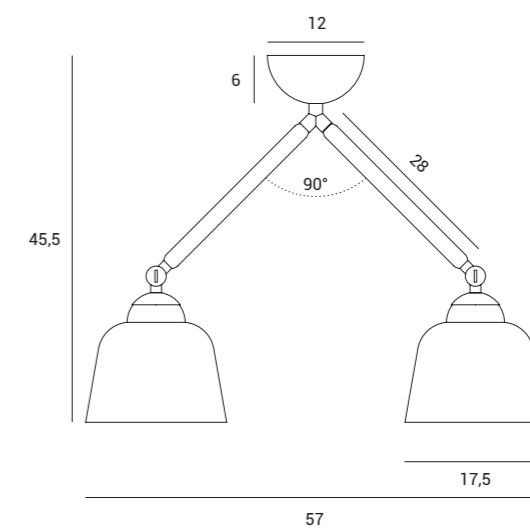

Source

E27

Power

1 x max 40w

1744.216





Lampada a soffitto con montatura in metallo verniciato a polvere nero soft touch. Diffusore in vetro soffiato bianco latte di diametro 17.5 cm.

Gli snodi in ottone consentono di ruotare il punto luce. Le aste consentono l' utilizzo a sospensione o a plafoniera.

Ceiling lamp with black soft touch powder coated metal frame. Milky white blown glass diffuser measuring 17,5 in diameter.

Brass joints can be used to turn the light point.

Deckenlampe mit schwarzem, Soft-Touch-pulverbeschichtetem Metallrahmen und milchig-weißen, aus Glas geblasenen Leuchtschirmen mit einem Durchmesser von 17,5 cm.

Die Messingelenke können zusammen mit dem Lichtpunkt gedreht werden und die beweglichen Gestellarme ermöglichen den Einsatz als Pendel- oder Deckenleuchte.

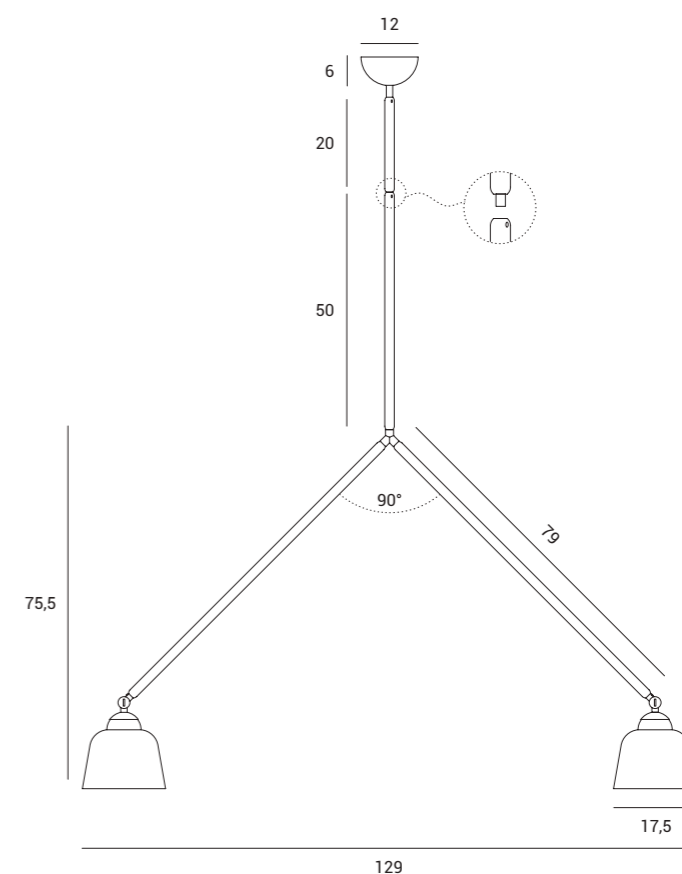

Source

E27

Power

2 x max 40w

# NEO RETRO

1744.217









Lampada a sospensione a 7 luci in vetro soffiato bianco latte diametro cm 10. Montatura verniciata nero con particolari in ottone spazzolato. Lunghezza tubo 124 cm, altezza cavi max 120 cm.

7-light pendant in milky white blown glass, measuring 10 cm in diameter. Black painted body with brushed brass details. Tube length 124 cm, max cable height 120 cm.

Pendelleuchte mit 7 Kugelgläsern aus geblasenem Glas in Milchweiß Durchmesser 10 cm. Gestell schwarz lackiert mit Details aus gebürstetem Messing. Gestellrohrlänge 124 cm, max. Stromkabelänge 120 cm.

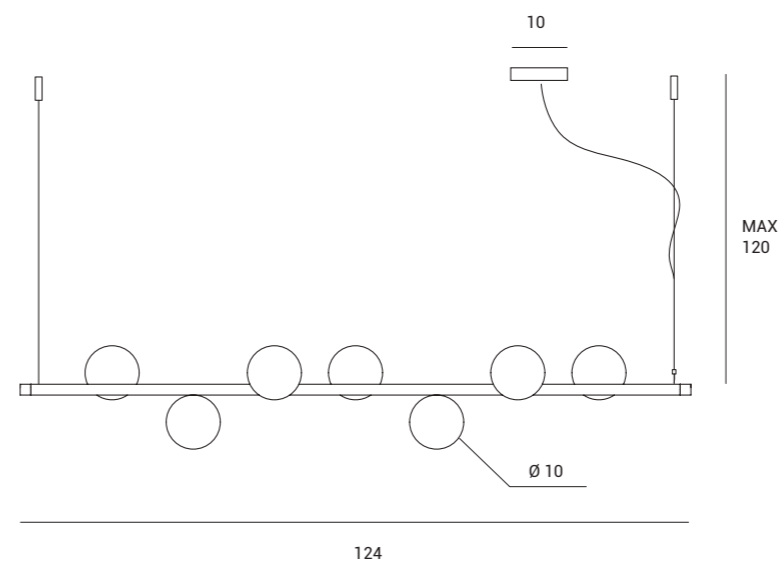
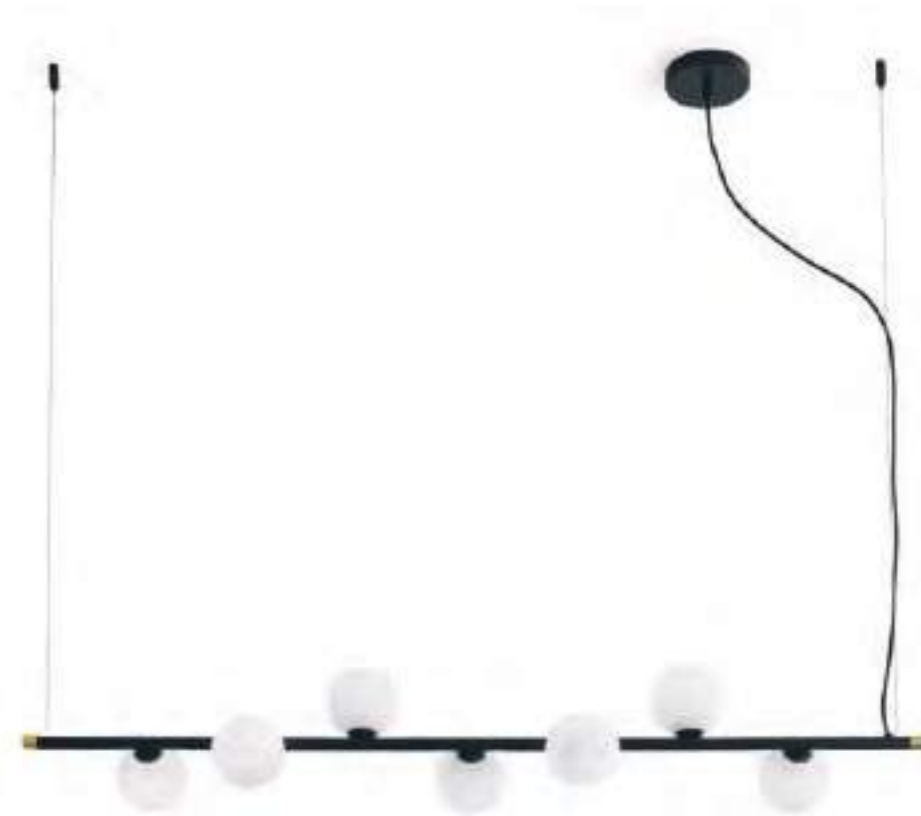

# POMÌ

1744.98



Source

G9

Power

7 x max 40w



Lampada a sospensione a  
9 luci in vetro soffiato bianco  
latte diametro cm 10. Montatura  
verniciata nero diametro 62 cm.  
Cavo di alimentazione cm 120.

9-light pendant in milky white blown  
glass, measuring 10 cm in diameter.  
Black painted body measuring 62 cm  
in diameter. Cable length 120 cm.

Pendelleuchte mit 9 Kugelgläsern  
aus geblasenem Glas in Milchweiß,  
Durchmesser 10 cm. Gestell schwarz  
lackiert, Durchmesser 62 cm.  
Stromkabel, transparent, cm 120.

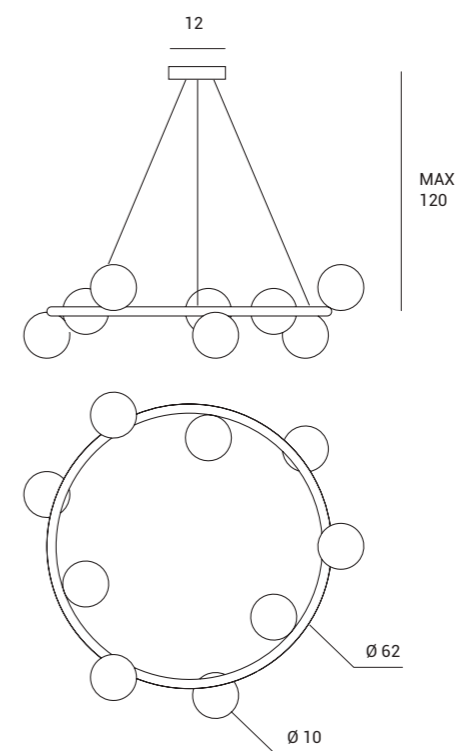

Source

G9

Power

9 x max 40w

# POMÌ

1744.102



Lampada da terra a 5 luci  
in vetro soffiato bianco latte  
diametro cm 10. Montatura  
verniciata nero con particolare  
in ottone spazzolato. Dotata di  
dimmer a piede.  
Altezza lampada cm 170.

5-light floor lamp in milky white  
blown glass, measuring 10 cm  
in diameter. Black painted body  
with brushed brass detail. Equipped  
with foot-operated dimmer switch.  
Lamp height 170 cm.

Pendelleuchte mit 9 Kugelgläsern  
aus geblasenem Glas in Milchweiß,  
Durchmesser 10 cm.  
Gestell schwarz lackiert,  
Durchmesser 62 cm. Stromkabel,  
transparent, cm 120.

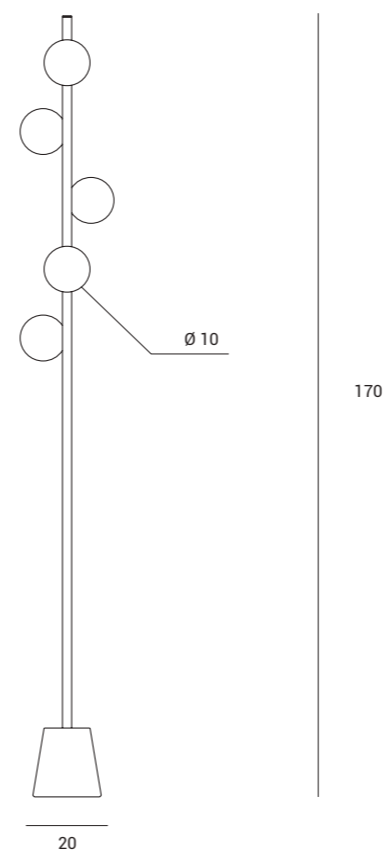

POMÌ

1744.101



Source

G9

Dimmer

Power

5 x max 40w



Lampada da parete in vetro soffiato bianco latte diametro cm 10. Profondità cm 17, altezza totale cm 16. Montatura verniciata nero con particolare in ottone spazzolato.

Wall light in milky white blown glass, measuring 10 cm in diameter. Depth 17 cm, total height 16 cm. Black painted body with brushed brass detail.

Wandleuchte mit Kugelglas aus geblasenem Glas in Milchweiß, Durchmesser 10 cm. Tiefe 17 cm, Gesamthöhe 16 cm. Halterung schwarz lackiert mit Detail aus gebürstetem Messing.



# POMÌ

1744.104

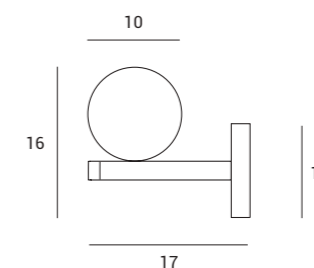

Source

G9

Power

1 x max 40w



Lampada da tavolo in vetro soffiato bianco latte diametro cm 10. Altezza totale lampada cm 28. Montatura verniciata nero con particolare in ottone spazzolato. Cavo di alimentazione nero con dimmer.

Table lamp in milky white blown glass, measuring 10 cm in diameter. Total lamp height 28 cm. Black painted body with brushed brass detail. Black cable with dimmer switch.

Tischleuchte mit Kugelglas aus geblasenem Glas in Milchweiß, Durchmesser 10 cm. Tischleuchtenhöhe 28 cm. Gestell schwarz lackiert mit gebürstetem Messingdetail. Stromkabel schwarz mit Dimmer.



# POMÌ

1744.105

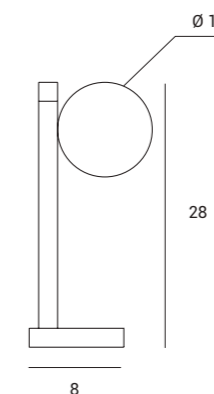

Source

G9

Dimmer

Power

1 x max 40w



Lampada da tavolo a 3 luci  
in vetro soffiato bianco latte  
diametro cm 10, diametro  
base cm 25. Montatura  
verniciata nero con particolare  
in ottone spazzolato.  
Lampada dotata di dimmer.  
Altezza lampada cm 40.

3-light table lamp in milky  
white blown glass, measuring  
10 cm in diameter. 25 cm dia-  
meter base. Black painted body  
with brushed brass detail.  
Lamp equipped with dimmer  
switch. Lamp height 40 cm.

Tischleuchte mit 3  
Kugelgläsern aus geblasenem  
Glas in Milchweiß,  
Durchmesser 10 cm,  
Sockeldurchmesser 25 cm.  
Standfuß schwarz lackiert  
mit gebürstetem Messingdetail.  
Ausgestattet mit Dimmer.  
Tischleuchtenhöhe 40 cm.



# POMÌ

1744.99

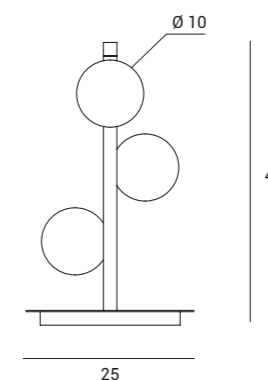

Source

G9

Power

Dimmer

3 x max 40w



Lampada da soffitto a 6 luci in vetro soffiato bianco latte diametro cm 10, base diametro cm 40. Montatura verniciata nero con particolari in ottone spazzolato. Altezza lampada cm 62,5.

6-light ceiling light in milky white blown glass, measuring 10 cm in diameter, 40 cm diameter base. Black painted body with brushed brass details. Lamp height 62,5 cm.

Deckenleuchte mit 6 Kugelgläsern aus geblasenem Glas in Milchweiß, Durchmesser 10 cm, Deckenbaldachindurchmesser 40 cm. Gestell schwarz lackiert mit gebürsteten Messingdetails. Deckenleuchtenhöhe 62,5 cm.

# POMÌ

1744.100

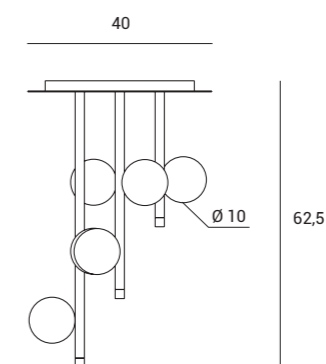

Source

G9

Power

6 x max 40w



Lampada da soffitto a 3 luci  
in vetro soffiato bianco latte  
diametro cm 10. Base tonda  
diametro cm 25, altezza cm 40.  
Montatura verniciata nero  
con particolare in ottone  
spazzolato.

3-light ceiling light in milky white  
blown glass, measuring 10 cm in  
diameter. 25 cm diameter round  
base, height 40 cm. Black painted  
body with brushed brass detail.

Deckenleuchte mit 3 Kugelgläsern  
aus geblasenem Glas in Milchweiß,  
Durchmesser 10 cm.  
Deckenbaldachindurchmesser  
25 cm, Höhe 40 cm. Gestell  
schwarz lackiert mit gebürstetem  
Messingdetail.



# POMÌ

1744.103

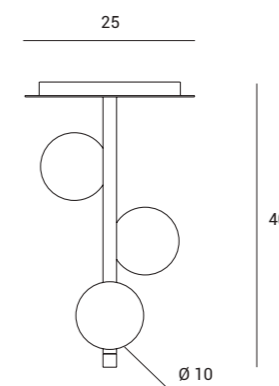

Source

G9

Power

3 x max 40w





Sospensione a 8 luci in vetro borosilicato trasparente esterno e satinato interno, diametro 12 cm. Montatura in metallo verniciato nero con particolare in oro spazzolato. La lampada è dotata di due tubi utilizzabili per alzare e abbassare la lampada stessa.

8-light pendant in borosilicate glass, clear on the outside with frosted finish on the inside, diameter 12 cm. Black painted metal body with detail in brushed gold finish. A light equipped with two poles that can be used to raise or lower the light.

Pendelleuchte mit Glasschirm aus Borosilikatglas außen transparent, innen satiniert, Durchmesser 12 cm. Gestell aus Metall, schwarz pulverbeschichtet mit gebürstetem Goldmetalldetail. Die Leuchte ist mit zwei Rohren ausgestattet, die zum Heben und Senken der Lampe verwendet werden können.

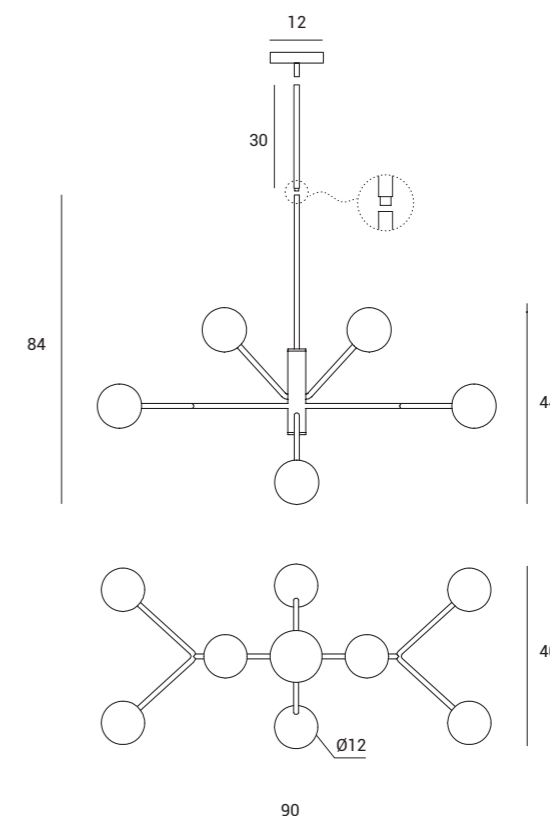

Source

G9

Power

8 x max 40w

# COSMO

1744.164





Lampada da soffitto a 6 luci in vetro borosilicato trasparente esterno e satinato interno, diametro 12 cm. Montatura in metallo verniciato nero con particolare in oro spazzolato.

6-light ceiling light in borosilicate glass, clear on the outside with frosted finish on the inside, diameter 12 cm. Black painted metal body with detail in brushed gold finish.

Deckenleuchte mit 6 Kugelgläsern aus Borosilikatglas, außen transparent, innen satiniert, Durchmesser 12 cm. Gestell aus Metall, schwarz pulverbeschichtet mit gebürstetem Goldmetalldetail.



# COSMO

1744.165

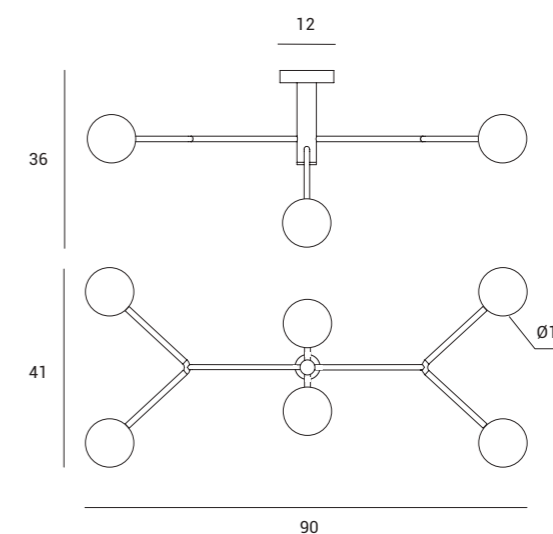

Source

G9

Power

6 x max 40w



Lampada da soffitto a 5 luci in vetro borosilicato trasparente esterno e satinato interno, diametro 12 cm. Montatura in metallo verniciato nero con particolare in oro spazzolato.

5-light ceiling light in borosilicate glass, clear on the outside with frosted finish on the inside, diameter 12 cm. Black painted metal body with detail in brushed gold finish.

Deckenleuchte mit 5 Kugelgläsern aus Borosilikatglas, außen transparent, innen satiniert, Durchmesser 12 cm. Gestell aus Metall, schwarz pulverbeschichtet mit gebürstetem Goldmetalldetail.



# COSMO

1744.166

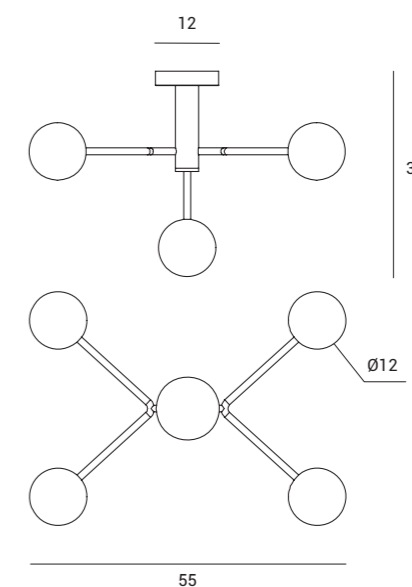

Source

G9

Power

5 x max 40w



Lampada da soffitto in vetro borosilicato trasparente esterno e satinato interno, diametro 12 cm. Montatura in metallo verniciato nero con particolare in oro spazzolato.

Ceiling light in borosilicate glass, clear on the outside with frosted finish on the inside, diameter 12 cm. Black painted metal body with detail in brushed gold finish.

Deckenleuchte aus Borosilikatglas außen transparent, innen satiniert, Durchmesser 12 cm. Halterung aus Metall, schwarz pulverbeschichtet mit gebürstetem Goldmetalldetail.



# COSMO

1744.167

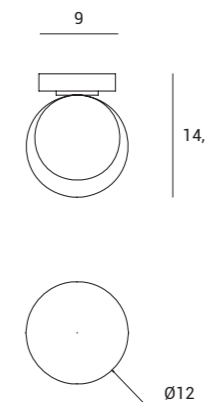

Source

G9

Power

1 x max 40w



Lampada da parete a 2 luci in vetro borosilicato trasparente esterno e satinato interno, diametro 12 cm. Montatura in metallo verniciato nero con particolare in oro spazzolato.

2-light wall light in borosilicate glass, clear on the outside with frosted finish on the inside, diameter 12 cm. Black painted metal body with detail in brushed gold finish.

Wandleuchte mit 2 Kugelgläsern aus Borosilikatglas, außen transparent, innen satiniert, Durchmesser 12 cm. Halterung aus Metall, schwarz pulverbeschichtet mit gebürstetem Goldmetalldetail.



# COSMO

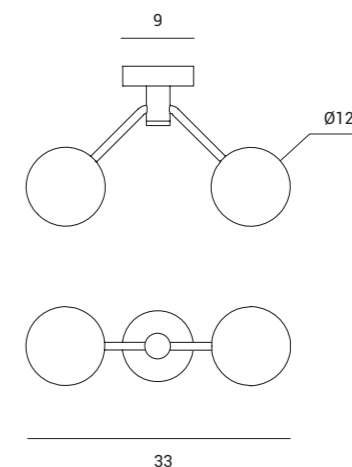

Source

G9

Power

2 x max40w

1744.170

Lampada da parete in vetro borosilicato trasparente esterno e satinato interno, diametro 12 cm. Montatura in metallo verniciato nero con particolare in oro spazzolato.

Wall light in borosilicate glass, clear on the outside with frosted finish on the inside, diameter 12 cm. Black painted metal body with detail in brushed gold finish.

Wandleuchte aus Borosilikatglas, außen transparent, innen satiniert, Durchmesser 12 cm. Halterung aus Metall, schwarz pulverbeschichtet mit gebürstetem Goldmetalldetail.



# COSMO

1744.167

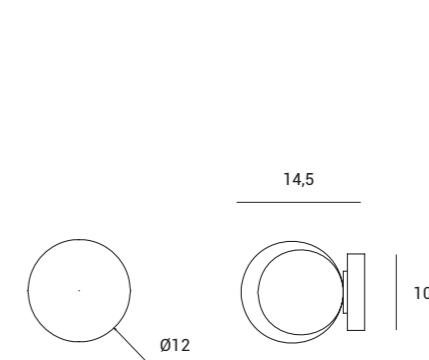

Source

G9

Power

1 x max 40w

Lampada da tavolo a 1 luce in vetro borosilicato trasparente esterno e satinato interno, diametro 12 cm. Montatura in metallo verniciato nero con particolare in oro spazzolato. Cavo trasparente dotato di dimmer.

Single-light table lamp in borosilicate glass, clear on the outside with frosted finish on the inside, diameter 12 cm. Black painted metal body with detail in brushed gold finish. Clear cable, equipped with dimmer switch.

Tischleuchte mit Kugelglas aus Borosilikatglas, außen transparent, innen satiniert, Durchmesser 12 cm. Standfuß aus Metall, schwarz pulverbeschichte mit gebürstetem Goldmetalldetail. Stromkabel, transparent, mit Dimmer.



# COSMO

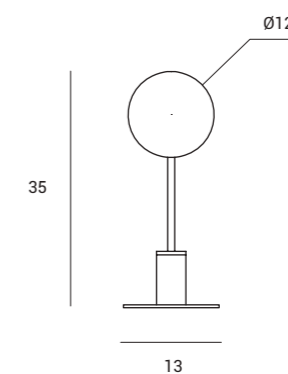

Source

G9

Dimmer

Power

1 x max 40w

1744.171



Lampada da tavolo a 3 luci in vetro borosilicato trasparente esterno e satinato interno, diametro 12 cm. Montatura in metallo verniciato nero con particolare in oro spazzolato. Cavo trasparente dotato di dimmer.

3-light table lamp in borosilicate glass, clear on the outside with frosted finish on the inside, diameter 12 cm. Black painted metal body with detail in brushed gold finish. Clear cable, equipped with dimmer switch.

Tischleuchte mit 3 Kugelgläsern aus Borosilikatglas, außen transparent, innen satiniert, Durchmesser 12 cm. Standfuß aus Metall, schwarz pulverbeschichtet mit gebürstetem Goldmetalldetail. Stromkabel, transparent, mit Dimmer.

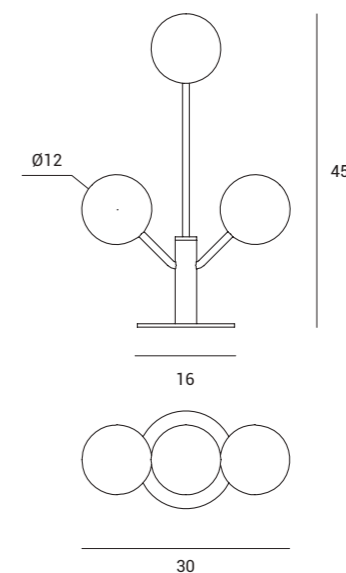

Source

G9

Dimmer

Power

3 x max 40w

# COSMO

1744.169



Lampada da terra a 5 luci in vetro borosilicato trasparente esterno e satinato interno, diametro 12 cm. Montatura in metallo verniciato nero con particolare in oro spazzolato. Cavo trasparente con dimmer.

5-light floor lamp in borosilicate glass, clear on the outside with frosted finish on the inside, diameter 12 cm. Black painted metal body with detail in brushed gold finish. Clear cable with dimmer.

Stehleuchte mit 5 Kugelgläsern aus Borosilikatglas, außen transparent, innen satiniert, Durchmesser 12 cm. Metall-Standfuß, pulverbeschichtet in Schwarz mit gebürstetem Goldmetalldetail. Stromkabel, transparent, mit dimmer.

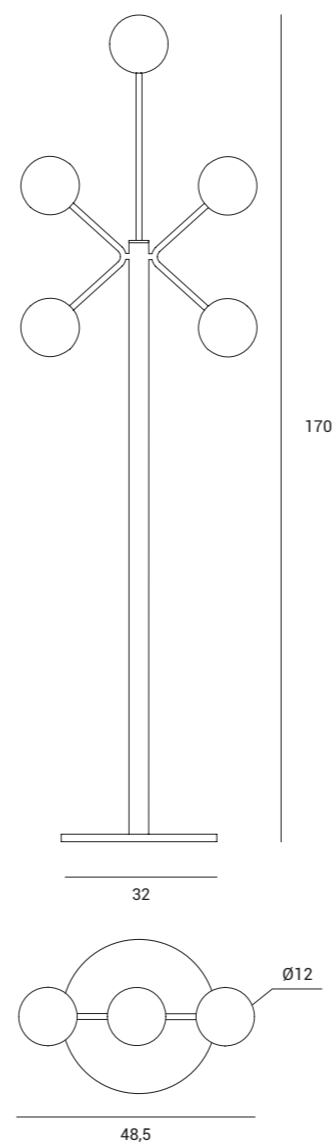

# COSMO

1744.168



Source

G9

Dimmer

Power

5 x max 40w

Sospensione in vetro soffiato  
bianco latte diametro cm 30.  
Montatura verniciata nero.  
Cavo di alimentazione  
trasparente cm 120.

Pendant light in milky white  
blown glass, measuring  
30 cm in diameter.  
Black painted body.  
Clear cable cm 120.

Kugelglas-Pendelleuchte  
aus geblasenem Glas in  
Milchweiß, Durchmesser  
30 cm. Fassungsstruktur  
schwarz lackiert.  
Transparenter Stromkabel,  
120 cm.

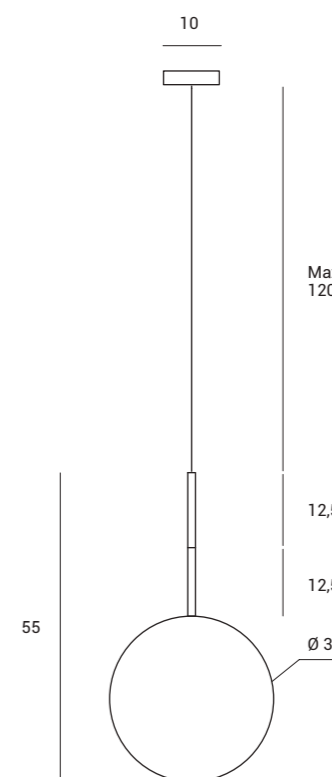

Source

E27

Power

1 x max 40w

# JUGEN BLACK EDITION

1744.205



Lampada da terra a 2 luci  
in vetro soffiato bianco latte  
diametro cm 20.  
Montatura verniciata nero.  
Dotata di dimmer a piede.

Floor lamp with two lights  
in milky white blown glass,  
measuring 20 cm in diameter.  
Black painted body.  
Equipped with foot-operated  
dimmer switch.

Stehleuchte mit 2 Kugelgläsern  
aus geblasenem Glas in  
Milchweiß, Durchmesser 20  
cm. Standfuß schwarz lackiert.  
Inkl. Dimmer mit Fußschalter.

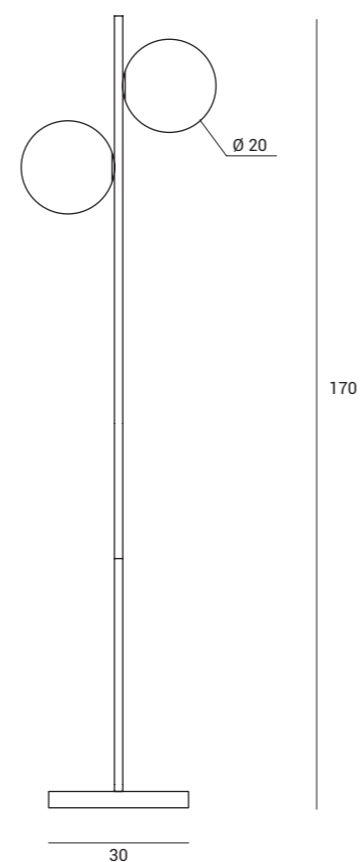

## JUGEN BLACK EDITION

1744.206



Source

E27

Power

Dimmer

2 x max 60w



Lampada da terra in vetro soffiato bianco latte diametro cm 30. Montatura verniciata nero. Dotata di dimmer a piede.

Floor lamp in milky white blown glass, measuring 30 cm in diameter. Black painted body. Equipped with foot-operated dimmer switch.

Kugelglas-Stehleuchte aus geblasenem Glas in Milchweiß, Durchmesser 30 cm. Standfuß schwarz lackiert. Inkl. Dimmer mit Fußschalter.

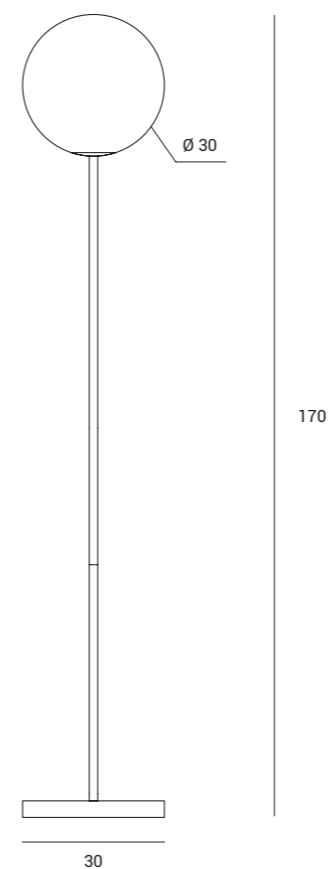

## JUGEN BLACK EDITION

1744.198



Source

E27

Power

Dimmer

1 x max 60w



Sospensione a 2 luci in vetro soffiato bianco latte diametro cm 20. Montatura verniciata nero. Possibilità di utilizzare i tubi di cm 40 e cm 50.

Two lights pendant in milky white blown glass, measuring 20 cm in diameter. Black painted body. It's possible to use the 50 and 40 cm tubes variants.

Hängeleuchte mit 2 Kugelgläsern aus geblasenem Glas in Milchweiß, Durchmesser 20 cm. Gestell schwarz lackiert. Deckenbaldachin aus gebürstetem Messing. Es können 40 cm und 50 cm Rohre verwendet werden.

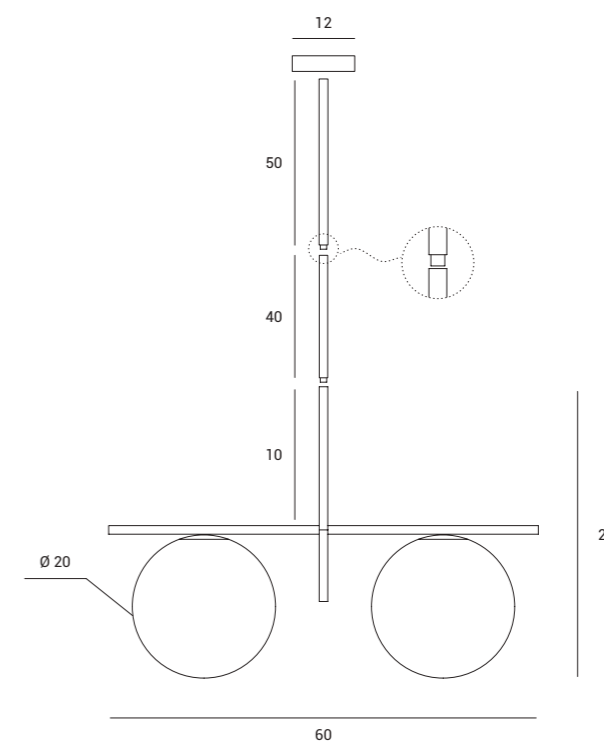

Source

E27

Power

2 x max 40w

JUGEN  
BLACK EDITION

1744.200



Sospensione a 4 luci in vetro soffiato bianco latte diametro cm 20.  
Montatura verniciata nero.  
Possibilità di utilizzare i tubi di cm 40 e cm 50.

Four lights pendant in milky white blown glass, measuring 20 cm in diameter. Black painted body.  
It's possible to use the 50 and 40 cm tubes variants.

Hängeleuchte mit 4 Kugelgläsern aus mundgeblasenem Glas in Milchweiß, Durchmesser 20 cm.  
Gestell schwarz lackiert.  
Deckenbaldachin aus gebürstetem Messing. Es können 40 cm und 50 cm Rohre verwendet werden.



# JUGEN

## BLACK EDITION

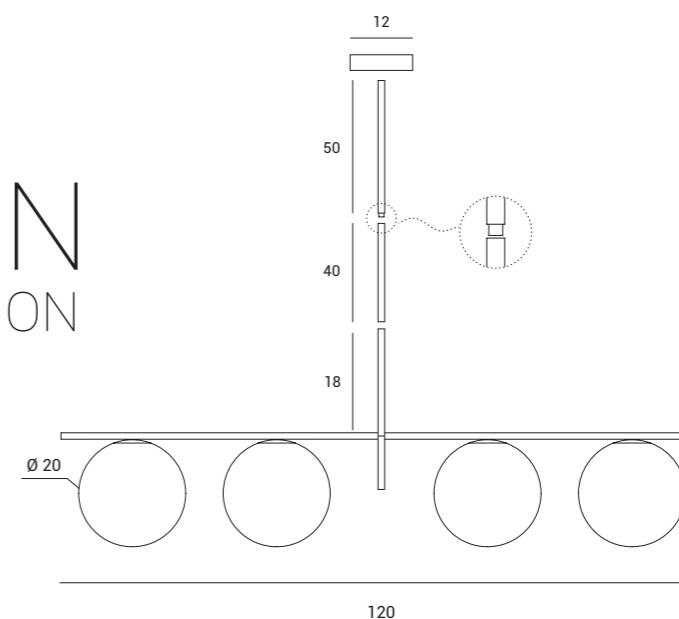

Source

E27

Power

4 x max 40w

1744.204



Lampada da soffitto  
in vetro soffiato bianco latte  
diametro cm 25.  
Montatura verniciata nero.

Ceiling light in milky white  
blown glass, measuring  
25 cm in diameter.  
Black painted body.

Kugelglas-Deckenleuchte aus  
geblasenem Glas in Milchweiß,  
Durchmesser 25 cm.  
Halterung schwarz lackiert.



## JUGEN BLACK EDITION

1744.202

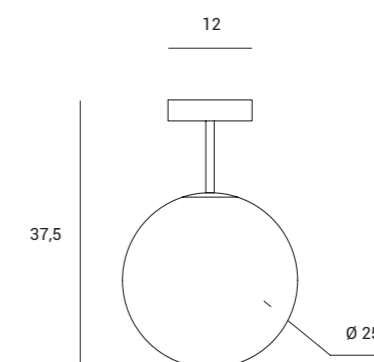

Source

E27

Power

1 x max 40w



Lampada da soffitto a 2 luci  
in vetro soffiato bianco latte  
diametro cm 25. Montatura  
verniciata nero.

Two lights ceiling in milky white  
blown glass, measuring 25 cm in  
diameter. Black painted body.

Deckenleuchte mit 2 Kugelgläsern  
aus geblasenem Glas in Milchweiß,  
Durchmesser 25 cm. Halterung  
schwarz lackiert.



## JUGEN BLACK EDITION

1744.203

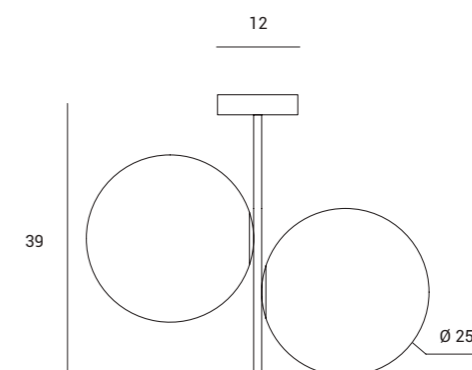

Source

E27

Power

2 x max 40w



Lampada da soffitto a 2 luci  
in vetro soffiato bianco latte  
diametro cm 20.  
Montatura verniciata nero.

Two lights ceiling  
in milky white blown glass,  
measuring 20 cm in diameter.  
Black painted body.

Deckenleuchte mit 2  
Kugelgläsern aus geblasenem  
Glas in Milchweiß, Durchmesser  
20 cm. Gestell schwarz lackiert.



## JUGEN BLACK EDITION

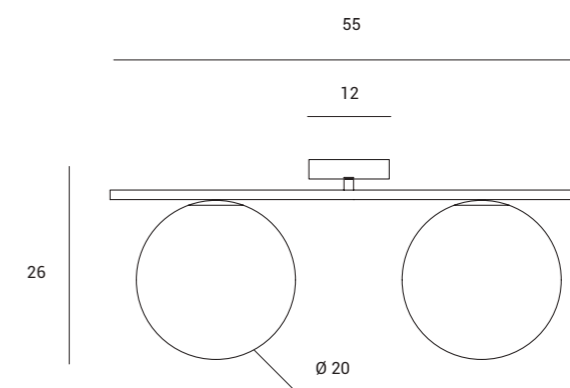

Source

E27

Power

2 x max 40w

1744.201

Lampada da parete in vetro soffiato bianco latte diametro cm 20. Montatura verniciata nero.

Wall light in milky white blown glass, measuring 20 cm in diameter.  
Black painted body.

Kugelglas-Wandleuchte aus geblasenem Glas in Milchweiß, Durchmesser 20 cm.  
Halterung schwarz lackiert.

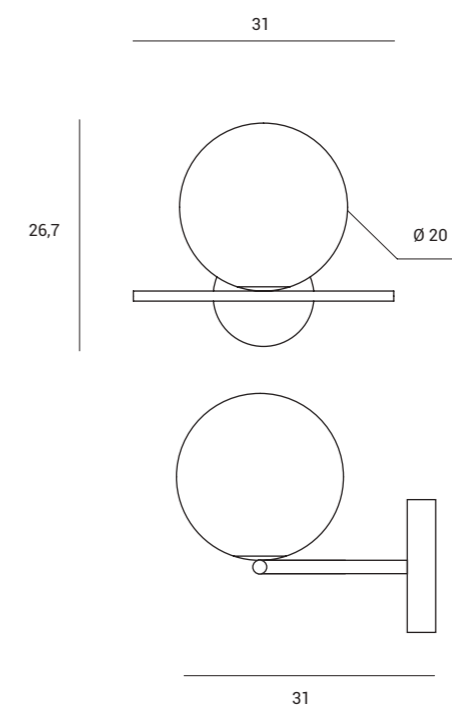

JUGEN  
BLACK EDITION

1744.207



Source

E27

Power

1 x max 40w



Lampada da parete a 2 luci  
in vetro soffiato bianco latte  
diametro cm 15. Montatura  
verniciata nero.

Wall light with two lights  
in milky white blown glass,  
measuring 15 cm in diameter.  
Black painted body.

Wandleuchte mit 2 Kugelgläsern  
aus geblasenem Glas in  
Milchweiß, Durchmesser  
15 cm. Gestell schwarz lackiert.



# JUGEN

## BLACK EDITION

1744.208

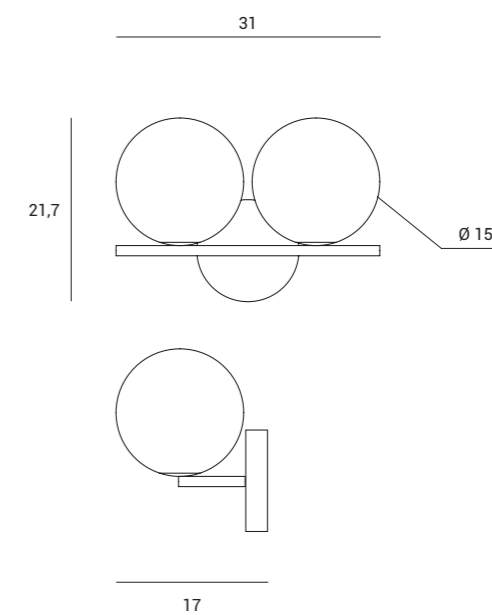

Source

E27

Power

2 x max 40w

Lampada da tavolo  
in vetro soffiato bianco  
latte diametro cm 15.  
Montatura verniciata nero.  
Cavo di alimentazione  
nero con dimmer.

Table lamp in milky white  
blown glass, measuring  
15 cm in diameter.  
Black painted body.

Kugelglas-Tischleuchte aus  
geblasenem Glas in Milchweiß,  
Durchmesser 15 cm.  
Standfuß schwarz lackiert.  
Stromkabel in Schwarz,  
mit Dimmer.



## JUGEN BLACK EDITION

1744.199

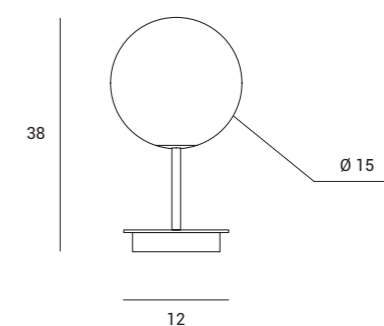

Source

E27

Power

1 x max 40w



Lampada a sospensione in vetro borosilicato color fumè o trasparente, diametro cm 14, altezza cm 20. Stelo e rosone (diametro cm 12) in oro spazzolato. Cavo di alimentazione trasparente cm 120.

Pendant light in clear or smoked borosilicate glass, measuring 14 cm in diameter and 20 cm in height. Brushed gold finish stem and canopy (12 cm in diameter). Clear 120 cm cable.

Pendelleuchte mit Leuchtschirm aus Borosilikatglas, rauchfarben oder transparent, Durchmesser 14 cm, Höhe 20 cm. Pendelrohr und Baldachin (Durchmesser 12 cm), goldfarben, gebürstet. Stromkabel transparent, 120 cm.



1744.88

X-RAY

1744.94

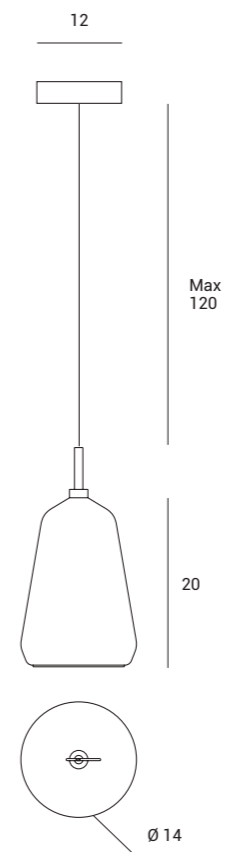

Source

G9

Power

1 x max 40w

Lampada a sospensione in vetro borosilicato color cielo o trasparente, diametro cm 17, altezza cm 18. Stelo e rosone (diametro cm 12) in oro spazzolato. Cavo di alimentazione trasparente cm 120.

Pendant light in clear or sky coloured borosilicate glass, measuring 17 cm in diameter and 18 cm in height. Brushed gold finish stem and canopy (12 cm in diameter). Clear 120 cm cable.

Pendelleuchte mit Leuchtschirm aus Borosilikatglas, Himmelblau oder transparent, Durchmesser 17 cm, Höhe 18 cm. Pendelrohr und Baldachin (Durchmesser 12 cm), goldfarben, gebürstet. Stromkabel transparent, 120 cm.



1744.97

X-RAY

1744.96

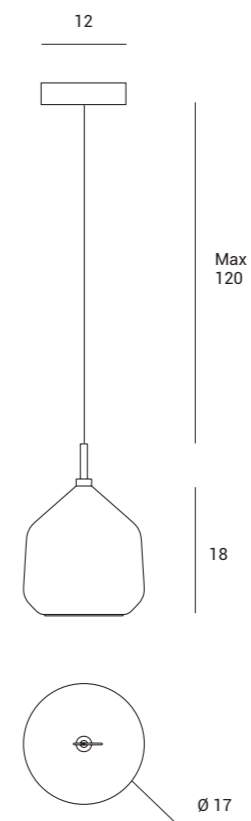

Source

G9

Power

1 x max 40w





Lampada a sospensione in vetro borosilicato color miele o trasparente, diametro cm 20, altezza cm 12. Stelo e rosone (diametro cm 12) in oro spazzolato. Cavo di alimentazione trasparente cm 120.

Pendant light in clear or honey coloured borosilicate glass, measuring 20 cm in diameter and 12 cm in height. Brushed gold finish stem and canopy (12 cm in diameter). Clear 120 cm cable.

Pendelleuchte mit Leuchtschirm aus Borosilikatglas, honigfarben oder transparent, Durchmesser 20 cm, Höhe 12 cm. Pendelrohr und Baldachin (Durchmesser 12 cm), goldfarben, gebürstet. Stromkabel transparent, 120 cm.



1744.90

X-RAY

1744.95

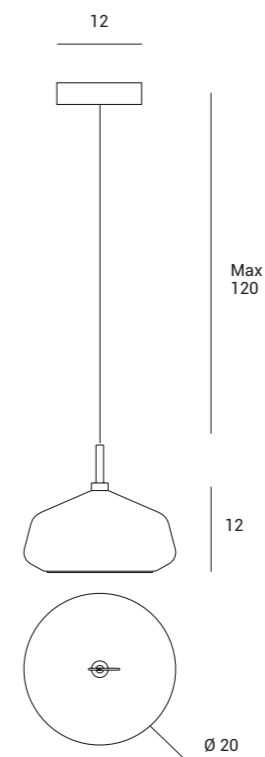

Source

G9

Power

1 x max 40w



Lampada a sospensione a 3 luci in vetro borosilicato. Possibilità di configurare la sospensione con vetri di forme e colore diversi. Rosone in oro spazzolato, (diametro cm 45). Cavo di alimentazione trasparente cm 120.

3-light pendant in borosilicate glass. The pendant light can be configured with glass of different colours and shapes. Brushed gold finish canopy (45 cm in diameter). Clear 120 cm cable.

Pendelleuchte mit 3 Leuchtschirmen aus Borosilikatglas. Kombinationsmöglichkeit mit verschiedenen Schirmformen und verschiedenen Farben. Baldachin goldfarben, gebürstet, (Durchmesser 45 cm). Stromkabel transparent, 120 cm.

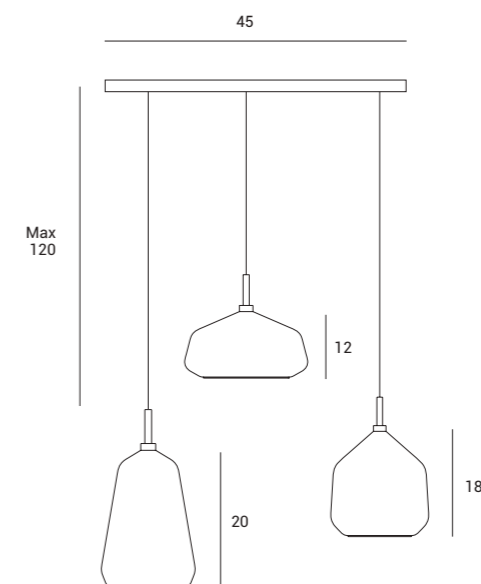
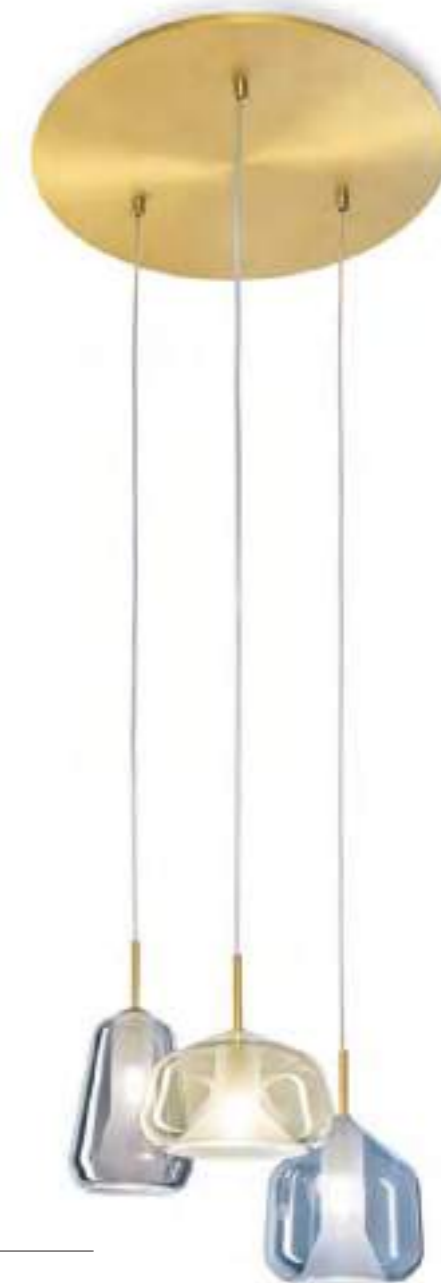

# X-RAY



Source

G9

Power

3 x max 40w



Lampada a sospensione a 6 luci in vetro borosilicato. Possibilità di configurare la sospensione con vetri di forme e colore diversi. Stelo e rosone (diametro cm 60) in oro spazzolato. Cavo di alimentazione trasparente cm 120.

6-light pendant in borosilicate glass. The pendant light can be configured with glass of different colours and shapes. Brushed gold finish stem and canopy (60 cm in diameter). Clear 120 cm cable.

Pendelleuchte mit 6 Leuchtschirmen aus Borosilikatglas. Kombinationsmöglichkeit mit verschiedenen Schirmformen und verschiedenen Farben. Baldachin (Durchmesser 60 cm) goldfarben, gebürstet. Stromkabel transparent, 120 cm.

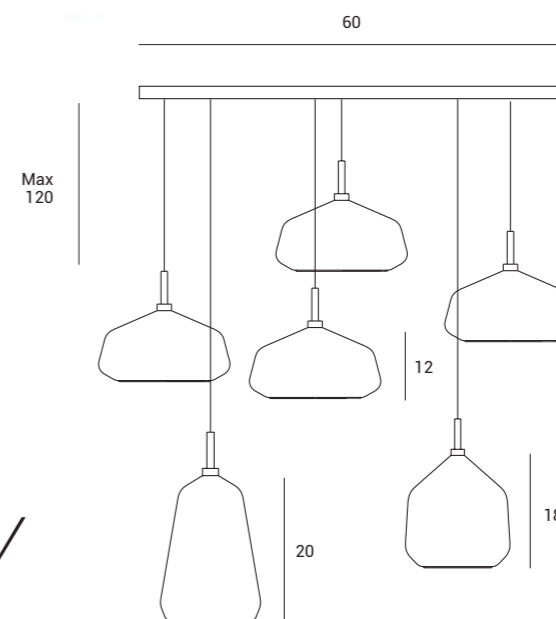

# X-RAY



Source

G9

Power

6 x max 40w





Lampada a sospensione  
a 9 luci in vetro borosilicato.  
Possibilità di configurare  
la sospensione con vetri  
di forme e colore diversi.  
Stelo e rosone di cm 90  
in oro spazzolato.  
Cavo di alimentazione  
trasparente cm 120.

9-light pendant in borosilicate  
glass. The pendant light can be  
configured with glass of different  
colours and shapes. Brushed  
gold finish stem and 90 cm  
canopy. Clear 120 cm cable.

Pendelleuchte mit  
9 Leuchtschirmen  
aus Borosilikatglas.  
Kombinationsmöglichkeit mit  
verschiedenen Schirmformen  
und verschiedenen Farben.  
Baldachin (Durchmesser 90 cm)  
goldfarben, gebürstet.  
Stromkabel transparent, 120 cm.

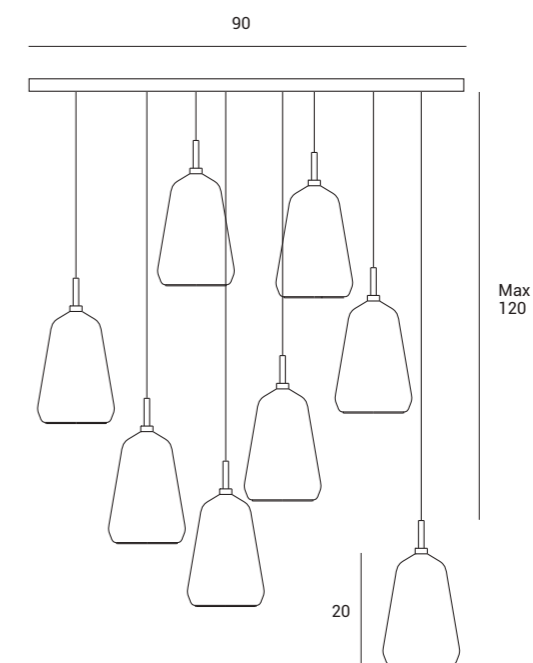

Source

G9

Power

9 x max 40w

# X-RAY

per configurazione del sistema vedere pagina 195/ for system configuration view page 195/  
Systemkonfiguration siehe Seite 195



# X-RAY

KIT PER SOSPENSIONI  
KIT FOR PENDANT LIGHT  
PENDELLEUCHTEN-BAUSATZ

KIT per configurazione personalizzata  
serie di lampade a sospensione X-RAY a 3, 6 e 9 luci.  
Possibilità di configurare la sospensione con vetri in borosilicato  
di forme e colore diversi. Rosone in oro spazzolato per 3, 6 e 9 luci.  
Cavo di alimentazione trasparente cm 120.

KIT for customised configuration  
Range of 3, 6 and 9-light X-RAY pendant lights.  
The pendant light can be customised with borosilicate glass  
of different colours and shapes. Brushed gold finish canopy for 3, 6 and 9 lights.  
Clear 120 cm cable.

BAUSATZ für kundenspezifische Gestaltung.  
Pendelleuchterserie - X-RAY mit 3, 6 und 9 Leuchten.  
Kombinationsmöglichkeit von verschiedenen Leuchtschirmformen  
und Farben. Deckenbaldachine mit 3,6 und 9 Ausgängen, goldfarben, gebürstet.  
Stromkabel transparent, 120 cm.

## TRASPARENTE/CLEAR/TRANSPARENTEM

FORMA/SHAPE/BILDEN

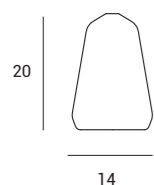

1744.V.120

Composizione fatta da vetro interno satinato + vetro esterno **trasparente**  
Composition made up of satin glass inside and **clear** glass outside  
Kombination von satiniertem Glas innen + **transparentem** Glas außen



FORMA/SHAPE/BILDEN

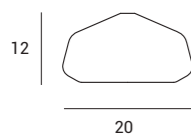

1744.V.118

Composizione fatta da vetro interno satinato + vetro esterno **trasparente**  
Composition made up of satin glass inside and **clear** glass outside  
Kombination von satiniertem Glas innen + **transparentem** Glas außen



FORMA/SHAPE/BILDEN

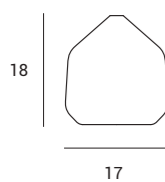

1744.V.119

Composizione fatta da vetro interno satinato + vetro esterno **trasparente**  
Composition made up of satin glass inside and **clear** glass outside  
Kombination von satiniertem Glas innen + **transparentem** Glas außen



## ROSONI A SOFFITTO con parte elettrica / CEILING CANOPIES with electrical part / DECKENLAMPEN mit elektrischem Teil

1744.M.131

Rosone per sospensioni a 3 luci  
for pendant light with 3 light  
Rosette für 3 Lampenpendel  
diametro/diameter/durchmesser  
cm 45.

45



1744.M.132

Rosone per sospensioni a 6 luci  
for pendant light with 6 light  
Rosette für 6 Lampenpendel  
diametro/diameter/durchmesser  
cm 60

60



1744.M.133

rosone per sospensioni a 9 luci  
for pendant light with 9 light  
Rosette für 9 Lampenpendel  
diametro/diameter/durchmesser  
cm 90.

90



## COLORI/COLORS/FARBEN

FORMA/SHAPE/BILDEN

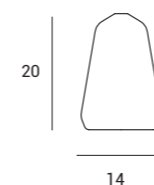

1744.V.130

Composizione fatta da vetro interno satinato + vetro esterno **fumè**  
Composition made up of satin glass inside and **smoked** coloured glass outside  
Kombination von satiniertem Glas innen + **rauchfarbenem** Glas außen



FORMA/SHAPE/BILDEN

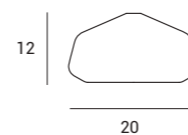

1744.V.129

Composizione fatta da vetro interno satinato + vetro esterno **miele**  
Composition made up of satin glass inside and **honey** coloured glass outside  
Kombination von satiniertem Glas innen + **honigfarbenem** Glas außen



FORMA/SHAPE/BILDEN

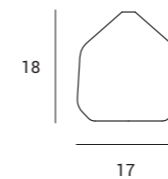

1744.V.128

Composizione fatta da vetro interno satinato + vetro esterno **cielo**  
Composition made up of satin glass inside and **sky** coloured glass outside  
Kombination von satiniertem Glas innen + **himmelblauem** Glas außen



Lampada da tavolo in vetro borosilicato color fumè o trasparente. Montatura in oro spazzolato, altezza lampada cm 39, vetro diametro cm 14. Cavo di alimentazione trasparente con dimmer.

Table lamp in clear or smoked borosilicate glass. Brushed gold finish body, lamp height 39 cm, 14 cm diameter glass. Clear cable with dimmer switch.

Tischleuchte mit Leuchtschirm aus Borosilikatglas, rauchfarben oder transparent. Standfuß goldfarben, gebürstet, Tischleuchtenhöhe 39 cm, Leuchtschirmdurchmesser 14 cm. Stromkabel transparent mit Dimmer.

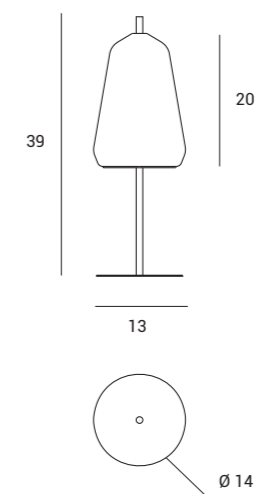

Source

G9

Dimmer

Power

1 x max 40w

# X-RAY

per configurazione del sistema vedere pagina 215/ for system configuration view page 215/  
Systemkonfiguration siehe Seite 215

Lampada da tavolo in vetro borosilicato color cielo o trasparente. Montatura in oro spazzolato, altezza lampada cm 32,5, vetro diametro cm 17. Cavo di alimentazione trasparente con dimmer.

Table lamp in borosilicate glass, clear or sky coloured. Brushed gold finish body, lamp height 32,5 cm, 17 cm diameter glass. Clear cable with dimmer switch.

Tischleuchte mit Leuchtschirm aus Borosilikatglas, Himmelblau oder transparent. Standfuß goldfarben, gebürstet, Tischleuchtenhöhe 32,5 cm, Leuchtschirmdurchmesser 17 cm. Stromkabel transparent mit Dimmer.

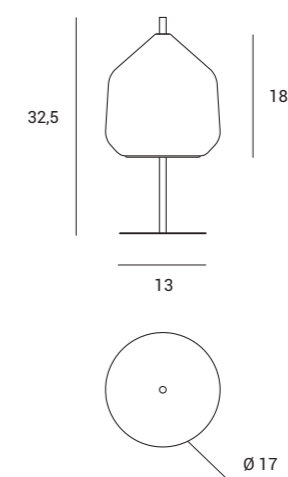

# X-RAY



Source

G9

Power

Dimmer

1 x max 40w

per configurazione del sistema vedere pagina 215/ for system configuration view page 215/  
Systemkonfiguration siehe Seite 215



Lampada da tavolo in vetro borosilicato color miele o trasparente. Montatura in oro spazzolato, altezza lampada cm 34 vetro diametro cm 20. Cavo di alimentazione trasparente con dimmer.

Table lamp in borosilicate glass, clear or honey coloured. Brushed gold finish body, lamp height 34 cm, 20 cm diameter glass. Clear cable with dimmer switch.

Tischleuchte mit Leuchtschirm aus Borosilikatglas, honigfarben oder transparent. Standfuß goldfarben, gebürstet, Tischleuchtenhöhe 34 cm, Leuchtschirmdurchmesser 20 cm. Stromkabel transparent mit Dimmer.

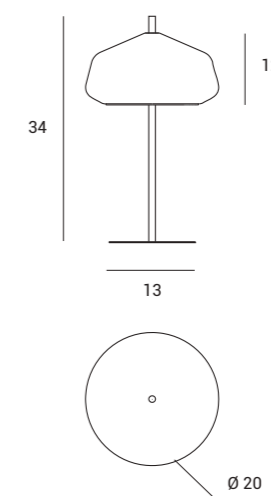

# X-RAY



Source

G9

Power

Dimmer

1 x max 40w

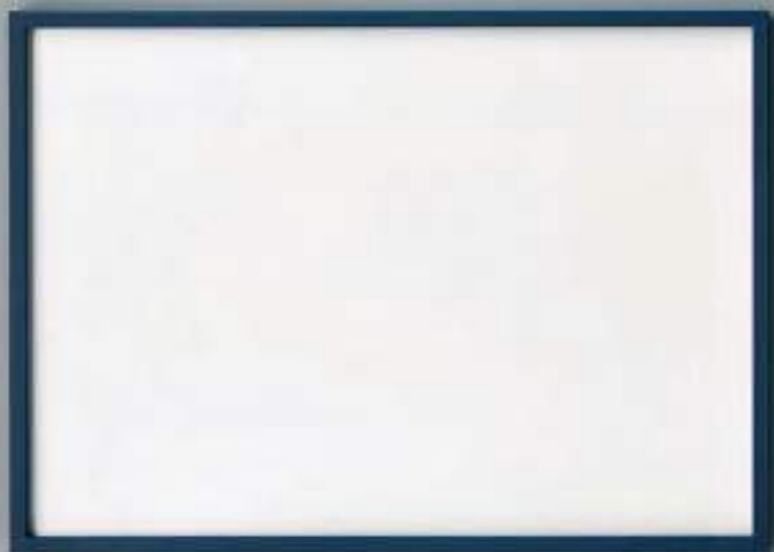



Lampada da parete in vetro borosilicato color fumè o trasparente. Vetro diametro cm 14, altezza totale cm 29. Montatura in oro spazzolato.

Wall light in clear or smoked borosilicate glass. Glass measuring 14 cm in diameter, total height 29 cm. Brushed gold finish body.

Wandleuchte mit Leuchtschirm aus Borosilikatglas in rauchfarben oder transparent. Leuchtschirmdurchmesser 14 cm, Gesamthöhe 29 cm. Halterung goldfarben, gebürstet.



# X-RAY

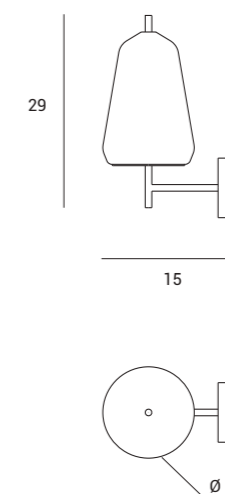

Source

G9

Power

1 x max 40w

per configurazione del sistema vedere pagina 215/ for system configuration view page 215/  
Systemkonfiguration siehe Seite 215





Lampada da parete in vetro borosilicato color cielo o trasparente. Vetro diametro cm 17, altezza totale cm 27,5. Montatura in oro spazzolato.

Wall light in clear or sky coloured borosilicate glass. Glass measuring 17 cm in diameter, total height 27,5 cm. Brushed gold finish body.

Wandleuchte mit Leuchtschirm aus Borosilikatglas in Hellblau oder transparent. Leuchtschirmdurchmesser 17 cm, Gesamthöhe 27,5 cm. Halterung goldfarben, gebürstet.



# X-RAY

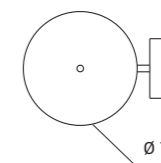
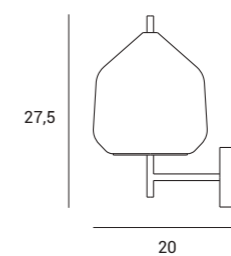

Source

G9

Power

1 x max 40w



Lampada da parete in vetro borosilicato color miele o trasparente. Vetro diametro cm 20, altezza totale cm 20. Montatura in oro spazzolato.

Wall light in clear or honey coloured borosilicate glass. Glass measuring 20 cm in diameter, total height 20 cm. Brushed gold finish body.

Wandleuchte mit Leuchtschirm aus Borosilikatglas honigfarben oder transparent. Leuchtschirmdurchmesser 20 cm, Gesamthöhe 20 cm. Halterung goldfarben, gebürstet.



# X-RAY

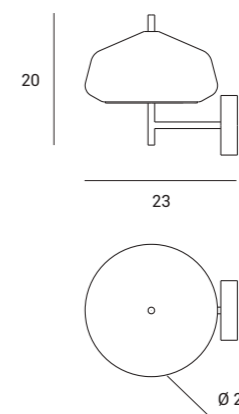

Source

G9

Power

1 x max 40w

per configurazione del sistema vedere pagina 215/ for system configuration view page 215/  
Systemkonfiguration siehe Seite 215

# X-RAY

KIT PER LAMPADE DA TAVOLO  
KIT FOR TABLE LAMP  
KIT FÜR TISCHLAMPEN



Vetro (disponibile in 3 forme diverse) + Base in oro spazzolato  
Glass (available in 3 different shapes) + Base in brushed gold  
Glas (in 3 verschiedenen Formen erhältlich) + Basis aus gebürstetem Gold

VETRO/GLASS/GLAS

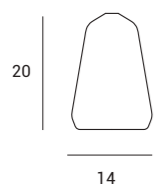

1744.V.120



1744.V.130



BASE/BASE/BASIS

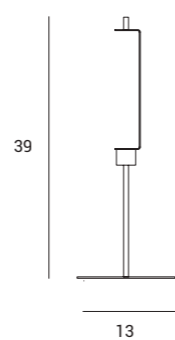

1744.M.134

VETRO/GLASS/GLAS

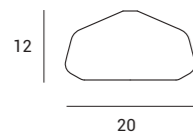

1744.V.118



1744.V.129



BASE/BASE/BASIS

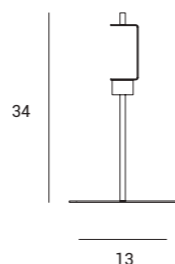

1744.M.136

VETRO/GLASS/GLAS

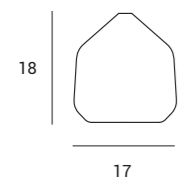

1744.V.119



1744.V.128



BASE/BASE/BASIS

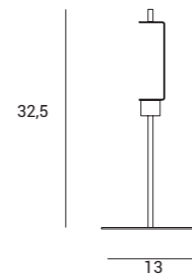

1744.M.135

# X-RAY

KIT PER LAMPADE DA PARETE  
KIT FOR WALL LAMP  
KIT FÜR WANDLAMPEN



Vetro (disponibile in 3 forme diverse) + Attacco parete in oro spazzolato  
Glass (available in 3 different shapes) + Wall mount in brushed gold  
Glas (in 3 verschiedenen Formen erhältlich) + Wandbefestigung aus gebürstetem Gold

VETRO/GLASS/GLAS

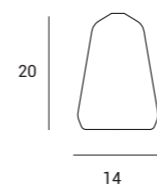

1744.V.120



1744.V.130



ATTACCO/MOUNT/WANDLAMPEN

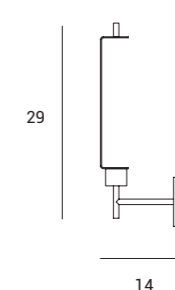

1744.M.128

VETRO/GLASS/GLAS

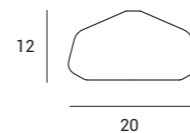

1744.V.118



1744.V.129



ATTACCO/MOUNT/WANDLAMPEN

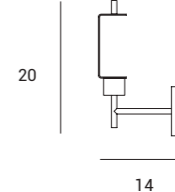

1744.M.128

VETRO/GLASS/GLAS

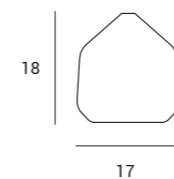

1744.V.119



1744.V.128



ATTACCO/MOUNT/WANDLAMPEN

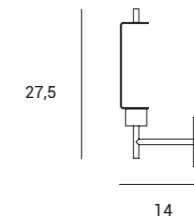

1744.M.128



Sospensione in vetro borosilicato trasparente esterno e satinato interno, diametro 15 cm, altezza cavo cm 200. Rosone e parti metalliche in oro spazzolato.

Pendant light in borosilicate glass, clear on the outside with frosted finish on the inside, diameter 15 cm, cable length 200 cm. Canopy and metallic parts in brushed gold finish. The system allows the power supply to be connected to any canopy.

Kugelpendelleuchte aus Borosilikatglas, Kugelglas außen transparent, innen satiniert, Durchmesser 15 cm, Stromkabellänge 200 cm. Baldachin und alle Metallteile sind goldfarben gebürstet.



# ALADINO

WINNER



1744.139

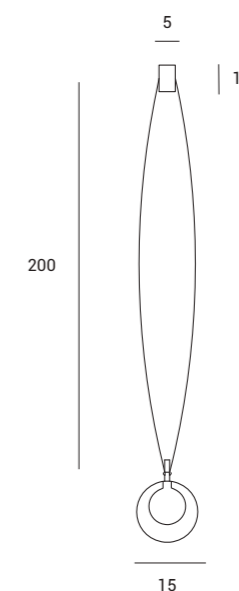

Source

G9

Power

1 x max 40w

Sospensione in vetro borosilicato trasparente esterno e satinato interno, diametro 15 cm, altezza cavo cm 200. Rosone e parti metalliche in oro spazzolato. Il sistema ha la possibilità di prendere l'alimentazione in qualsiasi rosone.

Pendant light in borosilicate glass, clear on the outside with frosted finish on the inside, diameter 15 cm, cable length 200 cm. Canopy and metallic parts in brushed gold finish. The system allows the power supply to be connected to any canopy.

Kugelpendelleuchte aus Borosilikatglas, Kugelglas außen transparent, innen satiniert, Durchmesser 15 cm, Stromkabellänge 200 cm. Baldachin und alle Metallteile sind goldfarben gebürstet. Die Leuchte hat eine Stromzufuhr von beiden Baldachinen aus.

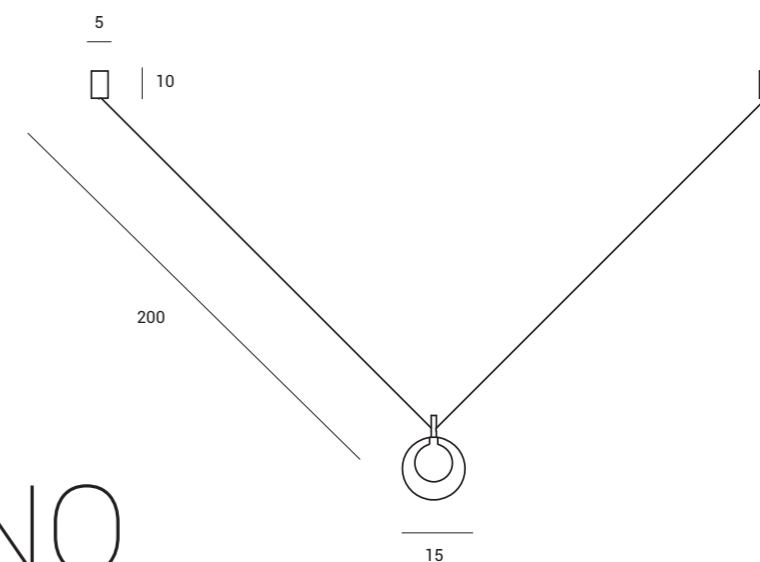

# ALADINO

WINNER



1744.139



Source

G9

Power

1 x max 40w

A



B



**ESEMPI DI POSSIBILI CONFIGURAZIONI / EXAMPLES OF POSSIBLE CONFIGURATIONS /  
GESTALTUNGSMÖGLICHKEITEN**

A

CONFIGURAZIONE  
3 LUCI IN LINEA

3 LIGHTS IN LINEAR  
CONFIGURATION

GESTALTUNG  
3 LINEARE KUGELGLÄSER

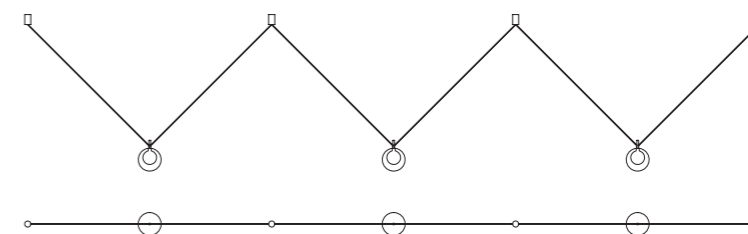

B

CONFIGURAZIONE  
3 LUCI IN TONDO

3 LIGHTS IN CIRCULAR  
CONFIGURATION

GESTALTUNG  
3 KUGELGLÄSER IM KREIS

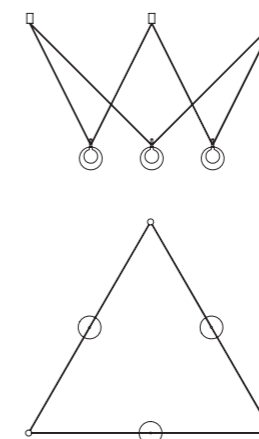

...E MOLTO ALTRO  
...AND MANY MORE  
...UND VIELE WEITERE MÖGLICHKEITEN

# ALADINO

Sospensione a 3 luci in vetro borosilicato trasparente esterno e satinato interno, diametro 15 cm, lunghezza cavo cm 200. Il sistema, composto da parti metalliche in oro spazzolato, ha la possibilità di prendere l'alimentazione in qualsiasi rosone e, attraverso le connessioni, portare illuminazione in ogni punto luce.

3-light pendant in borosilicate glass, clear on the outside with frosted finish on the inside, diameter 15 cm, cable length 200 cm.

The system, composed of metallic parts in a brushed gold finish, is designed to allow the power supply to be connected to any canopy and, through the connections, brings light to every lighting point.

Pendelleuchte mit 3 Kugelgläsern aus Borosilikatglas, außen transparent, innen satiniert, Durchmesser 15 cm, Kabellänge 200 cm. Das Pendelleuchtensystem aus gebürsteten Goldmetallteilen hat die Möglichkeit, die Stromversorgung von beiden Baldachinen aus aufzunehmen.

WINNER



1744.141





WINNER



GOOD  
DESIGN

WINNER







# ALADINO

Sospensione a 5 luci in vetro borosilicato trasparente esterno e satinato interno, diametro 15 cm, lunghezza cavo cm 200. Il sistema, composto da parti metalliche in oro spazzolato, ha la possibilità di prendere l'alimentazione in qualsiasi rosone e, attraverso le connessioni, portare illuminazione in ogni punto luce.

5-light pendant in borosilicate glass, clear on the outside with frosted finish on the inside, diameter 15 cm, cable length 200 cm. The system, composed of metallic parts in a brushed gold finish, is designed to allow the power supply to be connected to any canopy and, through the connections, brings light to every lighting point.

Pendelleuchte mit 5 Kugelgläsern aus Borosilikatglas, außen transparent, innen satiniert, Durchmesser 15 cm, Kabellänge 200 cm. Das Pendelleuchtensystem aus gebürsteten Goldmetallteilen hat die Möglichkeit, die Stromversorgung von beiden Baldachinen aus aufzunehmen und über die Anschlüsse in jede Lichtposition zu leiten.

WINNER



1744.144

## ESEMPI DI POSSIBILI CONFIGURAZIONI / EXAMPLES OF POSSIBLE CONFIGURATIONS / GESTALTUNGSMÖGLICHKEITEN

A

CONFIGURAZIONE  
5 LUCI IN LINEA

5 LIGHTS IN LINEAR  
CONFIGURATION

GESTALTUNG  
5 LINEARE KUGELGLÄSER

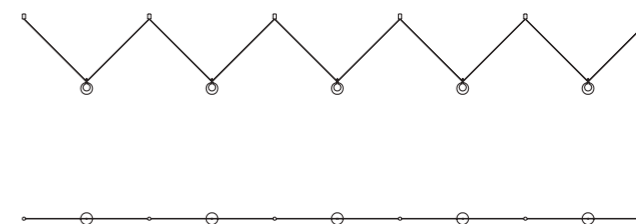

B

CONFIGURAZIONE  
5 LUCI INCROCIATE

5 LIGHTS IN CROSSED  
CONFIGURATION

GESTALTUNG  
5 LINEARE KUGELGLÄSER

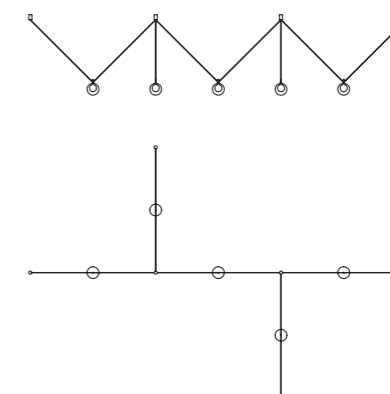

C

CONFIGURAZIONE  
5 LUCI IN TONDO

5 LIGHTS IN CIRCULAR  
CONFIGURATION

GESTALTUNG  
5 LINEARE KUGELGLÄSER

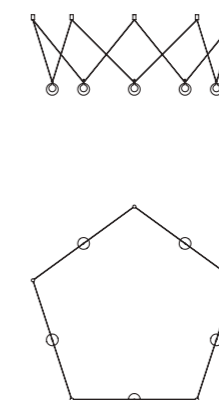

...E MOLTO ALTRO  
...AND MANY MORE  
... UND VIELE WEITERE MÖGLICHKEITEN





WINNER





WINNER





WINNER







# ALADINO

Sospensione a 10 luci in vetro borosilicato trasparente esterno e satinato interno, diametro 15 cm, lunghezza cavo cm 200. Il sistema, composto da parti metalliche in oro spazzolato, ha la possibilità di prendere l'alimentazione in qualsiasi rosone e, attraverso le connessioni, portare illuminazione in ogni punto luce.

10-light pendant in borosilicate glass, clear on the outside with frosted finish on the inside, diameter 15 cm, cable length 200 cm. The system, composed of metallic parts in a brushed gold finish, is designed to allow the power supply to be connected to any canopy and, through the connections, brings light to every lighting point.

Pendelleuchte mit 10 Kugelgläsern aus Borosilikatglas, außen transparent, innen satiniert, Durchmesser 15 cm, Kabellänge 200 cm. Das Pendelleuchtensystem aus gebürsteten Goldmetallteilen hat die Möglichkeit, die Stromversorgung von beiden Baldachinen aufzunehmen und über die Anschlüsse in jede Lichtposition zu leiten.

WINNER



1744.149

## ESEMPI DI POSSIBILI CONFIGURAZIONI / EXAMPLES OF POSSIBLE CONFIGURATIONS / GESTALTUNGSMÖGLICHKEITEN

A

CONFIGURAZIONE  
10 LUCI IN LINEA

10 LIGHTS IN LINEAR  
CONFIGURATION

GESTALTUNG  
10 LINEARE KUGELGLÄSER



B

CONFIGURAZIONE  
10 LUCI A CROCE

10 LIGHTS IN CROSSED  
CONFIGURATION

GESTALTUNG  
10 KUGELGLÄSER KREUZFÖRMIG

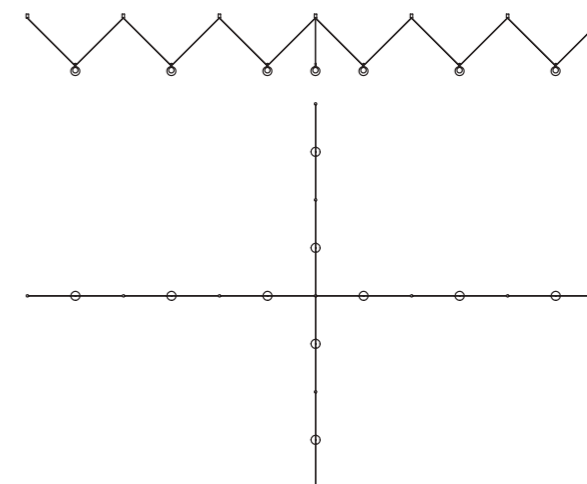

C

CONFIGURAZIONE  
10 LUCI IN RETTANGOLO

10 LIGHTS IN RECTANGULAR  
CONFIGURATION

GESTALTUNG  
10 KUGELGLÄSER IM RECHTECK

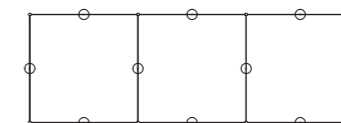

...E MOLTO ALTRO  
...AND MANY MORE  
...UND VIELE WEITERE MÖGLICHKEITEN

WINNER



WINNER







WINNER





A

## ESEMPI DI POSSIBILI CONFIGURAZIONI / EXAMPLES OF POSSIBLE CONFIGURATIONS / GESTALTUNGSMÖGLICHKEITEN

A

CONFIGURAZIONE  
12 LUCI IN RETTANGOLO

12 LIGHTS IN RECTANGULAR  
CONFIGURATION

GESTALTUNG 12 KUGELGLÄSER  
IM RECHTECK

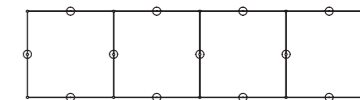

B

B

CONFIGURAZIONE  
12 LUCI IN TONDO

12 LIGHTS IN CIRCULAR  
CONFIGURATION

GESTALTUNG  
12 KUGELGLÄSER IM KREIS

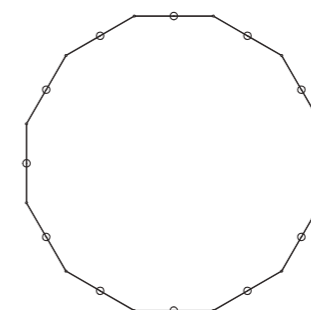

# ALADINO

Sospensione a 12 luci in vetro borosilicato trasparente esterno e satinato interno, diametro 15 cm, lunghezza cavo 200. Il sistema, composto da parti metalliche in oro spazzolato, ha la possibilità di prendere l'alimentazione in qualsiasi rosone e, attraverso le connessioni, portare illuminazione in ogni punto luce.

12-light pendant in borosilicate glass, clear on the outside with frosted finish on the inside, diameter 15 cm, cable length 200 cm. The system, composed of metallic parts in a brushed gold finish, is designed to allow the power supply to be connected to any canopy and, through the connections, brings light to every lighting point.

Pendelleuchte mit 12 Kugelgläsern aus Borosilikatglas, außen transparent, innen satiniert, Durchmesser 15 cm, Kabellänge 200 cm. Das Pendelleuchtensystem aus gebürsteten Goldmetallteilen hat die Möglichkeit, die Stromversorgung von beiden Baldachinen aus aufzunehmen und über die Anschlüsse in jede Lichtposition zu leiten.

WINNER



1744.172

...E MOLTO ALTRO  
...AND MANY MORE  
...UND VIELE WEITERE MÖGLICHKEITEN





WINNER







WINNER



Sospensione in vetro soffiato bianco latte diametro cm 30. Montatura verniciata nero e ottone spazzolato. Cavo di alimentazione trasparente cm 120, rosone in ottone spazzolato.

Pendant light in milky white blown glass, measuring 30 cm in diameter. Black painted and brushed brass finish body. Clear cable cm 120, brushed brass canopy.

Kugelpendelleuchte aus geblasenem Glas in Milchweiß, Durchmesser 30 cm. Fassungsstruktur schwarz lackiert mit gebürstetem Messing. Stromkabel transparent, 120 cm. Baldachin aus gebürstetem Messing.

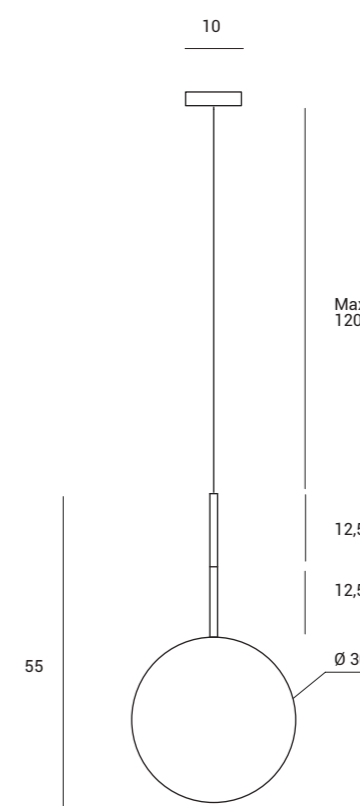

Source

E27

Power

1 x max 40w

# JUGEN

1744.70





Sospensione a 2 luci in vetro soffiato bianco latte diametro cm 20. Montatura verniciata nero e ottone spazzolato. Rosone in ottone spazzolato.

Two lights pendant in milky white blown glass, measuring 20 cm in diameter. Black painted and brushed brass finish body. Brushed brass canopy.

Hängeleuchte mit 2 Kugelgläsern aus geblasenem Glas in Milchweiß, Durchmesser 20 cm. Gestell schwarz lackiert und gebürstetes Messing. Baldachin aus gebürstetem Messing.

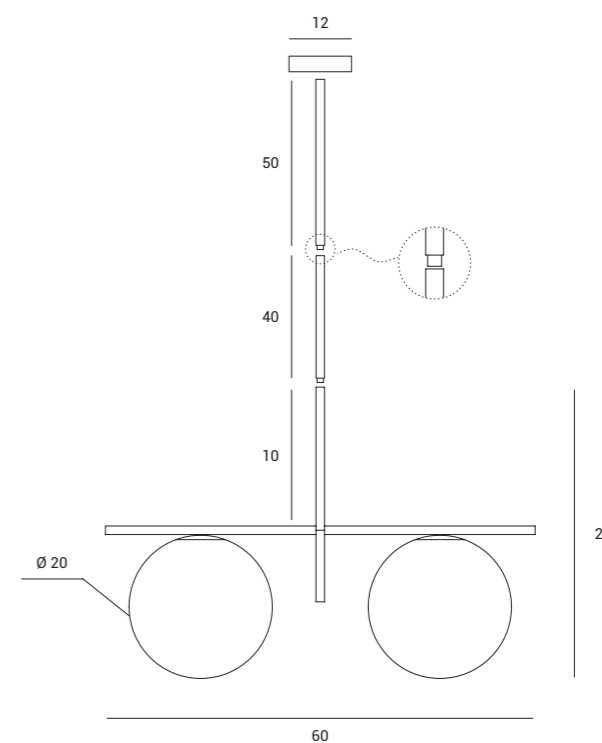

Source

E27

Power

2 x max 40w

# JUGEN

1744.64





Sospensione a 4 luci in vetro soffiato bianco latte diametro cm 20. Montatura verniciata nero e ottone spazzolato. Rosone in ottone spazzolato.

Four lights pendant in milky white blown glass, measuring 20 cm in diameter. Black painted and brushed brass finish body. Brushed brass canopy.

Hängeleuchte mit 4 Kugelgläsern aus geblasenem Glas in Milchweiß, Durchmesser 20 cm. Gestell schwarz lackiert und gebürstetes Messing. Baldachin aus gebürstetem Messing.

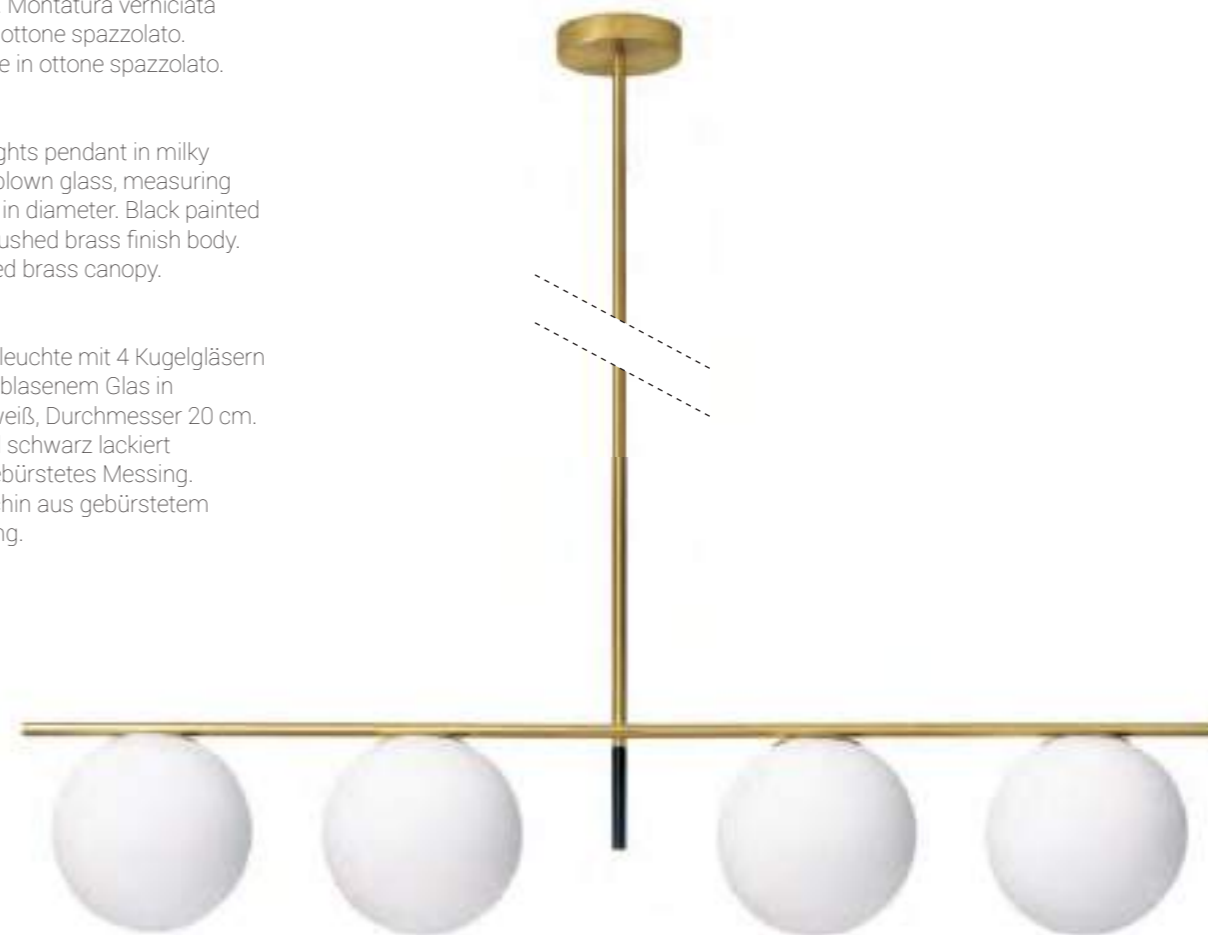

# JUGEN

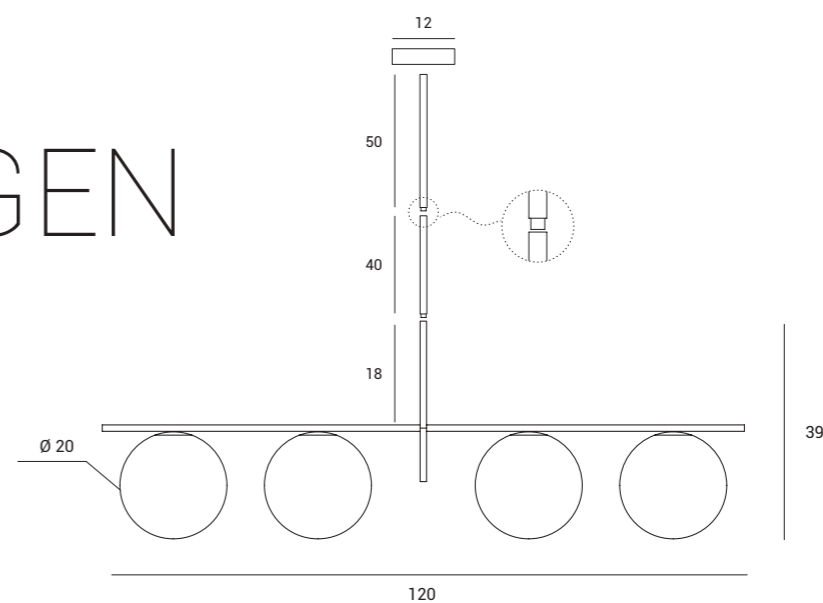

Source

E27

Power

4 x max 40w

1744.68



Lampada da soffitto in vetro soffiato bianco latte diametro cm 25. Montatura in ottone spazzolato.

Ceiling light in milky white blown glass, measuring 25 cm in diameter. Brushed brass finish body.

Deckenleuchte aus geblasenem Kugelglas in Milchweiß, Durchmesser 25 cm. Halterung aus gebürstetem Messing.



# JUGEN

1744.66

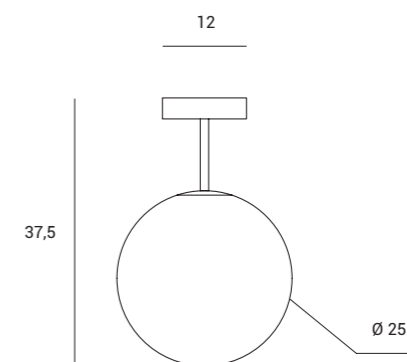

Source

E27

Power

1 x max 40w



Lampada da soffitto a 2 luci in vetro soffiato bianco latte diametro cm 25. Montatura in ottone spazzolato.

Two lights ceiling in milky white blown glass, measuring 25 cm in diameter. Brushed brass finish body.

Deckenleuchte mit 2 Kugelgläsern aus geblasenem Glas in Milchweiß, Durchmesser 25 cm. Halterung aus gebürstetem Messing.



# JUGEN

1744.67

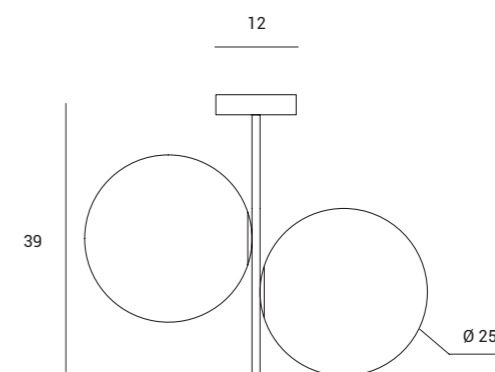

Source

E27

Power

2 x max 40w



Lampada da soffitto a 2 luci  
in vetro soffiato bianco latte  
diametro cm 20. Montatura  
in ottone spazzolato.

Two lights ceiling in milky  
white blown glass, mea-  
suring 20 cm in diameter.  
Brushed brass finish body.

Deckenleuchte mit  
2 Kugelgläsern aus  
geblasenem Glas in  
Milchweiß Durchmesser  
20 cm. Halterung aus  
gebürstetem Messing.



# JUGEN

1744.65

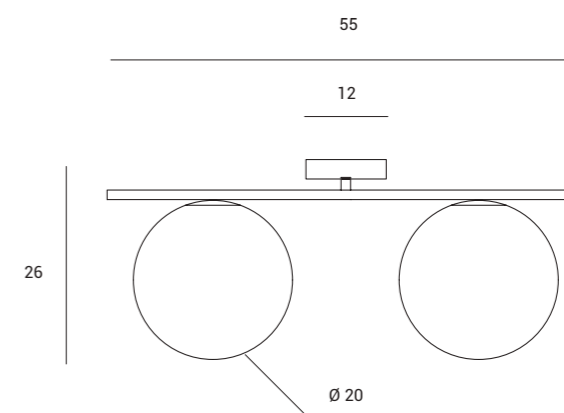

Source

E27

Power

2 x max 40w

Lampada da parete in vetro soffiato bianco latte diametro cm 20. Montatura in ottone spazzolato.

Wall light in milky white blown glass, measuring 20 cm in diameter. Brushed brass fixture.

Wandleuchte mit geblasenem Kugelglas in Milchweiß, Durchmesser 20 cm. Halterung aus gebürstetem Messing.

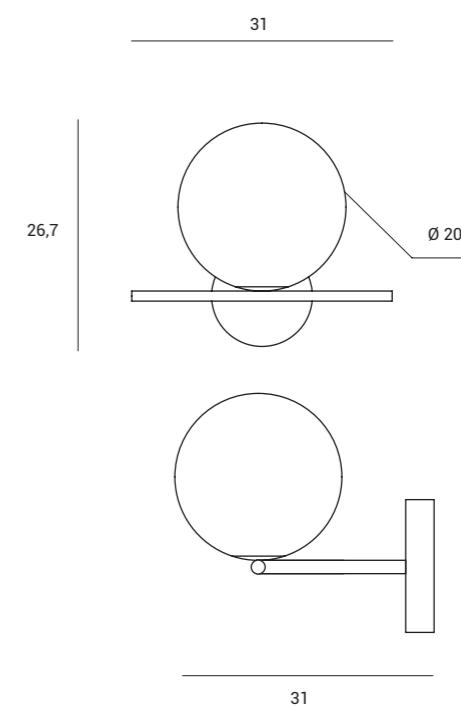

# JUGEN

1744.72



Source

E27

Power

1 x max 40w



Lampada da parete a 2 luci  
in vetro soffiato bianco latte  
diametro cm 15. Montatura  
in ottone spazzolato.

Wall light with two lights  
in milky white blown glass,  
measuring 15 cm in diameter.  
Brushed brass fixture.

Deckenleuchte mit 2  
Kugelgläsern aus geblasenem  
Glas in Milchweiß, Durchmesser  
15 cm. Gestell aus  
gebürstetem Messing.



# JUGEN

1744.73

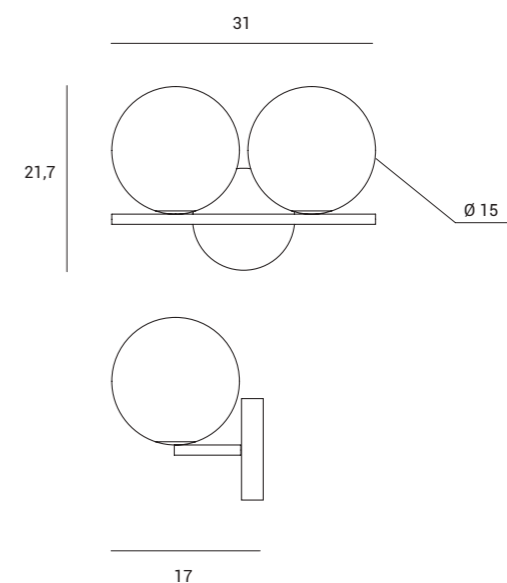

Source

E27

Power

2 x max 40w





Lampada da tavolo in vetro soffiato bianco latte diametro cm 15. Montatura verniciata nero e ottone spazzolato. Cavo di alimentazione nero con dimmer.

Table lamp in milky white blown glass, measuring 15 cm in diameter. Black painted and brushed brass finish body. Black cable with dimmer switch.

Tischleuchte mit Kugelglas aus geblasenem Glas in Milchweiß, Durchmesser 15 cm. Standfuß schwarz lackiert und gebürstetes Messing. Stromkabel schwarz, mit Dimmer.



# JUGEN

1744.63

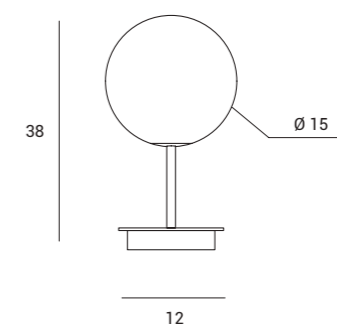

Source

E27

Power

Dimmer

1 x max 40w

Lampada da terra in vetro soffiato bianco latte diametro cm 30. Montatura nero verniciato e ottone spazzolato. Dotata di dimmer a piede.

Floor lamp in milky white blown glass, measuring 30 cm in diameter. Black painted and brushed brass finish body. Equipped with foot-operated dimmer switch.

Stehleuchte mit Kugelglas aus geblasenem Glas in Milchweiß, Durchmesser 30 cm. Standfuß schwarz lackiert und gebürstetes Messing. Inkl. Dimmer mit Fußschalter.

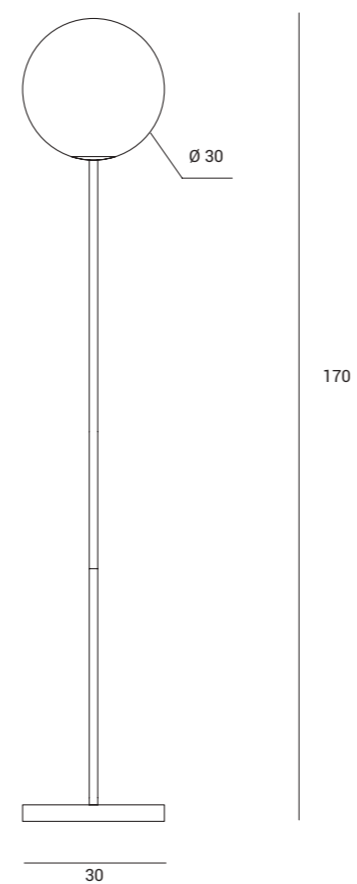

# JUGEN

1744.62



Source

E27

Dimmer

Power

1 x max 60w

Lampada da terra a 2 luci in vetro soffiato bianco latte diametro cm 20. Montatura nero verniciato e ottone spazzolato. Dotata di dimmer a piede.

Floor lamp with two lights in milky white blown glass, measuring 20 cm in diameter. Black painted and brushed brass finish body. Equipped with foot-operated dimmer switch.

Stehleuchte mit 2 Kugelgläsern aus geblasenem Glas in Milchweiß, Durchmesser 20 cm. Standfuß aus schwarz lackiertem Metall und gebürstetem Messing. Inkl. Dimmer mit Fußschalter.

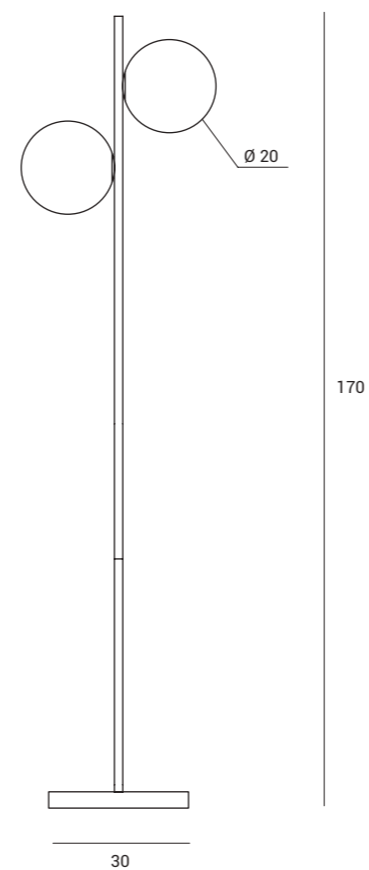

# JUGEN

1744.71



Source

E27

Dimmer

Power

2 x max 60w



Lampada da tavolo in vetro soffiato bianco latte diametro cm 12.  
Montatura in ottone spazzolato.  
Cavo di alimentazione trasparente con dimmer.

Table lamp in milky white blown glass, measuring 12 cm in diameter. Brushed brass body.  
Clear cable with dimmer switch.

Tischleuchte mit Kugelglas aus geblasenem Glas in Milchweiß, Durchmesser 12 cm. Standfuß aus gebürstetem Messing. Stromkabel transparent mit Dimmer.



# LUNAR

1744.150

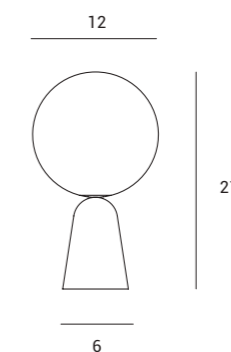

Source

G9

Dimmer

Power

1 x max 40w

Lampada da tavolo in vetro soffiato bianco latte diametro cm 20. Montatura in ottone spazzolato. Cavo di alimentazione trasparente con dimmer.

Table lamp in milky white blown glass, measuring 20 cm in diameter. Brushed brass body. Clear cable with dimmer switch.

Tischleuchte mit Kugelglas aus geblasenem Glas in Milchweiß, Durchmesser 20 cm. Standfuß aus gebürstetem Messing. Stromkabel transparent mit Dimmer.



# LUNAR

1744.151

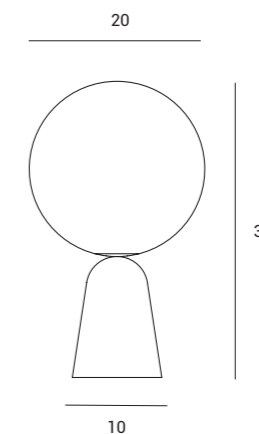

Source

E14

Dimmer

Power

1 x max 40w



Lampada da tavolo in vetro soffiato bianco latte diametro cm 30. Montatura in ottone spazzolato. Cavo di alimentazione trasparente con dimmer.

Table lamp in milky white blown glass, measuring 30 cm in diameter. Brushed brass body. Clear cable with dimmer switch.

Tischleuchte mit Kugelglas aus geblasenem Glas in Milchweiß, Durchmesser 30 cm. Standfuß aus gebürstetem Messing. Stromkabel transparent mit Dimmer.



# LUNAR

1744.152

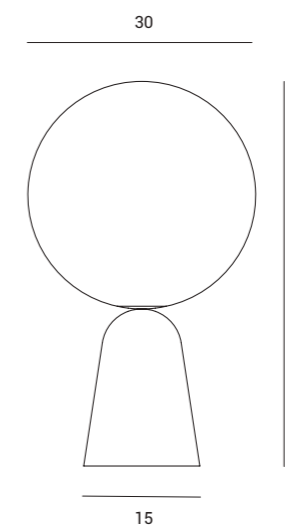

Source

E27

Dimmer

Power

1 x max 40w



Lampada da soffitto in vetro soffiato bianco latte diametro cm 12. Montatura in ottone spazzolato.

Ceiling light in milky white blown glass, measuring 12 cm in diameter. Brushed brass finish body.

Deckenleuchte mit Kugelglas aus geblasenem Glas in Milchweiß, Durchmesser 12 cm. Halterung aus gebürstetem Messing.



# LUNAR

1744.153

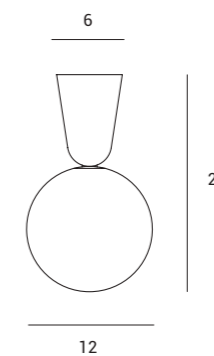

Source

G9

Power

1 x max 40w



Lampada da soffitto in vetro soffiato bianco latte diametro cm 20. Montatura in ottone spazzolato.

Ceiling light in milky white blown glass, measuring 20 cm in diameter. Brushed brass finish body.

Deckenleuchte mit Kugelglas aus geblasenem Glas in Milchweiß, Durchmesser 20 cm. Halterung aus gebürstetem Messing.



# LUNAR

1744.154

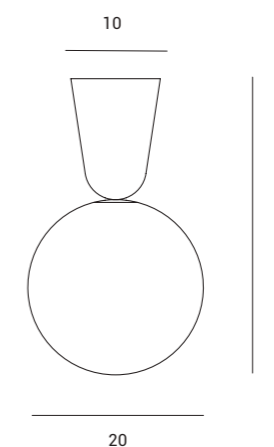

Source

E14

Power

1 x max 40w

Lampada da soffitto in vetro soffiato bianco latte diametro cm 30. Montatura in ottone spazzolato.

Ceiling light in milky white blown glass, measuring 30 cm in diameter. Brushed brass finish body.

Deckenleuchte mit Kugelglas aus geblasenem Glas in Milchweiß, Durchmesser 30 cm. Halterung aus gebürstetem Messing.



# LUNAR

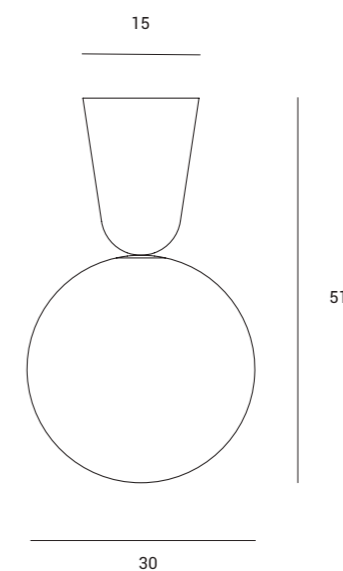

Source

E27

Power

1 x max 40w

1744.155



Sospensione in vetro soffiato bianco latte diametro cm 25.  
Montatura in ottone spazzolato diametro cm 50.  
Cavo di alimentazione nero e rosone in ottone spazzolato.  
Cavi di acciaio di cm 120.

Pendant light in milky white blown glass, measuring 25 cm in diameter. Brushed brass body, measuring 50 cm in diameter.  
Black cable and brushed brass canopy. 120 cm steel cables.

Kugelpendelleuchte aus geblasenem Glas in Milchweiß, Durchmesser 25 cm.  
Fassungsstruktur aus gebürstetem Messing, Durchmesser 50 cm.  
Stromkabel in Schwarz und Baldachin aus gebürstetem Messing. Stromkabel transparent, 120 cm.

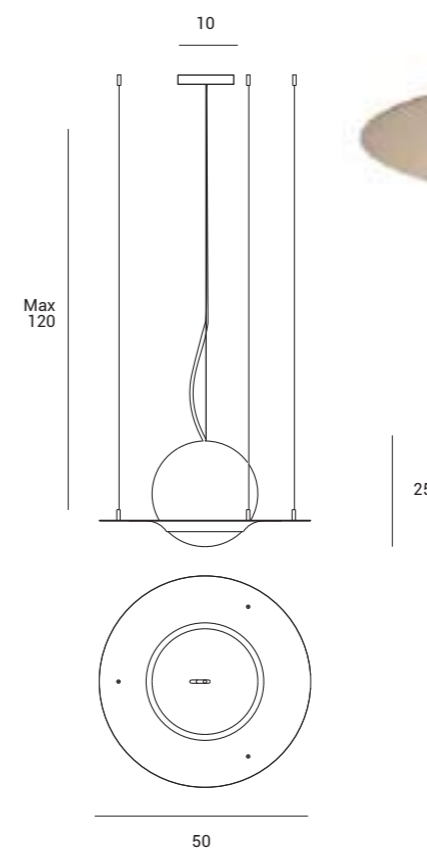
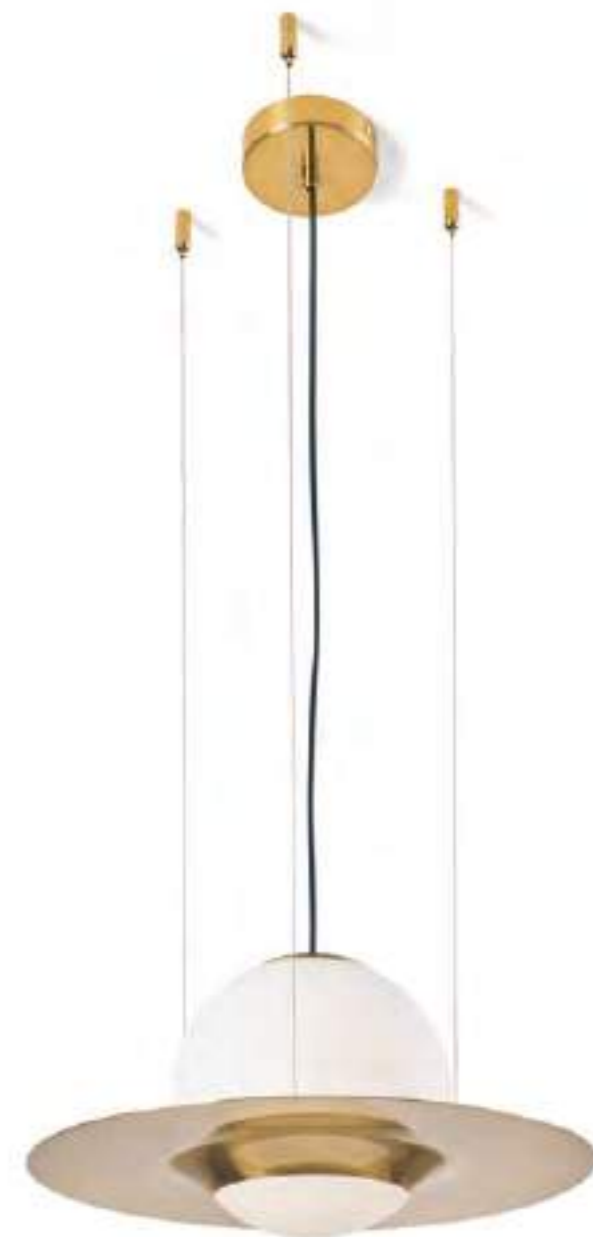

# HAT

1744.89



Source

E27

Power

1 x max 40w



Lampada da soffitto in vetro soffiato bianco latte diametro cm 15. Montatura in ottone spazzolato diametro cm 30.

Ceiling light in milky white blown glass, measuring 15 cm in diameter. Brushed brass body, measuring 30 cm in diameter.

Deckenleuchte aus geblasenem Glas in Milchweiß, Durchmesser 15 cm. Halterung aus gebürstetem Messing, Durchmesser 30 cm.



# HAT

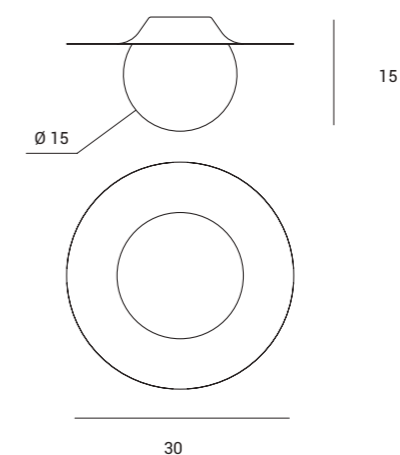

Source

G9

Power

1 x max 40w

1744.93



Lampada da soffitto in vetro soffiato bianco latte diametro cm 25. Montatura in ottone spazzolato diametro cm 50.

Ceiling light in milky white blown glass, measuring 25 cm in diameter. Brushed brass finish body 50 cm in diameter.

Deckenleuchte aus geblasenem Glas in Milchweiß, Durchmesser 25 cm. Halterung aus gebürstetem Messing, Durchmesser 50 cm.



# HAT

1744.91

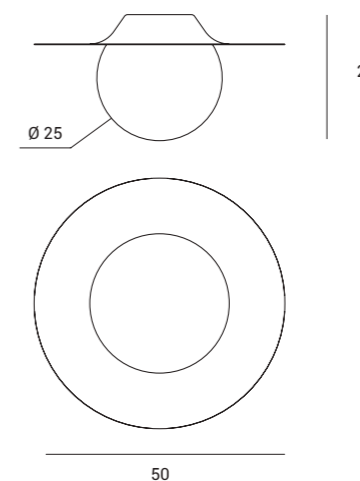

Source

E27

Power

1 x max 40w





Applique da parete in vetro soffiato bianco latte diametro cm 15. Montatura in ottone spazzolato diametro cm 30.

Wall light in milky white blown glass, measuring 15 cm in diameter. Brushed brass fixture 30 cm in diameter.

Deckenleuchte aus geblasenem Glas in Milchweiß, Durchmesser 25 cm. Halterung aus gebürstetem Messing, Durchmesser 50 cm.



# HAT

1744.93

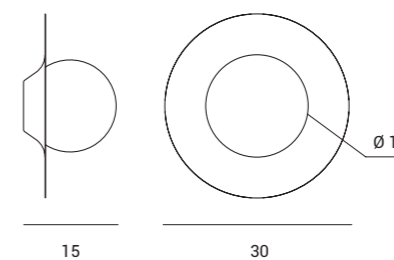

Source

G9

Power

1 x max 40w



Lampada da parete a 1 luce  
in vetro soffiato bianco latte  
diametro cm 25. Montatura  
in ottone spazzolato diametro  
cm 50.

Wall light in milky white blown  
glass, measuring 25 cm in dia-  
meter. Brushed brass fixture  
50 cm in diameter.

Deckenleuchte aus  
geblasenem Glas in Milchweiß,  
Durchmesser 25 cm.  
Halterung aus gebürstetem  
Messing, Durchmesser 50 cm.



# HAT

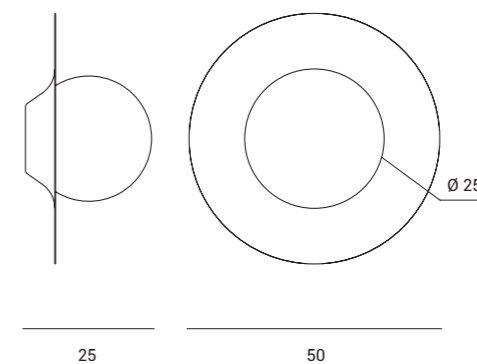

Source

E27

Power

1 x max 40w

1744.91



Lampada da tavolo in vetro soffiato bianco latte diametro cm 15. Montatura in ottone spazzolato diametro 30 cm. Cavo di alimentazione trasparente con dimmer.

Table lamp in milky white blown glass, measuring 15 cm in diameter. Brushed brass body, measuring 30 cm in diameter. Clear cable with dimmer switch.

Deckenleuchte aus geblasenem Glas in Milchweiß, Durchmesser 25 cm. Halterung aus gebürstetem Messing, Durchmesser 30 cm.



# HAT

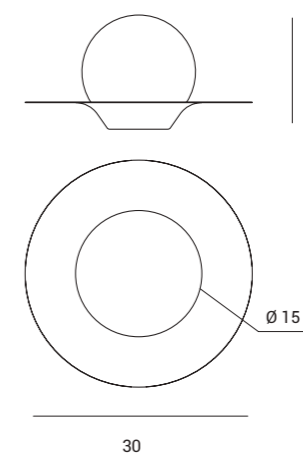

Source

G9

Dimmer

Power

1 x max 40w

1744.92



Lampada a sospensione con struttura in ottone spazzolato e diffusore in vetro soffiato bianco opale. Cavo elettrico rivestito con guaina in PVC colore trasparente di cm 120.

Pendant light with brushed brass body and opal white blown glass diffuser. Clear cable in PVC cm 120.

Pendelleuchte mit Gestell aus gebürstetem Messing und Leuchtschirm aus geblasenem Glas in Opalweiß. Stromkabel transparent, PVC-ummantelt, 120 cm lang.

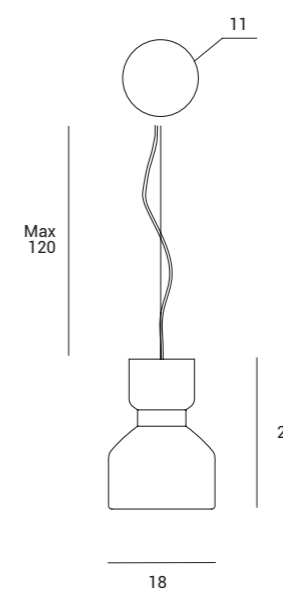

Source

E14

Power

1 x max 40w

FIFTY

1744.19

Lampada a sospensione a 3 luci,  
struttura e rosone in ottone spazzolato.  
Diffusore in vetro soffiato bianco opale.  
Cavo di acciaio e di alimentazione  
trasparente cm 120.

Three lights pendant, structure  
and canopy in brushed brass.  
Opal white blown glass diffuser.  
Steel wires and clear cables cm 120.

Pendelleuchte mit 3 Leuchtschirmen.  
Fassung und Baldachin aus  
gebürstetem Messing. Leuchtschirme  
aus geblasenem Glas in Opalweiß.  
Stahl- und Stromkabel transparent,  
120 cm.

1744.M.47



1744.19

# FIFTY

1 x 1744.M.47  
3 x 1744.19

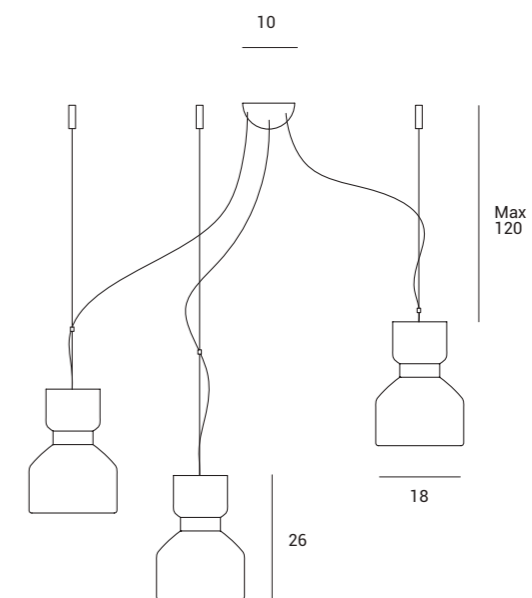

Source

E14

Power

3 x max 40w



Lampada da parete con struttura in ottone spazzolato e diffusore in vetro soffiato bianco opale. Punto luce orientabile.

Wall light with brushed brass body and opal white blown glass diffuser. Adjustable light point.

Wandleuchte mit Halterung aus gebürstetem Messing und Leuchtschirm aus geblasenem Glas in Opalweiß. Orientierbarer Lichtpunkt.



# FIFTY

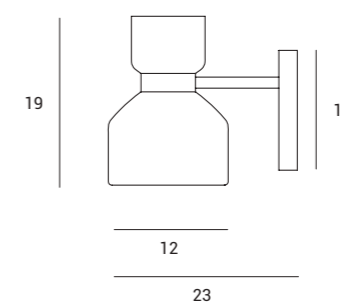

Source

E14

Power

1 x max 40w

1744.17





Lampada da tavolo con struttura in ottone spazzolato e diffusore in vetro soffiato bianco opale. Cavo elettrico rivestito con guaina in PVC colore trasparente. Dotata di pulsante. Punto luce orientabile.

Table lamp with brushed brass body and opal white blown glass diffuser. Clear cables in PVC. Equipped with an on/off switch. Adjustable light source.

Tischleuchte mit Standfuß aus gebürstetem Messing und Leuchtschirm aus geblasenem Glas in Opalweiß. Stromkabel transparent, PVC-ummantelt, mit Drucktaste. Orientierbarer Lichtpunkt.



# FIFTY

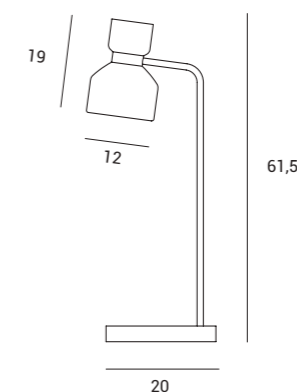

Source

E14

Power

1 x max 40w

1744.16



Lampada da terra con struttura in ottone spazzolato e diffusore in vetro soffiato bianco opale. Cavo elettrico rivestito con guaina in PVC colore trasparente con pulsante on/off. Punto luce orientabile.

Floor lamp with brushed brass body and opal white blown glass diffuser. Clear cables in PVC with on/off switch. Adjustable light source.

Stehleuchte mit Standfuß aus gebürstetem Messing und Leuchtschirm aus geblasenem Glas in Opalweiß. Stromkabel, transparent, PVC-ummantelt, mit Ein-/Aus-Taste. Orientierbarer Lichtpunkt.

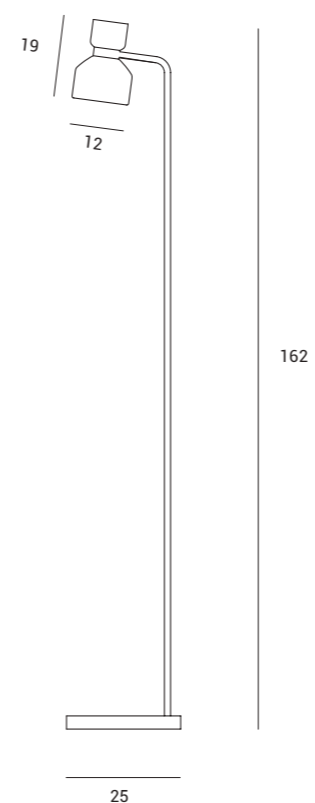

# FIFTY

1744.18



Source

E14

Power

1 x max 40w



Lampada sospensione.  
Diffusore in vetro trasparente  
fumè. Cavo di alimentazione  
trasparente cm 120.  
Rosone e portalamпада  
in ottone spazzolato.

Suspension lamp. Clear,  
smoke grey glass shade.  
120 cm clear cable. Canopy  
and lamp socket in brushed  
brass.

Pendelleuchte mit rauchfarbenem  
Leuchtschirm. Stromkabel  
transparent, 120 cm. Baldachin  
aus gebürstetem Messing.

# COCHI

1744.38

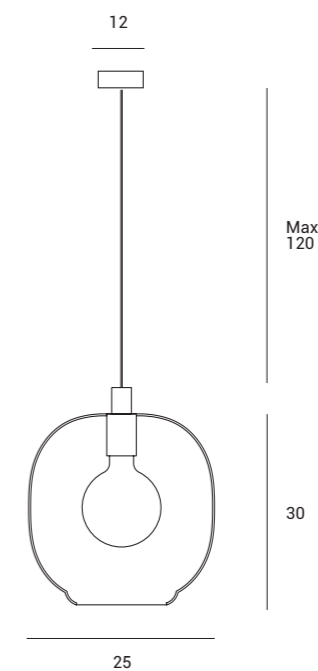

Source

E27

Power

1 x max 40w



Lampada a sospensione a 2 luci in vetro borosilicato color fumè. Rosone e portalam-pada in ottone spazzolato. Dotata di Kit di decentramento e cavi di alimentazione cm 120.

2-light pendant in smoke grey borosilicate glass. Canopy and lamp socket in brushed brass. Equipped with decentralisation kit and 120 cm cables.

Pendelleuchte mit 2 Leuchtschirmen aus rauchfarbenem Borosilikatglas. Baldachin und Fassung aus gebürstetem Messing. Set für dezentrale Montage und Stromkabel 120 cm.

1744.M.38



1744.38

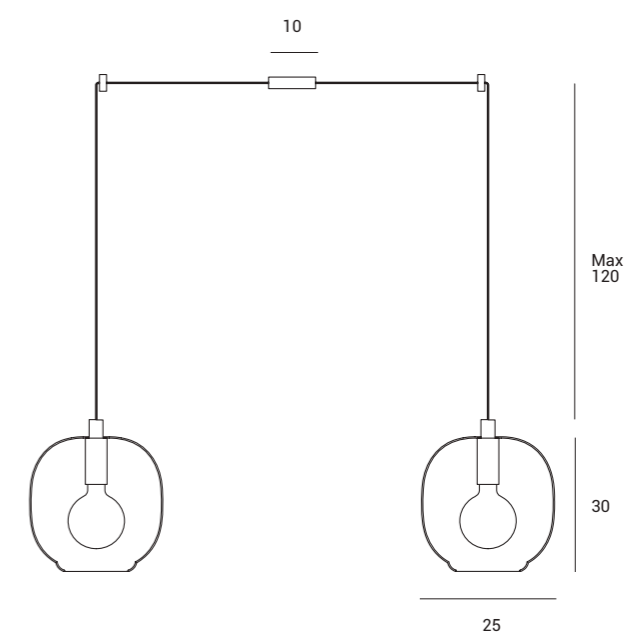

Source

E27

Power

2 x max 40w

COCHI

1 x 1744.M.38  
2 x 1744.38



Sospensione con diffusore in vetro trasparente. Cavo elettrico rivestito con guaina in tessuto nero di cm 120. Rosone verniciato nero diametro cm 8.

Pendant light with clear diffuser. 120 cm black fabric-covered power cable. Black painted canopy, diameter 8 cm.

Pendelleuchte mit transparentem Leuchtschirm. Stromkabel ummantelt mit schwarzem Textil, 120 cm. Baldachin schwarz lackiert mit Durchmesser 8 cm.

# EBE

1744.12

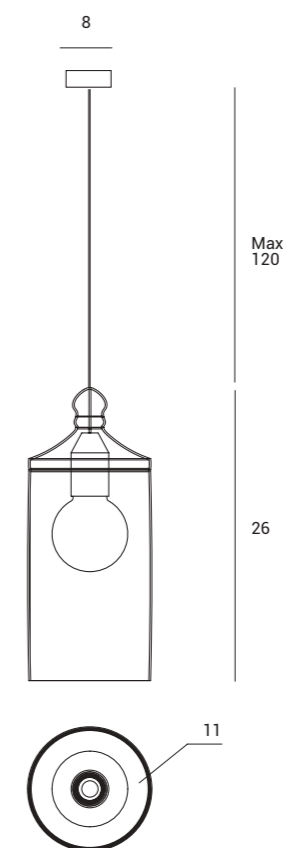

Source

E27

Power

1 x max 40w



Sospensione con diffusore in vetro fumé grigio. Cavo elettrico rivestito con guaina in tessuto nero di cm 120. Rosone verniciato nero diametro cm 8.

Pendant light with smoke grey diffuser. 120 cm black fabric-covered power cable. Black painted canopy, diameter 8 cm.

Pendelleuchte mit rauchfarbenem Leuchtschirm. Stromkabel ummantelt mit schwarzem Textil, 120 cm. Baldachin schwarz lackiert mit Durchmesser 8 cm.



EBE

1744.13

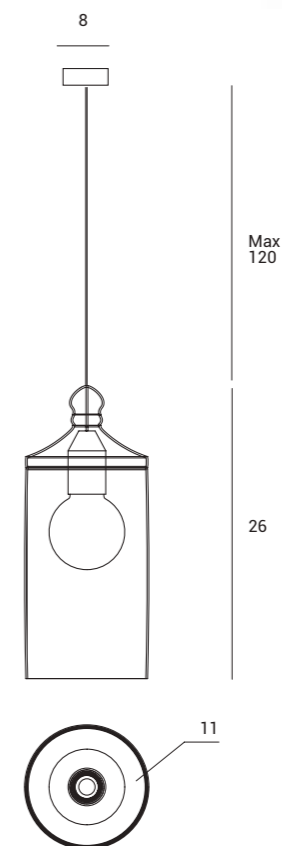

Source

E27

Power

1 x max 40w





Sospensione con diffusore  
in vetro trasparente.  
Cavo elettrico rivestito  
con guaina in tessuto nero  
di cm 120. Rosone verniciato  
nero diametro cm 12.

Pendant light with clear  
glass diffuser. 120 cm  
black fabric-covered  
power cable. Black  
painted canopy, diameter 12  
cm.

Pendelleuchte mit  
transparentem  
Leuchtschirm. Stromkabel  
ummantelt mit schwarzem  
Textil, 120 cm. Baldachin  
schwarz lackiert mit  
Durchmesser 12 cm.



# ADONE

1744.14

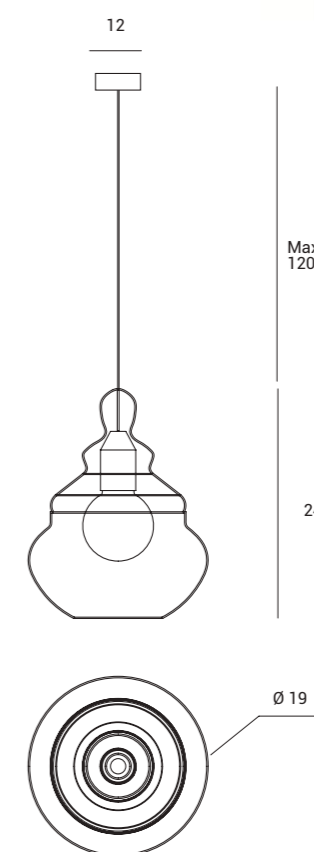

Source

E27

Power

1 x max 40w



Sospensione con diffusore in vetro color miele. Cavo elettrico rivestito con guaina in tessuto nero di cm 120. Rosone verniciato nero diametro cm 12.

Pendant light with honey-coloured glass diffuser. 120 cm black fabric-covered power cable. Black painted canopy, diameter 12 cm.

Pendelleuchte mit Leuchtschirm aus honigfarbenem Glas. Stromkabel ummantelt mit schwarzem Textil, 120 cm. Baldachin schwarz lackiert, mit Durchmesser 12 cm.

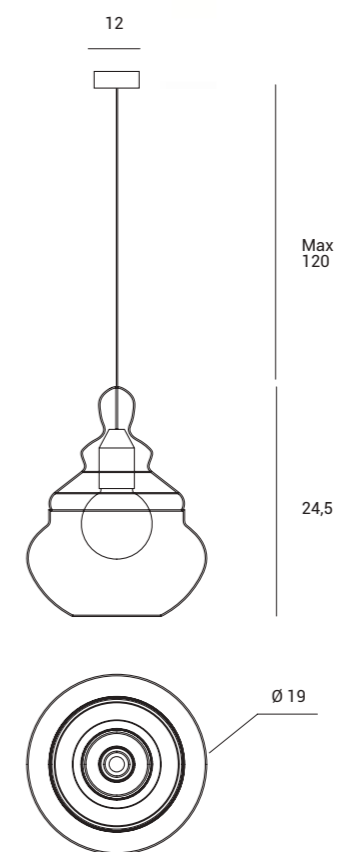

# ADONE

1744.15



Source

E27

Power

1 x max 40w



Lampada a sospensione  
a 4 luci con diffusori in  
vetro fumé, miele e tra-  
sparente. Cavo elettrico  
rivestito con guaina in  
tessuto nero di cm 120.

Four lights pendant with  
glass diffusers in smoke  
grey, honey and clear  
finish. Fabric cables in  
black finish cm 120.

Pendelleuchte mit 4  
Leuchtschirmen aus  
rauchfarbenem,  
honigfarbenem und  
transparentem Glas.  
Stromkabel ummantelt  
mit schwarzem Textil,  
120 cm.



1744.M.40



1744.12

1744.14

1744.13

1744.15

## EBE+ADONE

1 x 1744.M.40  
1 x 1744.12  
1 x 1744.13  
1 x 1744.14  
1 x 1744.15

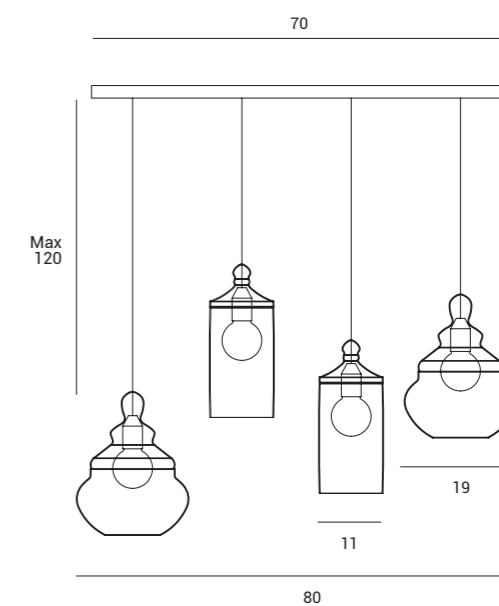

Source

E27

Power

4 x max 40w





Lampada sospensione con particolari verniciati nero. Diffusore in vetro soffiato bianco opale. Cavo di alimentazione trasparente cm 120.

Pendant light with black painted details. Opal white blown glass diffuser. Clear cable cm 120.

Pendelleuchte mit Kugelglas und schwarz lackierten Details. Leuchtschirm aus geblasenem Glas in Opalweiß. Stromkabel transparent, 120 cm.

# BOMBO

1744.34

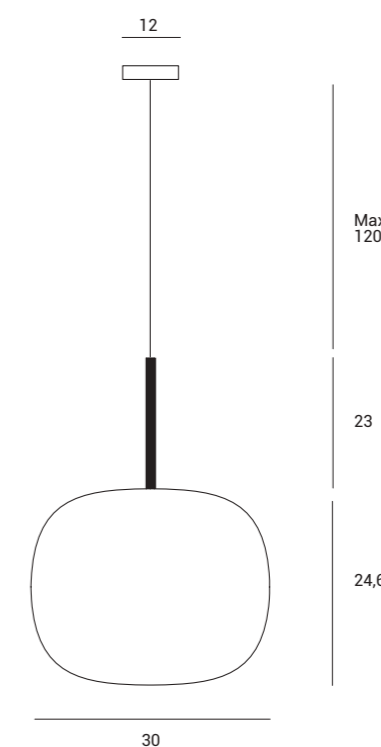

Source

E27

Power

1 x max 40w



Sospensione a 2 luci  
con particolari verniciati  
nero. Diffusore in vetro  
soffiato bianco opale.  
Dotata di Kit di decentramento  
e cavi di alimentazione  
trasparenti cm 120.

2-light pendant in opal white  
with black painted details.  
Opal white blown glass diffuser.  
Equipped with decentralisation  
kit and 120 cm clear cables.

Pendelleuchte mit 2  
Kugelgläsern aus geblasenem  
Glas in Opalweiß und schwarz  
lackierten Details. Set für  
dezentrale Montage. Stromkabel  
transparent, 120 cm.

# BOMBO

1 x 1744.M.51  
2 x 1744.34

1744.M.51



1744.34

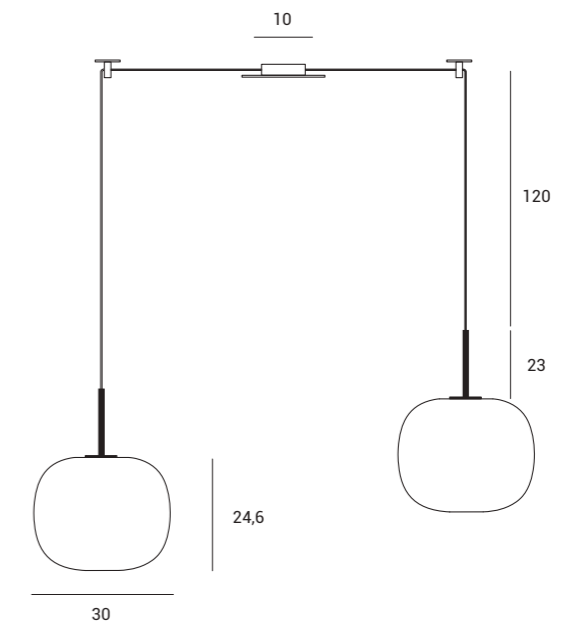

Source

E27

Power

2 x max 40w



Lampada da soffitto  
in vetro soffiato bianco  
latte diametro cm 19.  
Montatura in metallo  
verniciato nero.

Ceiling light in milky white  
blown glass, measuring  
19 cm in diameter.  
Black painted body.

Deckenleuchte aus  
geblasenem Glas in  
Milchweiß, Durchmesser  
19 cm. Halterung aus  
Metall, schwarz lackiert.

# BOMBO

1744.124

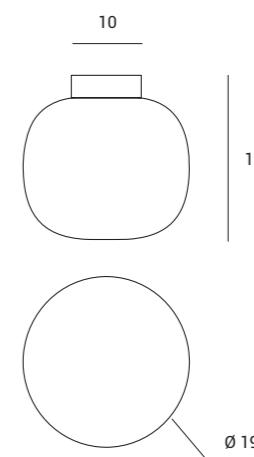

Source

E27

Power

1 x max 40w



Lampada da soffitto  
in vetro soffiato bianco  
latte diametro cm 30.  
Montatura in metallo  
verniciato nero.

Ceiling light in milky  
white blown glass,  
measuring 30 cm in  
diameter. Black  
painted body.

Deckenleuchte aus  
geblasenem Glas in  
Milchweiß, Durchmesser  
30 cm. Halterung aus  
Metall, schwarz lackiert.



# BOMBO

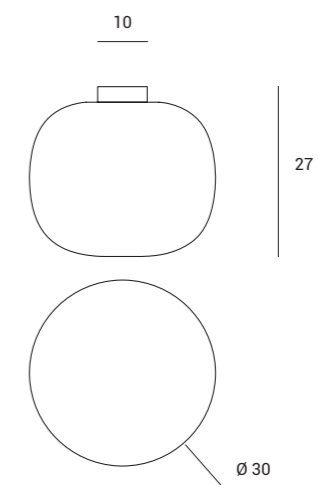

Source

E27

Power

1 x max 40w

1744.125

Lampada da tavolo  
in vetro soffiato bianco  
latte diametro cm 15.  
Montatura verniciata nero  
Cavo di alimentazione  
trasparente con dimmer.

Table lamp in milky white  
blown glass, measuring  
15 cm in diameter.  
Black painted body.  
Clear cable with dimmer  
switch.

Tischleuchte mit Leuchtschirm  
aus geblasenem Glas in  
Milchweiß, Durchmesser 15  
cm. Standfuß schwarz lackiert.  
Stromkabel transparent mit  
Dimmer.



# BOMBO

1744.126

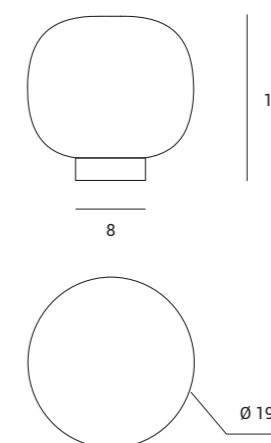

Source

E27

Dimmer

Power

1 x max 40w

Lampada da tavolo  
in vetro soffiato bianco  
latte diametro cm 30.  
Montatura verniciata  
nero Cavo di alimentazione  
trasparente con dimmer.

Table lamp in milky white  
blown glass, measuring  
30 cm in diameter. Black  
painted body. Clear cable  
with dimmer switch.

Tischleuchte mit Leuchtschirm  
aus geblasenem Glas in  
Milchweiß, Durchmesser 30 cm.  
Standfuß schwarz lackiert.  
Stromkabel transparent mit  
Dimmer



# BOMBO

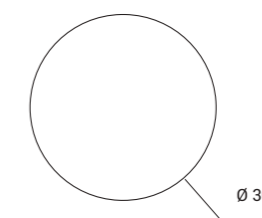
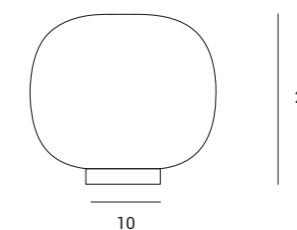

Source

E27

Dimmer

Power

1 x max 40w

1744.127







Lampada da parete  
in metallo verniciato  
nero. Diffusore in vetro  
soffiato bianco opale.

Wall light with black  
finish metal base.  
Opal white blown  
glass diffuser.

Wandleuchte mit  
Halterung aus  
schwarzem,  
pulverbeschichtetem  
Metall. Kugelglas aus  
geblasenem Glas  
in Opalweiß.



# BOMBO

1744.35

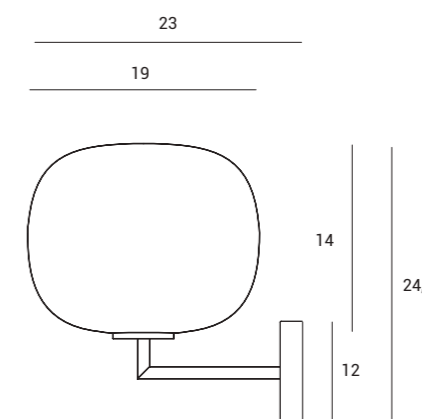

Source

E27

Power

1 x max 40w



Lampada da terra in metallo verniciato nero. Diffusore in vetro soffiato bianco opale. Cavo di alimentazione trasparente. Dotata di dimmer a piede.

Floor lamp with black finish body. Opal white blown glass diffuser. Clear cable. Equipped with foot-operated dimmer switch.

Stehleuchte mit Standfuß aus schwarzem, pulverbeschichtetem Metall. Leuchtschirm aus geblasenem Glas in Opalweiß. Stromkabel transparent. Inkl. Dimmer mit Fußschalter.

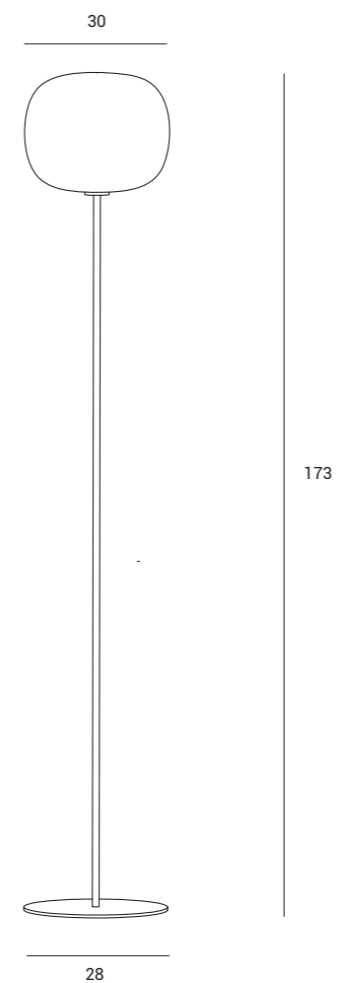

# BOMBO

1744.37



Source

E27

Dimmer

Power

1 x max 40w



Lampada da tavolo con base in marmo. Diffusore in vetro soffiato bianco opale. Cavo di alimentazione trasparente dotato di dimmer.

Table lamp with marble base. Opal white blown glass diffuser. Clear cable with dimmer switch.

Tischleuchte mit Marmorsockel. Leuchtschirm aus geblasenem Glas in Opalweiß. Stromkabel, transparent mit Dimmer.



# BOMBO

1744.36

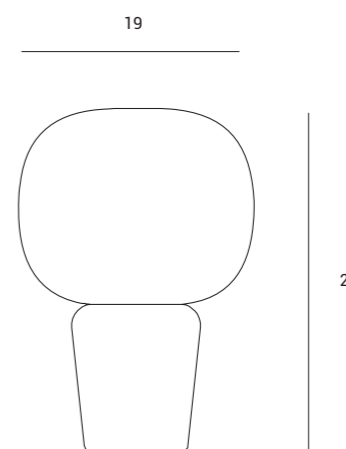

Source

E27

Dimmer

Power

1 x max 40w



Lampada a sospensione  
in metallo verniciato a  
polvere: colore esterno  
verde chiaro, interno  
bianco, diametro 19 cm.  
Rosone in ottone spazzo-  
lato e cavo di alimentazio-  
ne altezza 120 cm.

Pendant light in powder  
coated metal: light green  
finish on the outside, white  
on the inside, measuring  
19 cm in diameter.  
Canopy in brushed brass  
stem and 120 cm cables.

Pendelleuchte aus  
pulverbeschichtetem  
Metall, außen Hellgrün,  
innen Weiß, Durchmesser  
19 cm. Baldachin aus  
gebürstetem Messing.  
Stromkabel 120 cm.

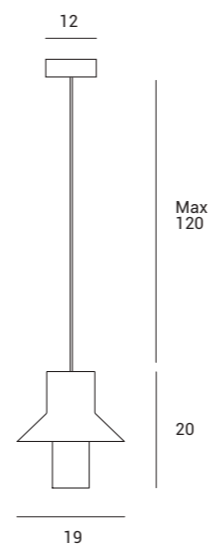

# LOLLIPOP

1744.156



Source

E27

Power

1 x max 40w

Lampada a sospensione  
in metallo verniciato a  
polvere: colore esterno lilla,  
interno bianco, diametro  
17,5 cm. Rosone in ottone  
spazzolato e cavo di  
alimentazione altezza  
120 cm.

Pendant light in powder  
coated metal: lilla finish on  
the outside, white on the  
inside, measuring 17,5 cm in  
diameter. Canopy in brushed  
brass stem and 120 cm  
cables.

Pendelleuchte aus  
pulverbeschichtetem Metall,  
außen Lila, innen Weiß,  
Durchmesser 17,5 cm.  
Baldachin aus gebürstetem  
Messing. Stromkabel 120 cm.

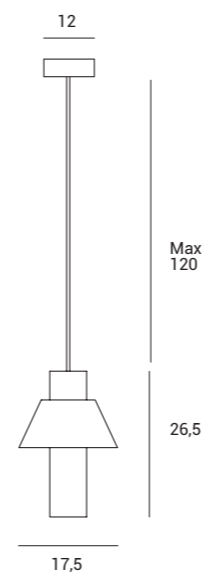

# LOLLIPOP

1744.157



Source

E27

Power

1 x max 40w





Lampada a sospensione  
in metallo verniciato a  
polvere: colore esterno oro  
spazzolato interno bianco,  
diametro 26 cm. Rosone in  
ottone spazzolato e cavo di  
alimentazione altezza 120 cm.

Pendant light in powder coated  
metal: brushed gold finish on  
the outside, white on the inside,  
measuring 26 cm in diameter.  
Canopy in brushed brass stem  
and 120 cm cables.

Pendelleuchte aus  
pulverbeschichtetem Metall,  
außen goldfarben, innen Weiß,  
Durchmesser 26 cm. Baldachin  
aus gebürstetem Messing.  
Stromkabel 120 cm.

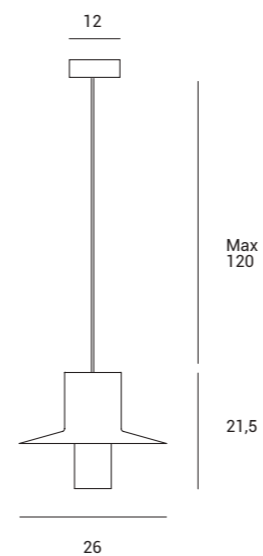

# LOLLIPOP

1744.158



Source

E27

Power

1 x max 40w



Lampada a sospensione a 3 luci in metallo verniciato a polvere: colori verde chiaro, lilla e oro spazzolato, interno bianco. Rosone in ottone spazzolato. Dotata di Kit di decentramento e cavi di alimentazione altezza 120 cm.

È possibile configurare una sospensione mixando le lampade della serie Lollipop (1744.156; 1744.157; 1744.158) a fianco un esempio.

3-light pendant in powder coated metal: light green, lilac and brushed gold colours, with white inside. Canopy in brushed brass. Equipped with decentralisation kit and 120 cm power supply cables.

You can customize your suspensions by mixing your lollipop lamps (1744.156; 1744.157; 1744.158) here an example

Pendelleuchte mit 3 Leuchtschirmen aus pulverbeschichtetem Metall. Farben: Hellgrün, Lila, Gold und innen Weiß. Baldachin aus gebürstetem Messing. Set für dezentrale Montage und Stromkabel 120 cm.

Es ist möglich, eine Aufhängung zu konfigurieren, indem die Lampen der Lollipop-Serie (1744.156; 1744.157; 1744.158) neben einem Beispiel gemischt werden.

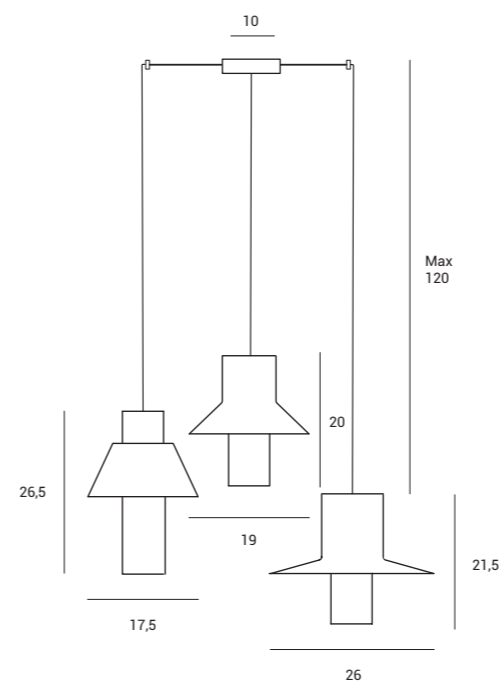

1744.M.50



# LOLLIPOP

1 x 1744.M.50  
1 x 1744.156  
1 x 1744.157  
1 x 1744.158



Source

E27

Power

3 x max 40w



Sospensione con diffusore in tessuto bianco. Filo metallico verniciato nero opaco. Cavo in tessuto bianco e grigio di cm 120.

Pendant light with white fabric diffuser. Metal body matt black painted. Black and grey finish fabric cable cm 120.

Pendelleuchte mit Leuchtschirm aus weißem Textil. Drahtrahmen in mattem Schwarz. Stromkabel ummantelt mit weißem Textil, 120 cm.

# NEW KENGO

1744.81

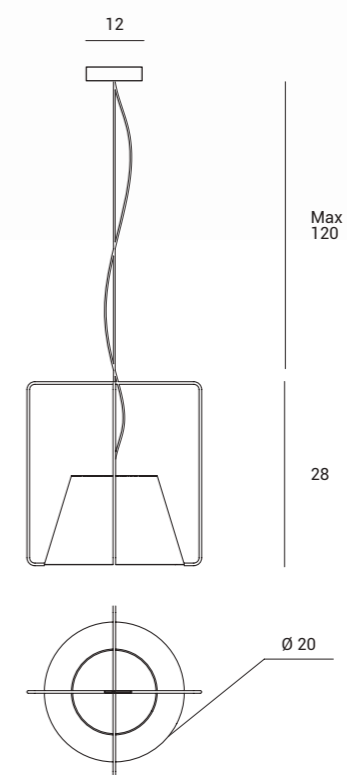

Source

E27

Power

1 x max 60w



Lampada da soffitto con diffusore in tessuto bianco. Filo metallico verniciato nero opaco.

Ceiling light with white fabric diffuser. Metal body matt black painted.

Deckenleuchte mit Leuchtschirm aus weißem Textil und Drahtrahmen in mattem Schwarz.

# NEW KENGO

1744.77

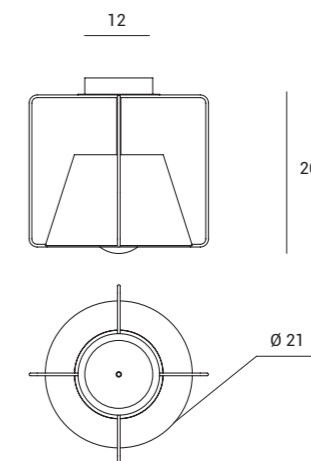

Source

E27

Power

1 x max 60w





Lampada da parete con diffusore in tessuto bianco. Filo metallico verniciato nero opaco

Wall light with white fabric diffuser. Metal body matt black painted.

Wandleuchte mit Leuchtschirm aus weißem Textil und Drahtrahmen in mattem Schwarz.



## NEW KENGO

1744.80

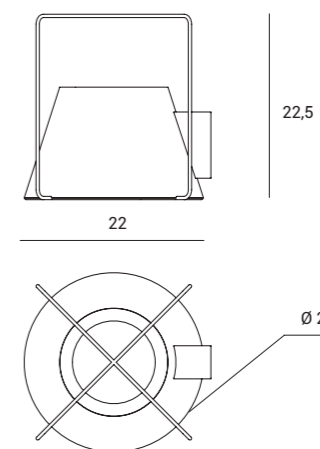

Source

E27

Power

1 x max 60w

Lampada da tavolo con diffusore in tessuto bianco. Filo metallico verniciato nero opaco. Cavo in tessuto bianco e grigio. Lampada dotata di dimmer.

Table lamp with white fabric diffuser. Metal body matt black painted. Black and grey finish fabric cable. Equipped with dimmer.

Tischleuchte mit Leuchtschirm aus weißem Textil. Drahtrahmen in mattem Schwarz. Lampe mit Dimmer ausgestattet.



# NEW KENGO

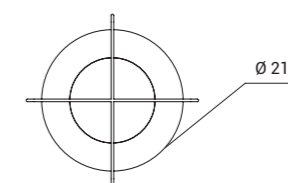
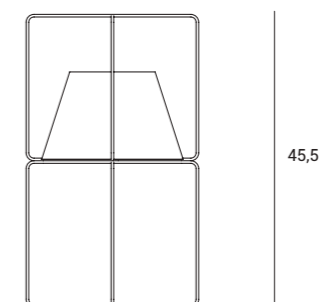

Source

E27

Power

Dimmer

1 x max 60w

1744.79



Lampada a sospensione  
in metallo verniciato a polvere:  
colore esterno nero soft touch,  
interno bianco, diametro 60 cm.  
Stelo in ottone spazzolato e cavi di  
alimentazione altezza 120 cm.

Pendant light in powder coated  
metal: soft touch black finish on  
the outside, white on the inside,  
measuring 60 cm in diameter.  
Brushed brass stem and 120 cm  
cables.

Pendelleuchte aus  
pulverbeschichtetem Metall.  
Außen Soft-Touch-Schwarz,  
innen Weiß, Durchmesser 60 cm.  
Pendelrohr aus gebürstetem  
Messing und Stromkabel 120 cm.

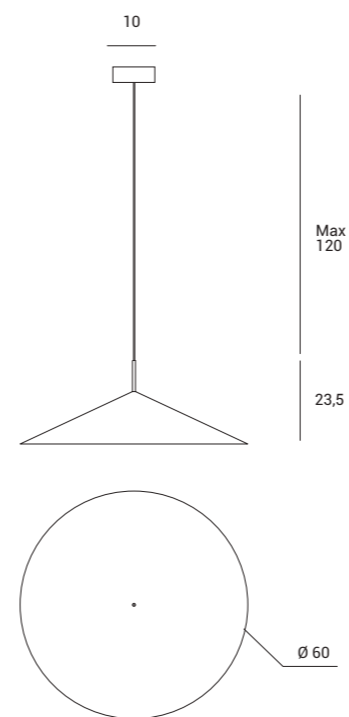

# SAMOI

1744.108

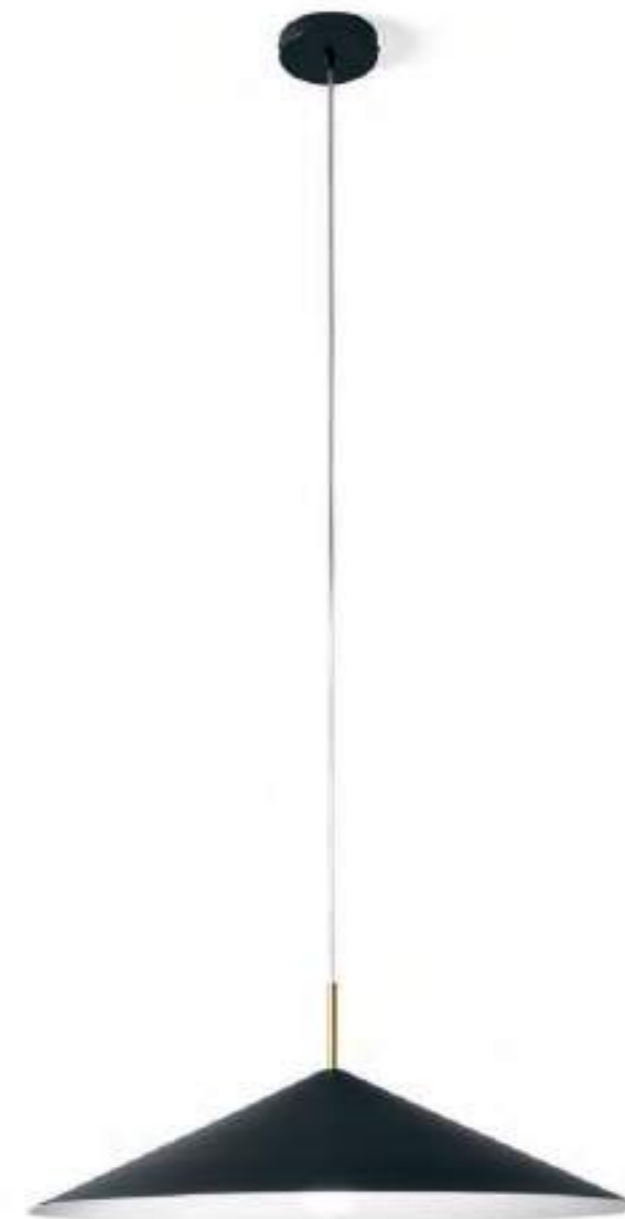

Source

E27

Power

1 x max 40w





Lampada a sospensione  
in metallo verniciato a polvere:  
colore esterno nero soft touch,  
interno bianco, diametro 26,5 cm.  
Stelo in ottone spazzolato e cavi di  
alimentazione altezza 120 cm.

Pendant light in powder coated  
metal: soft touch black finish on  
the outside, white on the inside,  
measuring 26.5 cm in diameter.  
Brushed brass stem and 120 cm  
cables.

Pendelleuchte aus  
pulverbeschichtetem Metall.  
Außen Soft-Touch-Schwarz,  
innen Weiß, Durchmesser 26,5 cm.  
Pendelrohr aus gebürstetem  
Messing und Stromkabel 120 cm.

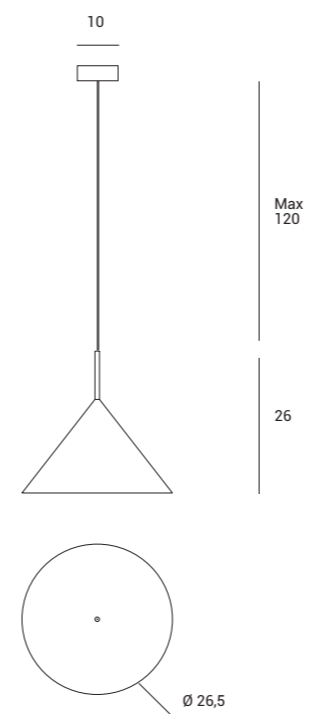

# SAMOI

1744.109



Source

E27

Power

1 x max 40w

Lampada a sospensione  
in metallo verniciato a  
polvere: colore esterno nero  
soft touch, interno bianco,  
diametro 20 cm. Stelo in  
ottone spazzolato e cavi di  
alimentazione altezza 120  
cm.

Pendant light in powder  
coated metal: soft touch  
black finish  
on the outside, white on the  
inside, measuring 20 cm in  
diameter. Brushed brass  
stem and 120 cm cables.

Pendelleuchte aus  
pulverbeschichtetem Metall.  
Außen Soft-Touch-Schwarz,  
innen Weiß, Durchmesser  
20 cm. Pendelrohr aus  
gebürstetem Messing und  
Stromkabel 120 cm.

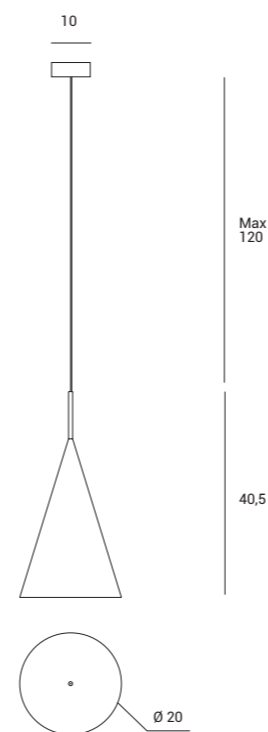

# SAMOI

1744.110



Source

E27

Power

1 x max 40w



Lampada a sospensione a 3 luci in metallo verniciato a polvere: colore esterno nero soft touch, interno bianco. Stelo in ottone spazzolato. Dotata di Kit di decentramento e cavi di alimentazione altezza 120 cm.

È possibile configurare una sospensione mixando le lampade della serie Samoi (1744.108; 1744.109; 1744.110) a fianco un esempio.

3-light pendant in powder coated metal: soft touch black finish on the outside, white on the inside. Brushed brass stem. Equipped with decentralisation kit and 120 cm cables.

You can customize your suspensions by mixing your Samoi lamps (1744.108; 1744.109; 1744.110) here an example

Pendelleuchte mit 3 Leuchtschirmen aus pulverbeschichtetem Metall. Außen Soft-Touch-Schwarz, innen Weiß. Pendelrohr aus gebürstetem Messing. Set für dezentrale Montage und Stromkabel 120 cm.

Es ist möglich, eine Aufhängung zu konfigurieren, indem die Lampen der Samoi-Serie (1744.108; 1744.109; 1744.110) neben einem Beispiel gemischt werden.

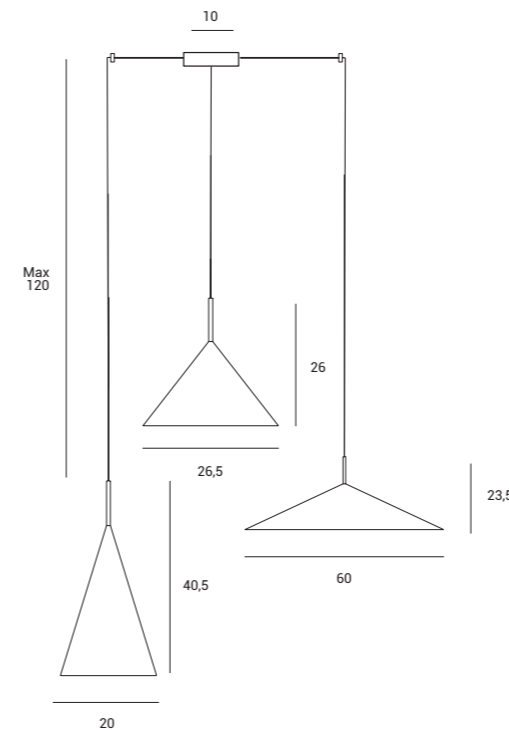

# SAMOI

- 1 x 1744.M.52
- 1 x 1744.108
- 1 x 1744.109
- 1 x 1744.110

1744.M.52

355



Source

E27

Power

3 x max 40w



Lampada da tavolo  
in vetro soffiato bianco  
latte diametro cm 15.  
Base in metallo cromato  
lucido diametro 8 cm.  
Dotata di pulsante on/off.

Table lamp in milky white  
blown glass, measuring 15 cm  
in diameter. Metal canopy with  
polished chrome finish,  
measuring 8 cm in diameter.  
Equipped with on/off switch.

Glaskugel-Tischleuchte  
in Milchweiß und aus Glas  
geblasen, Durchmesser 15 cm.  
Standfuß aus glänzendem  
Metall, Durchmesser 8 cm.  
Ausgestattet mit Ein/Aus-Taste.



# JUGEN CROMO

1744.210

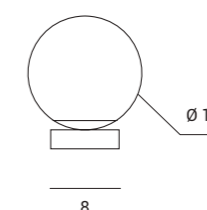

Source

E27

Power

1 x max 40w

Lampada da tavolo in vetro soffiato bianco latte diametro cm 20. Base in metallo cromato lucido diametro 12 cm. Dotata di pulsante on/off.

Table lamp in milky white blown glass, measuring 20 cm in diameter. Metal canopy with polished chrome finish, measuring 12 cm in diameter. Equipped with on/off switch.

Glaskugel-Tischleuchte in Milchweiß und aus Glas geblasen, Durchmesser 20 cm Standfuß aus glänzendem Metall, Durchmesser 12 cm. Ausgestattet mit Ein/Aus-Taste.



## JUGEN CROMO

1744.211

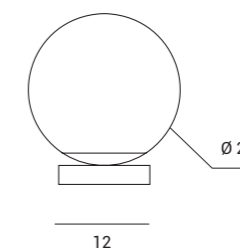

Source

E27

Power

1 x max 40w



Lampada da tavolo in vetro soffiato bianco latte diametro cm 25. Base in metallo cromato lucido diametro 12 cm. Dotata di pulsante on/off.

Table lamp in milky white blown glass, measuring 25 cm in diameter. Metal canopy with polished chrome finish, measuring 12 cm in diameter. Equipped with on/off switch.

Glaskugel-Tischleuchte in Milchweiß, aus Glas geblasen, Durchmesser 25 cm. Sockel aus glänzendem Metall, Durchmesser 12 cm. Ausgestattet mit Ein/Aus-Taste.



## JUGEN CROMO

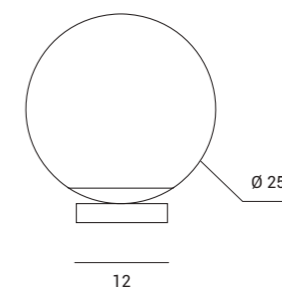

Source

E27

Power

1 x max 40w

1744.212



Sospensione in vetro soffiato  
bianco latte diametro cm 15.  
Rosone in metallo cromo  
lucido diametro 10 cm.  
Cavo di alimentazione  
altezza 120 cm.

Pendant light in milky white  
blown glass, measuring  
15 cm in diameter.  
Metal canopy with polished  
chrome finish, measuring 10  
cm in diameter, 120 cm cables.

Kugelpendelleuchte aus  
geblasenem Glas in Milchweiß,  
Durchmesser 15 cm. Baldachin  
aus verchromtem, glänzendem  
Metall, Durchmesser 10 cm.  
Stromkabel 120 cm.



## JUGEN CROMO

1744.83

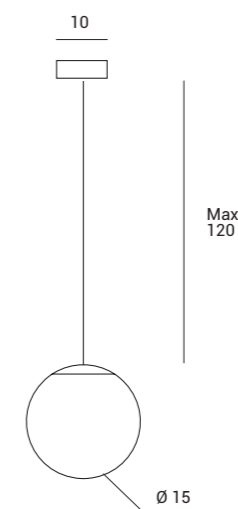

Source

E27

Power

1 x max 40w

Sospensione in vetro soffiato bianco latte diametro cm 20.  
Rosone in metallo cromo lucido diametro 10 cm. Cavo di alimentazione altezza 120 cm.

Pendant light in milky white blown glass, measuring 20 cm in diameter.  
Metal canopy with polished chrome finish, measuring 10 cm in diameter, 120 cm cables.

Kugelpendelleuchte aus geblasenem Glas in Milchweiß, Durchmesser 20 cm. Baldachin aus verchromtem, glänzendem Metall, Durchmesser 10 cm. Stromkabel 120 cm.



## JUGEN CROMO

1744.84

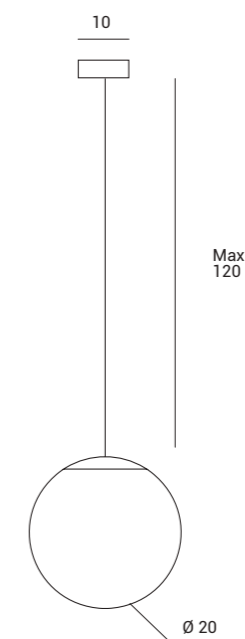

Source

E27

Power

1 x max 40w



Sospensione in vetro soffiato  
bianco latte diametro cm 25.  
Rosone in metallo cromo  
lucido diametro 10 cm.  
Cavo di alimentazione  
altezza 120 cm.

Pendant light in milky white  
blown glass, measuring 25 cm  
in diameter. Metal canopy with  
polished chrome finish, measur-  
ing 10 cm in diameter, 120 cm  
cables.

Kugelpendelleuchte aus  
geblasenem Glas in Milchweiß,  
Durchmesser 25 cm. Baldachin  
aus verchromtem, glänzendem  
Metall, Durchmesser 10 cm.  
Stromkabel 120 cm.

## JUGEN CROMO

1744.85



Source

E27

Power

1 x max 40w





Lampada da soffitto  
in vetro soffiato bianco latte  
diametro cm 15. Rosone in  
metallo cromo lucido diametro  
9 cm.

Ceiling light in milky white  
blown glass, measuring 15 cm  
in diameter. Metal canopy with  
polished chrome finish, measur-  
ing 9 cm in diameter.

Deckenleuchte aus  
geblasenem Glas in Milchweiß,  
Durchmesser 15 cm. Halterung  
aus verchromtem, glänzendem  
Metall, Durchmesser 9 cm.

# JUGEN CROMO

1744.74

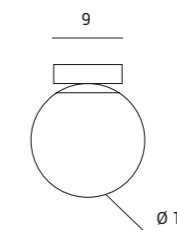

Source

E27

Power

1 x max 40w

Lampada da soffitto in vetro soffiato bianco latte diametro cm 20. Rosone in metallo cromo lucido diametro 12 cm.

Ceiling light in milky white blown glass, measuring 20 cm in diameter. Metal canopy with polished chrome finish, measuring 12 cm in diameter.

Deckenleuchte aus geblasenem Glas in Milchweiß, Durchmesser 20 cm. Halterung aus verchromtem, glänzendem Metall, Durchmesser 12 cm.



## JUGEN CROMO

1744.75

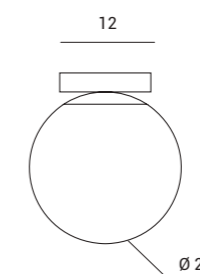

Source

E27

Power

1 x max 40w



Lampada da soffitto  
in vetro soffiato bianco latte  
diametro cm 25. Rosone in  
metallo cromo lucido diametro  
12 cm.

Ceiling light in milky white  
blown glass, measuring 25 cm  
in diameter. Metal canopy with  
polished chrome finish, measur-  
ing 12 cm in diameter.

Deckenleuchte aus  
geblasenem Glas in Milchweiß,  
Durchmesser 25 cm. Halterung  
aus verchromtem, glänzendem  
Metall, Durchmesser 12 cm.



## JUGEN CROMO

1744.76

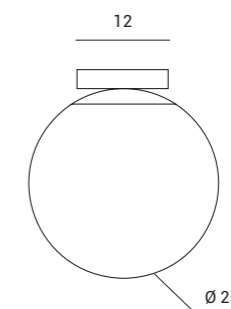

Source

E27

Power

1 x max 40w



miloox®

[www.miloox.com](http://www.miloox.com)  
[www.miloox.it](http://www.miloox.it)

LISTINO PREZZI  
PRICE LIST

//04

CODE	PRODUCT NAME	Price Euro incl VAT (22%)	Price Euro excl VAT	Bulb size Max size: Ø x H	EAN CODE	Pag.
------	--------------	------------------------------	------------------------	------------------------------	----------	------

1744.12	EBE	66,00	54,10	Ø102xH150mm	8050612940586	305
1744.13	EBE	69,00	56,56	Ø102xH150mm	8050612940593	307
1744.14	ADONE	74,00	60,66	Ø102xH150mm	8050612940609	309
1744.15	ADONE	78,00	63,93	Ø102xH150mm	8050612940616	311
1744.16	FIFTY	96,00	78,69	Ø110xH80mm	8050612940623	297
1744.17	FIFTY	68,00	55,74	Ø110xH80mm	8050612940630	295
1744.18	FIFTY	157,00	128,69	Ø110xH80mm	8050612940647	299
1744.19	FIFTY	70,00	57,38	Ø110xH80mm	8050612940654	291
1744.34	BOMBO	119,00	97,54	Ø65xH150mm	8050612942047	315
1744.35	BOMBO	99,00	81,15	Ø50xH100mm	8050612942054	327
1744.36	BOMBO	149,00	122,13	Ø50xH100mm	8050612942061	331
1744.37	BOMBO	248,00	203,28	Ø65xH150mm	8050612942078	329
1744.38	COCHI	119,00	97,54	Ø135xH200mm	8050612942382	301

CODE	PRODUCT NAME	Price Euro incl VAT (22%)	Price Euro excl VAT	Bulb size Max size: Ø x H	EAN CODE	Pag.
------	--------------	------------------------------	------------------------	------------------------------	----------	------

1744.62	JUGEN	325,00	266,39	Ø65xH240mm	8050612942580	263
1744.63	JUGEN	152,00	124,59	Ø50xH90mm	8050612942597	261
1744.64	JUGEN	198,00	162,30	Ø50xH140mm	8050612942603	249
1744.65	JUGEN	149,00	122,13	Ø50xH140mm	8050612942610	255
1744.66	JUGEN	154,00	126,23	Ø65xH190mm	8050612942627	251
1744.67	JUGEN	181,00	148,36	Ø65xH190mm	8050612942634	253
1744.68	JUGEN	336,00	275,41	Ø50xH140mm	8050612942641	247
1744.70	JUGEN	135,00	110,66	Ø65xH240mm	8050612942665	245
1744.71	JUGEN	347,00	284,43	Ø50xH140mm	8050612942672	265
1744.72	JUGEN	109,00	89,34	Ø50xH140mm	8050612942689	257
1744.73	JUGEN	125,00	102,46	Ø50xH90mm	8050612942696	259
1744.74	JUGEN	55,00	45,08	Ø50xH90mm	8050612943624	369
1744.75	JUGEN	62,00	50,82	Ø50xH140mm	8050612943631	371

CODE	PRODUCT NAME	Price Euro incl VAT (22%)	Price Euro excl VAT	Bulb size Max size: Ø x H	EAN CODE	Pag.
1744.76	JUGEN	77,00	63,11	Ø65xH190mm	8050612943648	373
1744.77	NEW KENGO	86,00	70,49	Ø60xH105mm	8050612943969	343
1744.79	NEW KENGO	91,00	74,59	Ø60xH105mm	8050612943983	347
1744.80	NEW KENGO	88,00	72,13	Ø60xH90mm	8050612943990	345
1744.81	NEW KENGO	86,00	70,49	Ø60xH105mm	8050612944003	341
1744.83	JUGEN CROMO	57,00	46,72	Ø50xH90mm	8050612944027	363
1744.84	JUGEN CROMO	65,00	53,28	Ø50xH140mm	8050612944034	365
1744.85	JUGEN CROMO	79,00	64,75	Ø65xH190mm	8050612944904	367
1744.88	X-RAY	168,00	137,70	Ø21xH80mm	8050612943778	183
1744.89	HAT	253,00	207,38	Ø65xH190mm	8050612943785	279
1744.90	X-RAY	179,00	146,72	Ø21xH80mm	8050612943792	187
1744.91	HAT	218,00	178,69	Ø65xH190mm	8050612943808	283 and 287
1744.92	HAT	193,00	158,20	Ø50xH90mm	8050612943815	289

CODE	PRODUCT NAME	Price Euro incl VAT (22%)	Price Euro excl VAT	Bulb size Max size: Ø x H	EAN CODE	Pag.
1744.93	HAT	165,00	135,25	Ø50xH90mm	8050612943822	280 and 285
1744.94	X-RAY	170,00	139,34	Ø21xH80mm	8050612943839	183
1744.95	X-RAY	182,00	149,18	Ø21xH80mm	8050612943846	187
1744.96	X-RAY	154,00	126,23	Ø21xH80mm	8050612943853	185
1744.97	X-RAY	152,00	124,59	Ø21xH80mm	8050612943860	185
1744.98	POMI'	289,00	236,89	Ø20xH60mm	8050612944065	123
1744.99	POMI'	206,00	168,85	Ø20xH60mm	8050612943877	133
1744.100	POMI'	317,00	259,84	Ø20xH60mm	8050612944072	135
1744.101	POMI'	344,00	281,97	Ø20xH60mm	8050612944089	127
1744.102	POMI'	374,00	306,56	Ø20xH60mm	8050612943884	125
1744.103	POMI'	176,00	144,26	Ø20xH60mm	8050612943891	137
1744.104	POMI'	98,00	80,33	Ø20xH60mm	8050612943907	129
1744.105	POMI'	121,00	99,18	Ø20xH60mm	8050612943914	131



CODE	PRODUCT NAME	Price Euro incl VAT (22%)	Price Euro excl VAT	Bulb size Max size: Ø x H	EAN CODE	Pag.
1744.108	SAMOI	207,00	169,67	Ø180xH200mm	8050612944119	349
1744.109	SAMOI	143,00	117,21	Ø80xH140mm	8050612944126	351
1744.110	SAMOI	138,00	113,11	Ø80xH200mm	8050612944133	353
1744.124	BOMBO	91,00	74,59	Ø50xH100mm	8050612943921	319
1744.125	BOMBO	110,00	90,16	Ø65xH150mm	8050612943938	321
1744.126	BOMBO	108,00	88,52	Ø50xH100mm	8050612943945	323
1744.127	BOMBO	127,00	104,10	Ø65xH150mm	8050612943952	325
1744.139	ALADINO	108,00	88,52	Ø20xH80mm	8050612944386	from 213 to 215
1744.141	ALADINO	262,00	214,75	Ø20xH80mm	8050612945154	from 216 to 221
1744.144	ALADINO	401,00	328,69	Ø20xH80mm	8050612944423	from 222 to 229
1744.149	ALADINO	707,00	579,51	Ø20xH80mm	8050612944478	from 230 to 237
1744.150	LUNAR	94,00	77,05	Ø20xH80mm	8050612944485	267
1744.151	LUNAR	124,00	101,64	Ø50xH140mm	8050612944492	269

CODE	PRODUCT NAME	Price Euro incl VAT (22%)	Price Euro excl VAT	Bulb size Max size: Ø x H	EAN CODE	Pag.
1744.152	LUNAR	181,00	148,36	Ø65xH240mm	8050612944508	271
1744.153	LUNAR	77,00	63,11	Ø20xH80mm	8050612944515	273
1744.154	LUNAR	103,00	84,43	Ø50xH140mm	8050612944522	275
1744.155	LUNAR	146,00	119,67	Ø65xH240mm	8050612944539	277
1744.156	LOLLIPOP	124,00	101,64	Ø60xH160mm	8050612945161	333
1744.157	LOLLIPOP	124,00	101,64	Ø60xH160mm	8050612945178	335
1744.158	LOLLIPOP	131,00	107,38	Ø60xH160mm	8050612945185	337
1744.164	COSMO	350,00	286,89	Ø20xH70mm	8050612945192	139
1744.165	COSMO	292,00	239,34	Ø20xH70mm	8050612945208	141
1744.166	COSMO	219,00	179,51	Ø20xH70mm	8050612945215	143
1744.167	COSMO	60,00	49,18	Ø20xH70mm	8050612945222	145 and 149
1744.168	COSMO	385,00	315,57	Ø20xH70mm	8050612945239	155
1744.169	COSMO	198,00	162,30	Ø20xH70mm	8050612945246	153

CODE	PRODUCT NAME	Price Euro incl VAT (22%)	Price Euro excl VAT	Bulb size Max size: Ø x H	EAN CODE	Pag.
1744.170	COSMO	106,00	86,89	Ø20xH70mm	8050612945253	147
1744.171	COSMO	132,00	108,20	Ø20xH70mm	8050612945260	151
1744.172	ALADINO	823,00	674,59	Ø20xH80mm	8050612945277	from 238 to 243
1744.174	BABELE	183,00	150,00	Ø80xH160mm	8050612944911	from 77 to 79
1744.175	MIKADO	136,00	111,48	Ø20xH60mm	8050612944928	from 7 to 11
1744.176	MIKADO	194,00	159,02	Ø20xH60mm	8050612944935	from 13 to 15
1744.177	MIKADO	251,00	205,74	Ø20xH60mm	8050612944942	from 17 to 21
1744.178	MIKADO	303,00	248,36	Ø20xH60mm	8050612946533	from 23 to 25
1744.179	MIKADO	110,00	90,16	Ø20xH60mm	8050612946540	27
1744.180	POT	101,00	82,79	Ø20xH60mm	8050612946557	from 85 to 87
1744.181	POT	204,00	167,21	Ø20xH60mm	8050612946564	from 89 to 91
1744.182	POT	242,00	198,36	Ø20xH60mm	8050612946571	from 93 to 95
1744.187	MOSE	108,00	88,52	Ø20xH60mm	8050612946687	from 53 to 55 and 74

CODE	PRODUCT NAME	Price Euro incl VAT (22%)	Price Euro excl VAT	Bulb size Max size: Ø x H	EAN CODE	Pag.
1744.188	MOSE	108,00	88,52	Ø20xH60mm	8050612946694	from 53 to 55 and 74
1744.189	MOSE	108,00	88,52	Ø20xH60mm	8050612946700	from 53 to 55 and 74
1744.190	MOSE	114,00	93,44	Ø20xH60mm	8050612946717	from 57 to 59 and 74
1744.191	MOSE	114,00	93,44	Ø20xH60mm	8050612946724	from 57 to 59 and 74
1744.192	MOSE	114,00	93,44	Ø20xH60mm	8050612946731	from 57 to 59 and 74
1744.193	MOSE	120,00	98,36	Ø20xH60mm	8050612946748	from 61 to 65 and 74
1744.194	MOSE	120,00	98,36	Ø20xH60mm	8050612946755	from 61 to 65 and 74
1744.195	MOSE	120,00	98,36	Ø20xH60mm	8050612946762	from 61 to 65 and 74
1744.196	MOSE	123,00	100,82	Ø20xH60mm	8050612946779	47
1744.197	MOSE	102,00	83,61	Ø20xH60mm	8050612946786	from 49 to 51
1744.198	JUGEN BLACK EDITION	292,00	239,34	Ø65xH240mm	8050612946793	163
1744.199	JUGEN BLACK EDITION	116,00	95,08	Ø50xH90mm	8050612946809	181
1744.200	JUGEN BLACK EDITION	176,00	144,26	Ø50xH140mm	8050612946816	165

CODE	PRODUCT NAME	Price Euro incl VAT (22%)	Price Euro excl VAT	Bulb size Max size: Ø x H	EAN CODE	Pag.
1744.201	JUGEN BLACK EDITION	124,00	101,64	Ø50xH140mm	8050612946823	175
1744.202	JUGEN BLACK EDITION	121,00	99,18	Ø65xH190mm	8050612946830	171
1744.203	JUGEN BLACK EDITION	157,00	128,69	Ø65xH190mm	8050612946847	173
1744.204	JUGEN BLACK EDITION	313,00	256,56	Ø50xH140mm	8050612946854	169
1744.205	JUGEN BLACK EDITION	115,00	94,26	Ø65xH240mm	8050612946861	157
1744.206	JUGEN BLACK EDITION	319,00	261,48	Ø50xH140mm	8050612946878	159
1744.207	JUGEN BLACK EDITION	88,00	72,13	Ø50xH140mm	8050612946885	177
1744.208	JUGEN BLACK EDITION	99,00	81,15	Ø50xH90mm	8050612946892	179
1744.209	ALBA	147,00	120,49	Ø90xH150mm	8050612946908	from 81 to 83
1744.210	JUGEN CROMO	99,50	81,56	Ø50xH90mm	8050612947394	357
1744.211	JUGEN CROMO	106,00	86,89	Ø50xH140mm	8050612947400	359
1744.212	JUGEN CROMO	120,00	98,36	Ø65xH190mm	8050612947417	361
1744.213	NEORETRO	93,00	76,23	Ø120xH100mm	8050612947424	from 97 to 101

CODE	PRODUCT NAME	Price Euro incl VAT (22%)	Price Euro excl VAT	Bulb size Max size: Ø x H	EAN CODE	Pag.
1744.214	NEORETRO	144,00	118,03	Ø120xH100mm	8050612947431	from 103 to 107
1744.215	NEORETRO	213,00	174,59	Ø120xH100mm	8050612947448	from 109 to 113
1744.216	NEORETRO	231,00	189,34	Ø120xH100mm	8050612947455	from 115 to 117
1744.217	NEORETRO	291,00	238,52	Ø120xH100mm	8050612947462	from 119 to 121
1744.218	MIKADO TRANSPARENT	136,00	111,48	Ø20xH60mm	8050612947479	from 29 to 31
1744.219	MIKADO TRANSPARENT	194,00	159,02	Ø20xH60mm	8050612947486	from 33 to 37
1744.220	MIKADO TRANSPARENT	257,00	210,66	Ø20xH60mm	8050612947493	from 39 to 41
1744.221	MIKADO TRANSPARENT	304,00	249,18	Ø20xH60mm	8050612947509	43
1744.222	MIKADO TRANSPARENT	110,00	90,16	Ø20xH60mm	8050612947516	45
1744.M.38	COCHI	88,00	72,13		8050612947523	303
1744.M.40	EBE+ADONE	110,00	90,16		8050612947530	313
1744.M.47	FIFTY	72,00	59,02		8050612947547	293
1744.M.50	LOLLIPOP	99,00	81,15		8050612947554	339



CODE	PRODUCT NAME	Price Euro incl VAT (22%)	Price Euro excl VAT	Bulb size Max size: Ø x H	EAN CODE	Pag.
1744.M.51	BOMBO	61,00	50,00		8050612947561	317
1744.M.52	SAMOI	99,00	81,15		8050612947578	355
1744.M.128	X-RAY	75,00	61,48	Ø21xH80mm	8050612944638	from 210 to 211
1744.M.131	X-RAY	217,00	177,87	Ø21xH80mm	8050612944645	195
1744.M.132	X-RAY	302,00	247,54	Ø21xH80mm	8050612944652	195
1744.M.133	X-RAY	662,00	542,62	Ø21xH80mm	8050612944669	195
1744.M.134	X-RAY	120,00	98,36	Ø21xH80mm	8050612944676	from 210 to 211
1744.M.135	X-RAY	120,00	98,36	Ø21xH80mm	8050612944683	from 210 to 211
1744.M.136	X-RAY	120,00	98,36	Ø21xH80mm	8050612944690	from 210 to 211
1744.M.183	MOSE	14,00	11,48	Ø20xH60mm	8050612946649	75
1744.M.184	MOSE	129,00	105,74	Ø20xH60mm	8050612946656	75
1744.M.185	MOSE	180,00	147,54	Ø20xH60mm	8050612946663	75
1744.M.186	MOSE	237,00	194,26	Ø20xH60mm	8050612946670	75

CODE	PRODUCT NAME	Price Euro incl VAT (22%)	Price Euro excl VAT	Bulb size Max size: Ø x H	EAN CODE	Pag.
1744.V.118	X-RAY	93,00	76,23	Ø21xH80mm	8050612944706	from 210 to 211
1744.V.119	X-RAY	90,00	73,77	Ø21xH80mm	8050612944713	from 210 to 211
1744.V.120	X-RAY	83,00	68,03	Ø21xH80mm	8050612944720	from 210 to 211
1744.V.128	X-RAY	92,00	75,41	Ø21xH80mm	8050612944737	from 210 to 211
1744.V.129	X-RAY	96,00	78,69	Ø21xH80mm	8050612944744	from 210 to 211
1744.V.130	X-RAY	86,00	70,49	Ø21xH80mm	8050612944751	from 210 to 211

LISTINO PREZZI  
PEZZI VETRI DI RICAMBIO

GLASS SPARE PARTS  
PRICE LIST

CODE	PRODUCT NAME		Price Euro incl VAT (22%)	Price Euro excl VAT	Pag.
1744.V.12	Vetro Ebe trasparente	Transparent Ebe glass	49,00	40,16	305
1744.V.13	Vetro Ebe grigio	Grey Ebe glass	49,00	40,16	307
1744.V.14	Vetro Adone trasparente	Transparent Adone glass	49,00	40,16	309
1744.V.15	Vetro Adone miele	Honey Adone glass	49,00	40,16	311
1744.V.16	Vetro Fifty piccolo completo	Small complete fifty glass	35,00	28,69	297
1744.V.19	Vetro Fifty grande completo	Big complete fifty glass	39,00	31,97	291
1744.V.34	Vetro Bombo grande	Big Bombo glass	62,50	51,23	315
1744.V.35	Vetro Bombo piccolo	Small Bombo glass	30,00	24,59	327
1744.V.38	Vetro Cochi	Cochi glass	61,00	50,00	301
1744.V.62	Vetro Jugen/Lunar diam.30	Jugen/Lunar glass diam. 30	59,00	48,36	263
1744.V.63	Vetro Jugen/Hat diam.15	Jugen/Hat glass diam. 15	20,00	16,39	261
1744.V.64	Vetro Jugen/Lunar diam.20	Jugen/Lunar diam. 20	31,50	25,82	249
1744.V.66	Vetro Jugen/Hat diam.25	Jugen/Hat glass diam. 25	44,50	36,48	251
1744.V.98	Vetro Pomi' diam.10	Pomi' glass diam. 10	10,00	8,20	123
1744.V.128.INT.SAT	Vetro interno satinato	Satin internal glass	15,00	12,30	195
1744.V.129.INT.SAT	Vetro interno satinato	Satin internal glass	15,00	12,30	195
1744.V.130.INT.SAT	Vetro interno satinato	Satin internal glass	15,00	12,30	195
1744.V.139	Vetro Aladino diam.15	Aladino glass diam. 15	26,00	21,31	213
1744.V.150	Vetro Lunar diam.20	Lunar glass diam. 20	15,00	12,30	267
1744.V.156	Vetro Lollipop	Lollipop glass	12,50	10,25	333
1744.V.164	Vetro Cosmo/Mikado trasparente	Cosmo/Mikado transparent glass	17,50	14,34	139
1744.V.174	Vetro Babele	Babele glass	30,00	24,59	77
1744.V.175	Vetro Mikado/Pot opale	Mikado/Pot opal glass	18,00	14,75	7
1744.V.187	Vetro Mose	Mose glass	18,00	14,75	53
1744.V.209	Vetro Alba	Alba glass	25,00	20,49	81
1744.V.213	Vetro Neoretro	Neoretro glass	25,00	20,49	97





**AD**

Davide Negri Studio

**Graphic**

Red Apple International

**Photo**

Paolo Volontè