

 **TRIO**  
LIGHTING FOR YOU



OUTDOOR

2021

---

AUSSENLEUCHTEN  
OUTDOOR LUMINAIRES



Sobald die Sonne untergeht, darf eine innovative Außenbeleuchtung nicht fehlen. Ein gut beleuchteter Außenbereich bietet nicht nur Sicherheit, sondern dient der Orientierung und schafft Atmosphäre rund um Ihr zu Hause. Außenleuchten sollten hohe Qualitätsanforderungen erfüllen, um den unterschiedlichen Bedingungen wie Feuchtigkeit, Regen, Schnee sowie jahreszeitlich bedingten Temperaturschwankungen unbeschadet standzuhalten. Unsere Außenleuchten werden in hochwertigem Aluminium-Druckguss gefertigt und versprechen Betriebssicherheit während der gesamten Lebensdauer, bei jeder Witterung, 365 Tage im Jahr. Moderne LED-Technologie sorgt darüber hinaus für gute Beleuchtungsqualität und hohe Energieeffizienz.

Wir wünschen Ihnen viel Freude mit unser neuen Outdoor-Kollektion.

As soon as the sun goes down innovative outside lighting is a must. Well lit outdoor areas do not only provide security, but are an orientation guide and create atmosphere around your home. Outdoor lighting should fulfil high quality standards to withstand diverse conditions such as dampness, rain, snow and seasonal variations in temperature. Our outdoor lamps are produced in high-quality diecast aluminium and promise operational reliability for their entire life cycle, in all weathers, 365 days a year. Modern LED technology also provides a high level of both light quality and power efficiency. We hope you enjoy our new outdoor collection.

Dès que le soleil se couche, un éclairage extérieur innovant est indispensable. Un espace extérieur bien éclairé offre non seulement la sécurité, mais vous aide aussi à vous orienter et crée une agréable ambiance autour de votre maison. Les luminaires extérieurs doivent répondre à des exigences de qualité élevées afin de résister sans dommage aux aléas climatiques telles que l'humidité, la pluie, la neige et les variations saisonnières de température. Nos luminaires d'extérieur sont fabriqués en aluminium moulé sous pression de haute qualité et garantissent une sécurité de fonctionnement pendant toute leur durée de vie, par tous les temps, 365 jours par an. La technologie LED moderne assure en outre une bonne qualité d'éclairage et une haute efficacité énergétique. Nous vous souhaitons beaucoup de satisfaction avec notre nouvelle collection d'extérieur.

Zodra de zon ondergaat, mag een innovatieve buitenverlichting niet ontbreken. Een goed verlichte buitenzone biedt niet alleen veiligheid, maar is goed voor de oriëntatie en scheidt sfeer rond uw huis. Buitenlichten moeten voldoen aan hoge kwaliteitsvereisten om bestand te zijn tegen diverse omstandigheden zoals vocht, regen, sneeuw alsook van het seizoen afhankende temperatuurschommelingen. Onze buitenlichten worden uit hoogwaardig aluminium gegoten en beloven een veilige werking tijdens hun volledige levensduur, bij alle weersomstandigheden, 365 dagen per jaar. Moderne ledtechnologie zorgt daarnaast voor een goede verlichtingskwaliteit en hoge energie-efficiëntie. We wensen u veel plezier met onze nieuwe collectie voor buiten.

Tan pronto como se pone el sol, no debe faltar una iluminación exterior innovadora. Una zona exterior bien iluminada no solo ofrece seguridad, sino que también sirve para orientarse y crear una atmósfera alrededor de tu casa. La iluminación exterior debe cumplir unos altos requisitos de calidad para soportar las diferentes condiciones de humedad, lluvia y nieve, así como las condiciones estacionales de oscilación de temperaturas. Nuestra iluminación exterior está fabricada en aluminio fundido a presión de alta calidad y aseguran la seguridad operativa durante toda su vida, en cualquier clima, 365 días al año. La moderna tecnología LED proporciona también una iluminación de buena calidad y una gran eficiencia energética. Le deseamos una gran satisfacción con nuestra nueva colección de exterior.

Non appena il sole tramonta, l'illuminazione esterna innovativa è un must. Un'area esterna ben illuminata non solo garantisce la sicurezza ma funge anche da mezzo di orientamento e crea una piacevole atmosfera intorno alla vostra casa. Le lampade per esterni devono soddisfare elevati requisiti in termini di qualità per resistere, senza subire danni, alle varie condizioni climatiche come umidità, pioggia, neve e fluttuazioni stagionali della temperatura. Le nostre lampade per esterni sono prodotte in alluminio pressofuso di alta qualità e garantiscono affidabilità operativa durante tutto il loro ciclo di vita, in qualsiasi condizione atmosferica, 365 giorni all'anno. La moderna tecnologia LED garantisce inoltre una buona qualità dell'illuminazione e un'elevata efficienza energetica. Vi auguriamo il massimo del piacere con la nostra nuova Collezione Outdoor.

De îndată ce soarele apune, un sistem inovator de iluminat exterior nu trebuie să lipsească. Un spațiu exterior bine iluminat nu oferă numai securitate, ci are și rolul de a asigura orientarea și de a crea o atmosferă plăcută în jurul casei. Lămpile exterioare trebuie să îndeplinească cerințe înalte de calitate, pentru a rezista fără deteriorări la acțiunea diferitelor condiții de mediu, precum umiditatea, ploaia, ninsoarea, precum și fluctuațiile sezoniere de temperatură. Lămpile noastre exterioare sunt produse din aluminiu turnat sub presiune și garantează siguranța în operare pe parcursul întregii durate de exploatare, în orice condiții meteo, timp de 365 de zile pe an. Tehnologia LED modernă asigură suplimentar o calitate bună a iluminatului și o eficiență energetică înaltă. Vă dorim să vă bucurați de colecția noastră outdoor.

Kun aurinko laskee, ei innovatiiviseen ulkovalaistukseen pitäisi tarvita puuttua. Hyvin valaistu ulkoalue tarjoaa turvallisuuden lisäksi myös kulkureittien ohjausta ja luo tunnelmaa kodin ympärille. Ulkovalaisimien on täytettävä korkeat laatuvaatimukset, jotta ne kestävät erilaisia olosuhteita, kuten kosteutta, sadetta, lunta ja vuodenaikojen lämpötilanvaihteluita ilman vaurioita. Ulkovalaisimet valmistetaan korkealaatuisesta painealletusta alumiinista, ja ne takaavat varman toiminnan koko käyttöikänsä ajan säästä riippumatta, 365 päivää vuodessa. Moderni LED-tekniikka varmistaa myös hyvän valaistuksen laadun ja korkean energiatehokkuuden. Toivomme, että uusi ulkovalaisinmallistomme tuottaa sinulle paljon iloa.

Gdy tylko zachodzi słońce, nie powinno zabraknąć innowacyjnego oświetlenia zewnętrznego. Dobrze oświetlone miejsce na zewnątrz nie tylko zapewnia bezpieczeństwo, ale także służy orientacji w terenie i tworzy atmosferę wokół domu. Oświetlenie zewnętrzne powinno spełniać wysokie wymagania jakościowe, aby bez uszkodzeń sprostać różnym warunkom, tj. wilgoć, deszcz, śnieg i sezonowe wahania temperatury. Nasze lampy zewnętrzne są produkowane z wysokiej jakości odlewane go aluminium i zapewniają niezawodność działania przez cały okres użytkowania, bez względu na pogodę, 365 dni w roku. Nowoczesna technologia LED zapewnia również dobrą jakość oświetlenia i wysoką efektywność energetyczną. Życzymy Państwu wiele radości z korzystania z naszej nowej kolekcji oświetlenia zewnętrznego.



# Serienübersicht · Family overview

Aperçu par famille · Overzicht per familie · Vista general por familia · Panoramica per famiglia ·  
Prezentare pe familii de produse · Perheen yleiskuvaus · Przegląd rodziny



ADAJA	62	NORMAN	108	ARACATI	152
AMUR	107	OHIO	67	ARBIETO	191
ARKANSAS	135	OLONA	134	ARUBA	168
BELAJA	140	PADMA	75	BAHAMAS	172
BREG	86	PEARL	36	BARBADOS	172
BRENTA	130	PECOS	82	BERMUDA	166
CANNING	112	PEDRO	87	BOGOTA	156
COLORADO	54	PIAVE	88	BOLO	176
COOPER	110	RENO	20	CALDERA	196
CUANDO	70	RHINE	24	CAMARO	160
CUBANGO	102	ROYA	50	CAMIRI	192
DONEZ	104	SACRAMENTO	64	CARMELO	194
DUERO	137	SAMBESI	120	CORDOBA	154
EBRO	32	SEINE	48	CORO	195
FUERTE	14	SHANNON	30	COTOCA	193
GAMBIA	34	SUEZ	26	DOMINGO	174
GANGES	22	TANARO	126	DORA	173
GARONNE	114	TAWA	55	ESQUEL	182
GRACHT	136	TAY	61	FOMOSA	184
HARDEY	139	THAMES	56	HAITI	169
HARLEM	66	THAMES II	58	HAWAII	170
HONDO	85	TIBER	74	JAMAICA	167
HOOSIC	92	TICINO	28	KENDAL	158
HORTON	44	TIMOK	84	LENNON	175
HUDSON	98	TRAVE	68	LOJA	197
INDUS	71	TRENT	60	LORA	173
KASAI	83	TUNGA	76	MELO	198
KATUN	18	UBANGI	145	MENDOZA	184
KAVERI	52	YANGTZE	72	MINAS	194
KELLY	138			MINEROS	186
KONDA	65			MOLINA	157
KONGO	106			MONTERO	190
LOGONE	16			PALMAS	164
MITCHEL	12			PARRAL	196
MUGA	80			POSADAS	180
MURRAY	90			ROSARIO	155
NECTOR	142			SALTA	185
NELSON	40			VINTO	188

# Produktübersicht · Product Overview

Aperçu des produits · Productoverzicht · Descripción del producto ·

Panoramica prodotto · Vizualizare produs · Tuotteen yleiskuvaus · Przegląd produktów



FUERTE  
14



SUEZ  
26



RHINE  
24



EBRO  
32



TICINO  
28



SHANNON  
30



MITCHELL  
12



NELSON  
42



GANGES  
22



PEARL  
38



SEINE  
48



TAWA  
55



HARLEM  
66



CUANDO  
70



HORTON  
46



TRAVE  
68



THAMES  
56



THAMES II  
58



TRENT  
60



LOGONE  
16



COLORADO  
54



TAY  
61



SACRAMENTO  
64



PADMA  
75



KATUN  
18



RENO  
20



COOPER  
110



ROYA  
50



TIBER  
74



KAVERI  
52



ADAJA  
62



BOGOTA  
156



CORDOBA  
154



ROSARIO  
155



ARACATI  
152



ARACATI  
152



HOOSIC  
92



HOOSIC  
96



HUDSON  
98



HUDSON  
100



MOLINA  
157



MOLINA  
157



YANGTZE  
72



INDUS  
71



TIMOK  
84



PECOS  
82



MUGA  
80



PEDRO  
87



KONDA  
65



KENDAL  
158



HONDO  
85



TRAVE  
69



BREG  
86



KENDAL  
158



CAMARO  
160



MURRAY  
90



DONEZ  
104



AMUR  
107



CUBANGO  
102



KONGO  
106



CANNING  
112



GARONNE  
114



GARONNE  
116



SAMBESI  
122



TANARO  
128



ARKANSAS  
135



GRACHT  
136



OLONA  
134



DUERO  
137



BRENTA  
130



BRENTA  
132



MITCHELL  
12



FUERTE  
14



RHINE  
24



SUEZ  
26



TICINO  
28



PEARL  
38



ROYA  
50



NELSON  
42



HORTON  
46



KAVERI  
52



SEINE  
48



LOGONE  
16



GANGES  
22



RENO  
20



KATUN  
18



COOPER  
110



KONGO  
106



SHANNON  
30



EBRO  
32



HOOSIC  
96



HUDSON  
98



CANNING  
112



GARONNE  
114



SAMBESI  
122



TANARO  
128



DONEZ  
104



CUBANGO  
102



# Sicherheit & Komfort / Sensorleuchten · Security & Comfort / Sensor Lights

Sécurité et confort / Lampes à détecteur · Veiligheid en comfort/sensorlampen · Seguridad & Comodidad / Luces del sensor ·  
Sicurezza e confort / Lampade con sensore integrat · Siguranță & confort / Lumini senzor ·  
Turvallisuus ja mukavuus/tunnistinvalaisimet · Bezpieczeństwo i komfort / światła z czujnikami



RHINE  
24



TICINO  
29



GANGES  
23



NELSON  
40



PEARL  
36

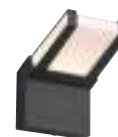

GAMBIA  
34



TUNGA  
76



TUNGA  
76



HORTON  
44



CUANDO  
70



OHIO  
67



HOOSIC  
94



HOOSIC  
94



NORMAN  
108



KASAI  
83



PIAVE  
88



HORTON  
44



PEARL  
36



NELSON  
40



GAMBIA  
34



HOOSIC  
94



SAMBESI  
126



GRACHT  
136



SAMBESI  
120

## Spots, Einbauleuchten & Zubehör ·

## Spotlights, Recessed luminaires & Accessories

Spots, lumières encastrées et accessoires · Spots, inbouwlampen en toebehoren · Puntos de luz, lámparas integradas y accesorios · Faretto, lampade da incasso e sensori · Spoturi, lămpi încorporate & accesorii · Kohdevalaisimet, upotettavat valaisimet ja tarvikkeet · Spoty, światła wpuszczane i akcesoria



TUNGA  
78



KELLY  
138



HARDEY  
139



BELAJA  
141



BELAJA  
140



UBANGI  
145



ERDSPIESS  
GROUND SPIKE  
148



ECKHALTERUNG  
CORNER FASTENING  
149



STECKDOSEN  
PLUG  
146



STECKDOSEN  
PLUG  
146



STECKDOSEN  
PLUG  
146



STECKDOSEN  
PLUG  
147

## Outdoor Living Lichtideen · Outdoor Living Lighting Ideas

Idées d'éclairage pour la vie en plein air · Lichtideeën voor buiten · Ideas de luz para la vida al aire libre · Idee di Illuminazione per l'Outdoor Living · Idei de iluminare pentru exterior · Outdoor Living -valaisinideat · Pomysły na oświetlenie zewnętrzne



ARUBA  
168



HAITI  
169



BERMUDA  
166



JAMAICA  
165



HAWAII  
170



BARBADOS  
172



BAHAMAS  
172



DORA  
173



LORA  
173



DOMINGO  
174



LENNON  
175



PALMAS  
164



NECTOR  
142



BOLO  
176

# Solarleuchten · Solar Lights

Lampes solaires · Lampen op zonne-energie · Luces solares · Lampade solari · Lāmpi solare · Aurinkovalaisimet · Światła z zasilaniem słonecznym



POSADAS  
180



ESQUEL  
182



MENDOZA  
184



FOMOSA  
184



SALTA  
185



POSADAS  
180



ESQUEL  
182



MINEROS  
186



VINTO  
188



MONTERO  
191



ARBIETO  
190



MINAS  
194



CORO  
195



LOJA  
197



COTOCA  
192



CARMELO  
194



CAMIRI  
193



PARRAL  
196



CALDERA  
196



MELO  
198

# MITCHELL

Aluminium Druckguss, Acryl  
diecast aluminium, acryl  
fonte d'aluminium, acryl  
gegoten aluminium, acryl  
aluminio fundido, acrílico  
pressofusione di alluminio, acrilico  
fonta aluminiu, acrilic  
valualumiini, akryyli  
barwione aluminium, akryl

**42** Anthrazit · anthracite

Incl. 1 x SMD-LED, 7,5 W  
750 lm, 3.000 K

**273360142**

**IP54**

Incl. 1 x SMD-LED, 16,5 W  
1.800 lm, 3.000 K

**473360442**

**473369442**

**IP54**



**273360142**



**473360442**



**473369442**

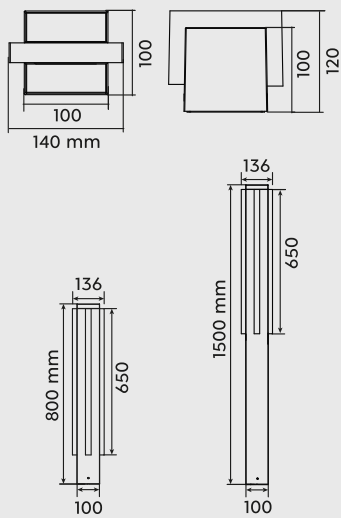



# FUERTE

Aluminium Druckguss, Acryl  
diecast aluminium, acryl  
fonte d'aluminium, acryl  
gegoten aluminium, acryl  
aluminio fundido, acrílico  
pressofusione di alluminio, acrilico  
fonta aluminiu, acrilic  
valualumiini, akryyli  
barwione aluminium, akryl

**42** Anthrazit · anthracite

Incl. 1 x SMD-LED, 10,5 W  
1.300 lm, 3.000 K

**226260142**

**IP54**

Incl. 1 x SMD-LED, 15 W  
1.700 lm, 3.000 K

**426260142**

**526260142**

**IP54**



**226260142**



**426260142**



**526260142**

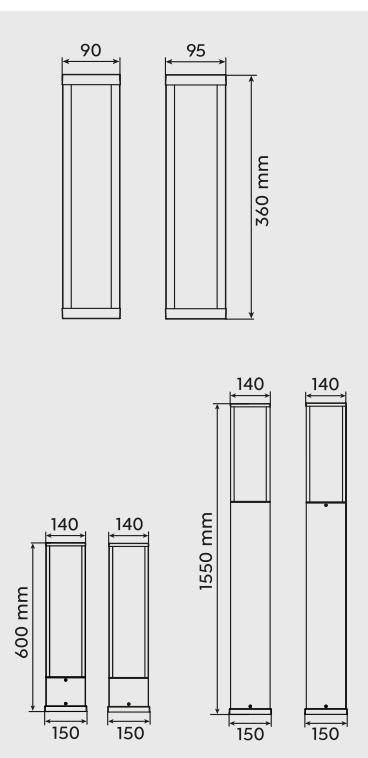



222

# LOGONE

Aluminium Druckguss  
diecast aluminium  
fonte d'aluminium  
gegoten aluminium  
aluminio fundido  
pressofusione di alluminio  
fonta aluminiu  
valualumiini  
barwione aluminium

**42** Anthrazit · anthracite

Incl. SMD-LED, 11 W  
1.100 lm, 3.000 K

IP65

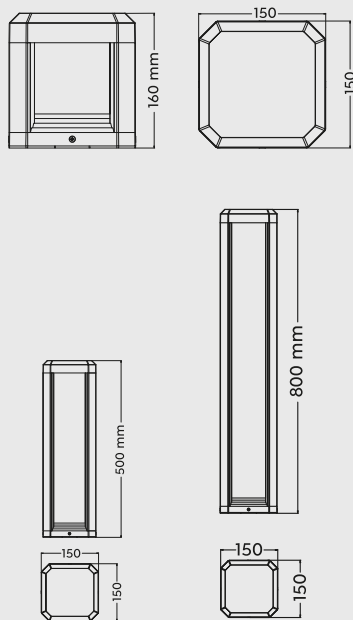

222360142



522360142



422360142

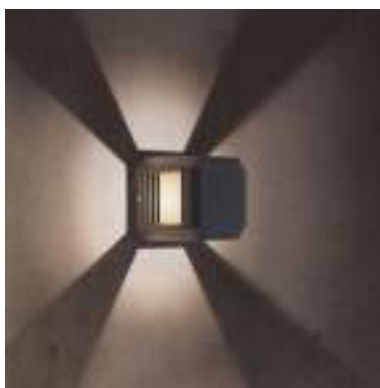





# KATUN

Aluminium Druckguss  
diecast aluminium  
fonte d'aluminium  
gegoten aluminium  
aluminio fundido  
pressofusione di alluminio  
fonta aluminii  
valualumiini  
barwione aluminium

**42** Anthrazit · anthracite

Incl. 1 x SMD-LED, 5 W  
500 lm, 3.000 K

**IP54**

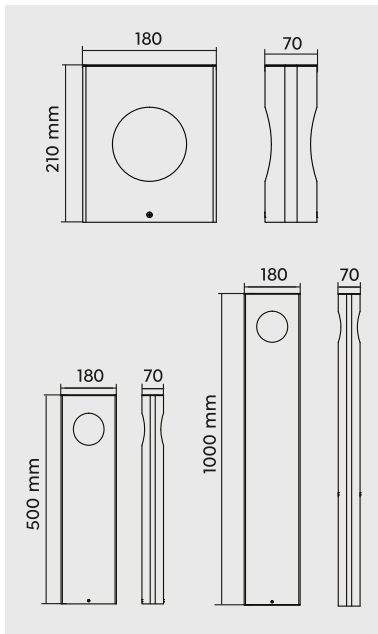

226160142



526160142



426160142





# RENO

Aluminium Druckguss  
diecast aluminium  
fonte d'aluminium  
gegoten aluminium  
aluminio fundido  
pressofusione di alluminio  
fonta aluminu  
valualumiini  
barwione aluminium

**42** Anthrazit · anthracite

Incl. 1 x COB-LED, 4,5 W  
450 lm, 3.000 K

**IP54**

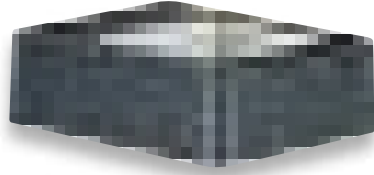
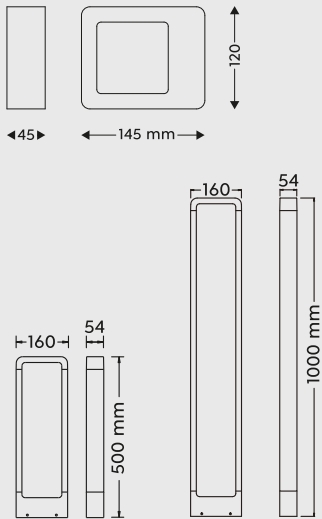

220760142

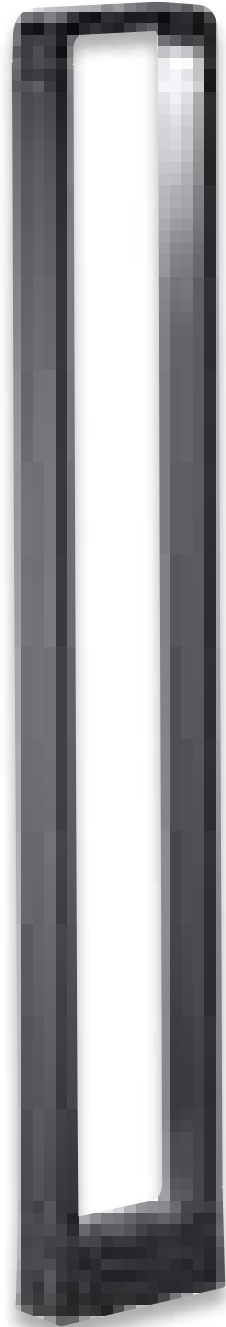

420760142

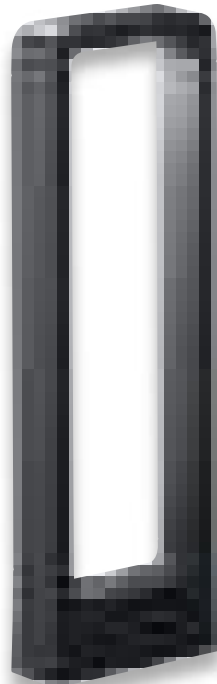

520760142

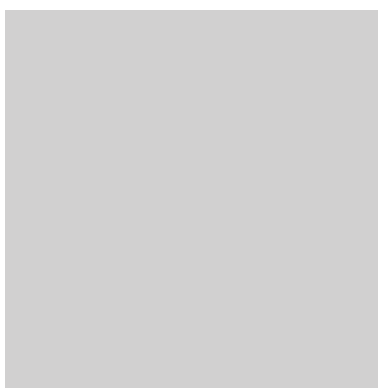
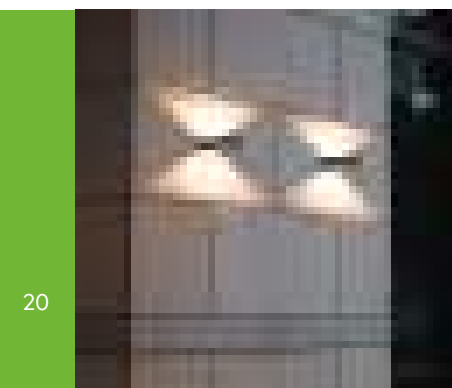



# GANGES

Aluminium Druckguss  
diecast aluminium  
fonte d'aluminium  
gegoten aluminium  
aluminio fundido  
pressofusione di alluminio  
fonta aluminu  
valualumiini  
barwione aluminium

**42** Anthrazit · anthracite

Incl. 1 x SMD-LED, 9 W  
1.000 lm, 3.000 K

**IP54**

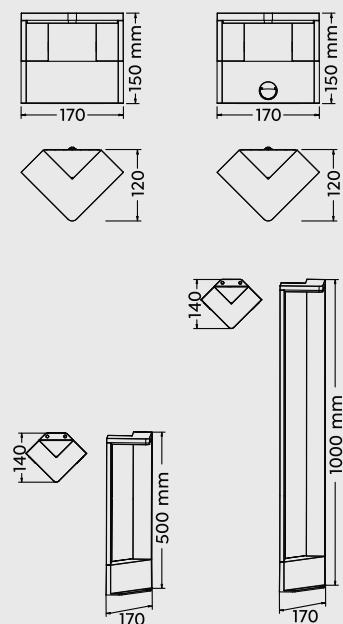

221760142



521760142



421760142





221769142



Bewegungssensor  
Motion sensor  
Décteur de mouvement  
Bewegingssensor  
Sensor de movimiento  
Sensore di movimento  
Senzor de mişcare  
Liiketunnistin  
Czujnik ruchu

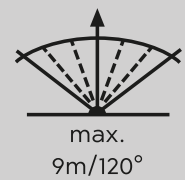

# RHINE

Aluminium Druckguss, Kunststoff  
 diecast aluminium, plastic  
 fonte d'aluminium, plastique  
 gegoten aluminium, kunststof  
 aluminio fundido, plástico  
 pressofusione di alluminio, plastica  
 fonta aluminiu, plastic  
 valualumiini, muov  
 barwione aluminium, plastik

**42** Anthrazit · anthracite

Incl. 2 x SMD-LED, 4,5 W  
 2 x 450 lm, 3.000 K

**221660242**

**221669242**

Incl. 2 x SMD-LED, 5,5 W  
 2 x 600 lm, 3.000 K

**421660242**

**521660242**

**IP54**

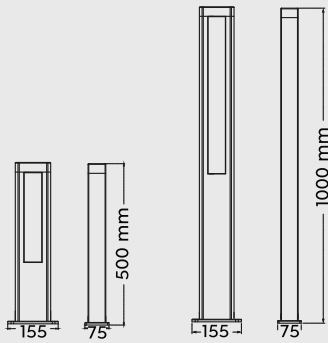
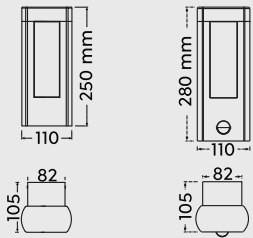

**221660242**

**221669242**



**521660242**



**421660242**

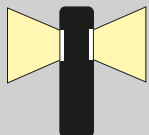



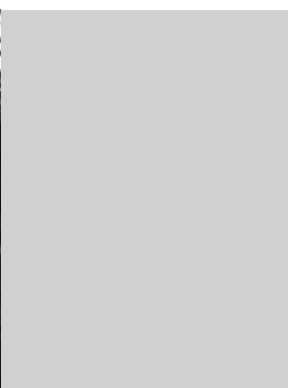

Bewegungssensor  
Motion sensor  
Détecteur de mouvement  
Bewegungssensor  
Sensor de movimiento  
Sensore di movimento  
Senzor de mișcare  
Liiketunnistin  
Czujnik ruchu

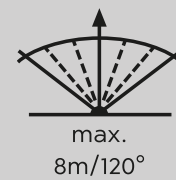

# SUEZ

Aluminium Druckguss, Kunststoff  
diecast aluminium, plastic  
fonte d'aluminium, plastique  
gegoten aluminium, kunststof  
aluminio fundido, plástico  
pressofusione di alluminio, plastica  
fonta aluminiu, plastic  
valualumiini, muovi  
barwione aluminium, plastik

**42** Anthrazit · anthracite

Incl. 1 x SMD-LED, 8,5 W  
1.000 lm, 3.000 K

**IP54**

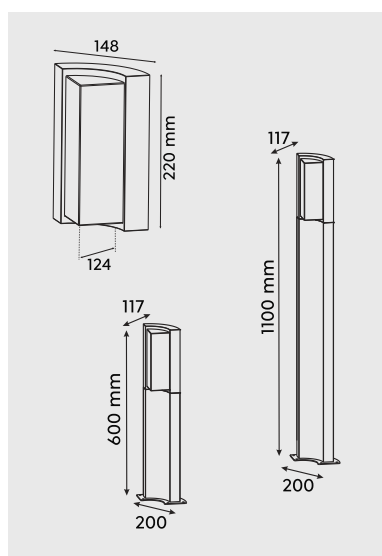

220360142



520360142



420360142

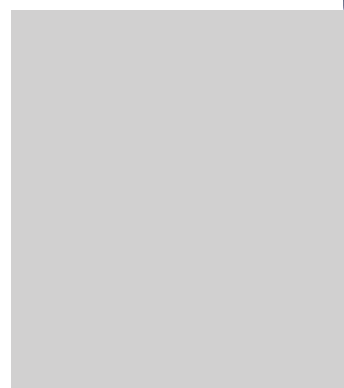
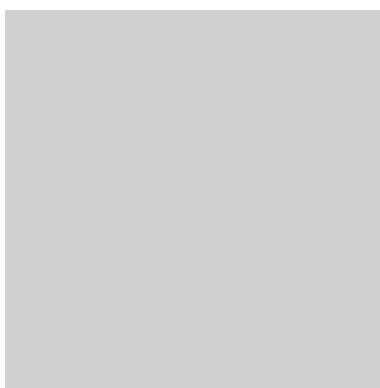



# TICINO

Aluminium Druckguss, Kunststoff  
diecast aluminium, plastic  
fonte d'aluminium, plastique  
gegoten aluminium, kunststof  
aluminio fundido, plástico  
pressofusione di alluminio, plastica  
fonta aluminiu, plastic  
valualumiini, muovi  
barwione aluminium, plastik

**42** Anthrazit · anthracite

Incl. 1 x SMD-LED, 5,5 W  
550 lm, 3.000 K

**IP54**



221260142



421260142



521260142

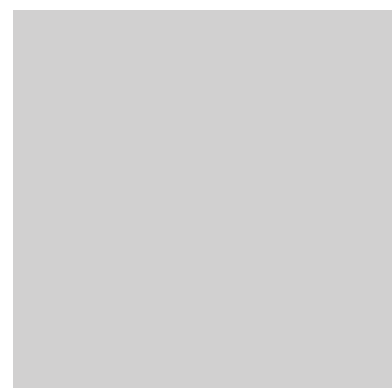
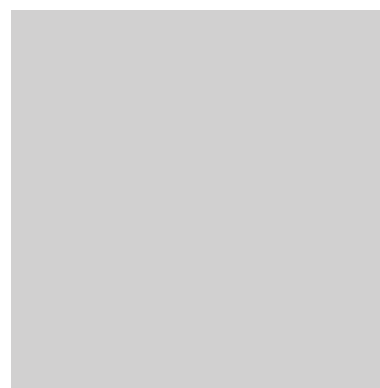
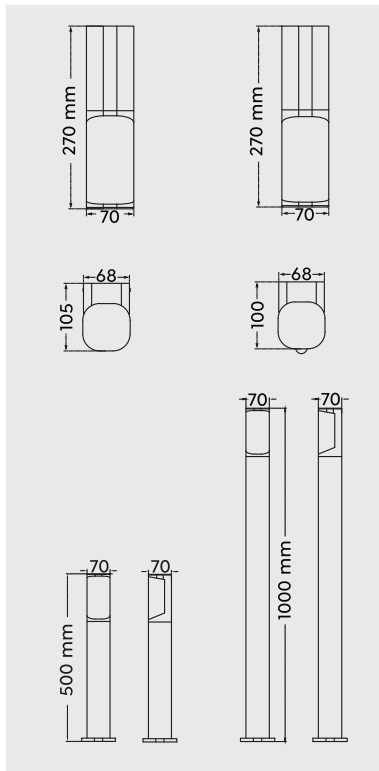



221269142



Bewegungssensor  
Motion sensor  
Décteur de mouvement  
Bewegingssensor  
Sensor de movimiento  
Sensore di movimento  
Senzor de mişcare  
Liiketunnistin  
Czujnik ruchu

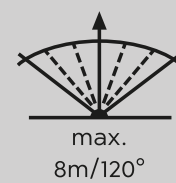

# SHANNON

Aluminium Druckguss, Kunststoff  
diecast aluminium, plastic  
fonte d'aluminium, plastique  
gegoten aluminium, kunststof  
aluminio fundido, plástico  
pressofusione di alluminio, plastica  
fonta aluminiu, plastic  
valualumiini, muovi  
barwione aluminium, plastik

**42** Anthrazit · anthracite

Incl. 1 x SMD-LED, 7 W  
700 lm, 3.000 K

**IP54**

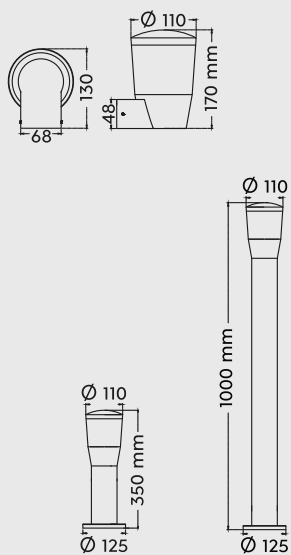

222060142



522060142



422060142





# EBRO

Aluminium Druckguss, Kunststoff  
diecast aluminium, plastic  
fonte d'aluminium, plastique  
gegoten aluminium, kunststof  
aluminio fundido, plástico  
pressofusione di alluminio, plastica  
fonta aluminiu, plastic  
valualumiini, muovi  
barwione aluminium, plastik

**42** Anthrazit · anthracite

Incl. 1 x SMD-LED, 6 W  
650 lm, 3.000 K

**IP54**



222160142



522160142



422160142

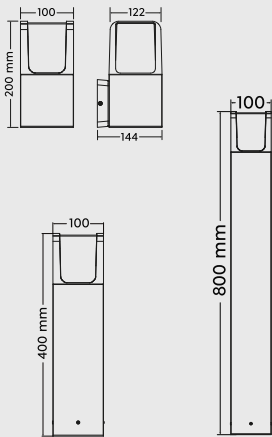



# EBRO



422167142

Aluminium Druckguss, Kunststoff  
diecast aluminium, plastic  
fonte d'aluminium, plastique  
gegoten aluminium, kunststof  
aluminio fundido, plástico  
pressofusione di alluminio, plastica  
fonta aluminiu, plastic  
valualumiini, muovi  
barwione aluminium, plastik

**42** Anthrazit · anthracite

Incl. 1 x SMD-LED, 6 W  
650 lm, 3.000 K

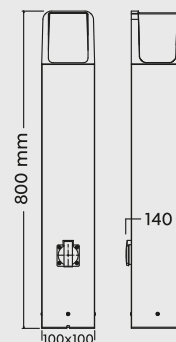

# GAMBIA

Aluminium Druckguss, Kunststoff  
diecast aluminium, plastic  
fonte d'aluminium, plastique  
gegoten aluminium, kunststof  
aluminio fundido, plástico  
pressofusione di alluminio, plastica  
fonta aluminiu, plastic  
valualumiini, muovi  
barwione aluminium, plastik

**42** Anthrazit · anthracite

Incl. 1 x SMD-LED, 10,5 W  
1.050 lm, 3.000 K

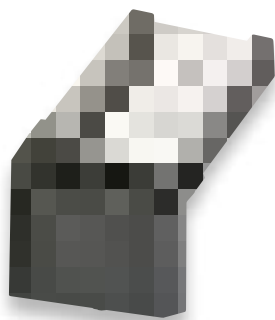
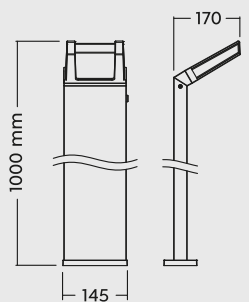
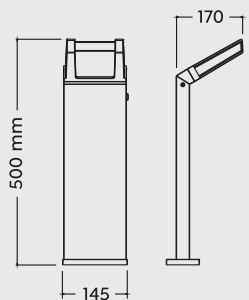
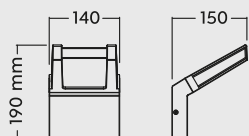

223669142



523669142



423669142



Dämmerungssensor  
Dusk sensor  
Décteur de crépuscule  
Schemeringsensor  
Sensor de oscuridad  
Sensore crepuscolare  
Senzor de lumina/amurg  
Hämärätunnistin  
Czujnik zmierzchowy





# PEARL

Aluminium Druckguss, Kunststoff  
 diecast aluminium, plastic  
 fonte d'aluminium, plastique  
 gegoten aluminium, kunststof  
 aluminio fundido, plástico  
 pressofusione di alluminio, plastica  
 fonta aluminiu, plastic  
 valualumiini, muov  
 barwione aluminium, plastik

**42** Anthrazit · anthacite

Incl. 1 x SMD-LED, 9 W  
 900 lm, 3.000 K



221169142



521169142



421169142

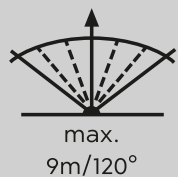
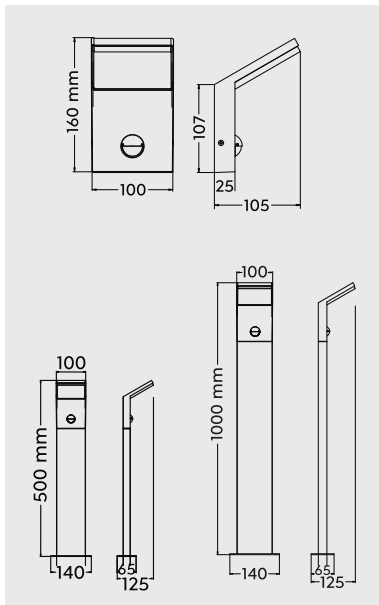

Bewegungssensor  
 Motion sensor  
 Détecteur de mouvement  
 Bewegungssensor  
 Sensor de movimiento  
 Sensore di movimento  
 Senzor de mişcare  
 Liiketunnistin  
 Czujnik ruchu





# PEARL

Aluminium Druckguss, Kunststoff  
diecast aluminium, plastic  
fonte d'aluminium, plastique  
gegoten aluminium, kunststof  
aluminio fundido, plástico  
pressofusione di alluminio, plastica  
fonta aluminiu, plastic  
valualumiini, muovi  
barwione aluminium, plastik

**42** Anthrazit · anthacite

Incl. 1 x SMD-LED, 9 W  
900 lm, 3.000 K

**IP54**

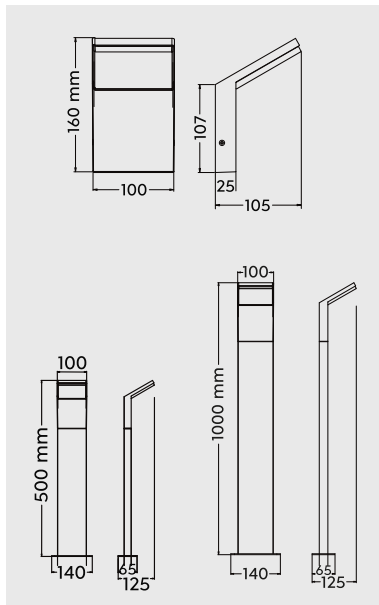

221160142



521160142



421160142





# NELSON

Aluminium Druckguss  
diecast aluminium  
fonte d'aluminium  
gegoten aluminium  
aluminio fundido  
pressofusione di alluminio  
fonta aluminiu  
valualumiini  
barwione aluminium

**42** Anthrazit · anthracite

Incl. 1 x SMD-LED, 8 W  
850 lm, 3.000 K

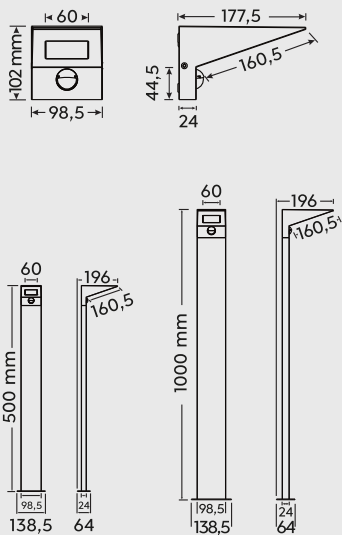

525369142



425369142







225369142



Bewegungssensor  
Motion sensor  
Détecteur de mouvement  
Bewegungssensor  
Sensor de movimiento  
Sensore di movimento  
Senzor de mișcare  
Liiketunnistin  
Czujnik ruchu

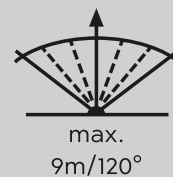

# NELSON

Aluminium Druckguss  
diecast aluminium  
fonte d'aluminium  
gegoten aluminium  
aluminio fundido  
pressofusione di alluminio  
fonta aluminiu  
valualumiini  
barwione aluminium

**42** Anthrazit · anthracite

Incl. 1 x SMD-LED, 8 W  
850 lm, 3.000 K

**IP54**

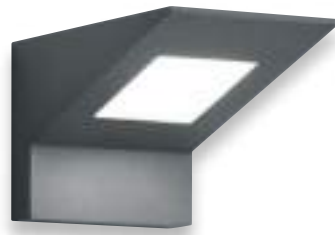
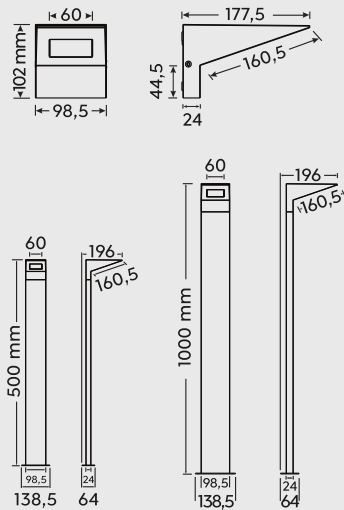

225360142



525360142



425360142





# HORTON

Aluminium Druckguss  
 diecast aluminium  
 fonte d'aluminium  
 gegoten aluminium  
 aluminio fundido  
 pressofusione di alluminio  
 fonta aluminiu  
 valualumiini  
 barwione aluminium

**42** Anthrazit · anthracite

Incl. 1 x SMD-LED, 8 W  
 1.000 lm, 3.000 K

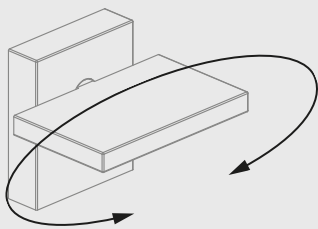
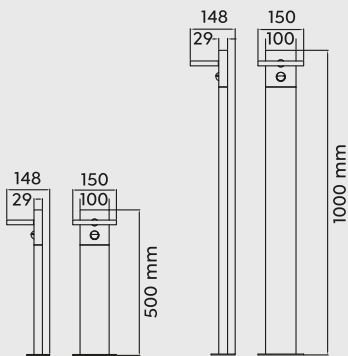
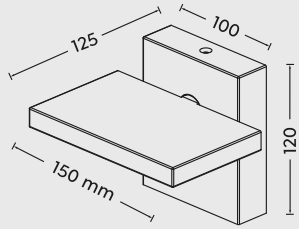

226369142



526369142



426369142

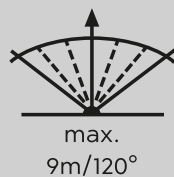

Bewegungssensor  
 Motion sensor  
 Détecteur de mouvement  
 Bewegungssensor  
 Sensor de movimiento  
 Sensore di movimento  
 Senzor de mişcare  
 Liiketunnistin  
 Czujnik ruchu



# HORTON

Aluminium Druckguss  
 diecast aluminium  
 fonte d'aluminium  
 gegoten aluminium  
 aluminio fundido  
 pressofusione di alluminio  
 fonta aluminu  
 valualumiini  
 barwione aluminium

**42** Anthrazit · anthracite

Incl. 1 x SMD-LED, 8 W  
 1.000 lm, 3.000 K

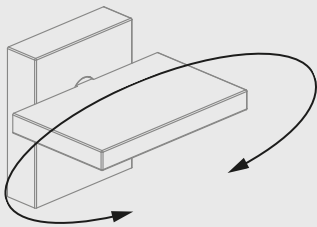
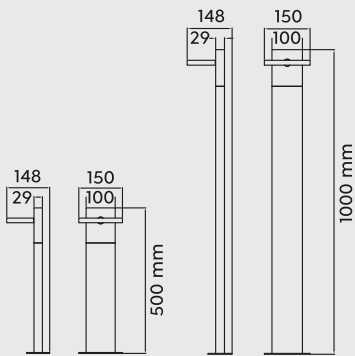
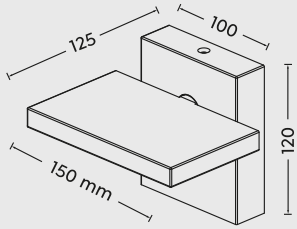

226360142



526360142



426360142

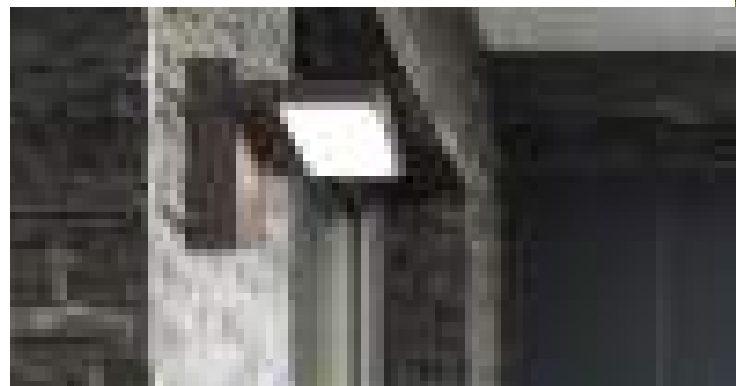
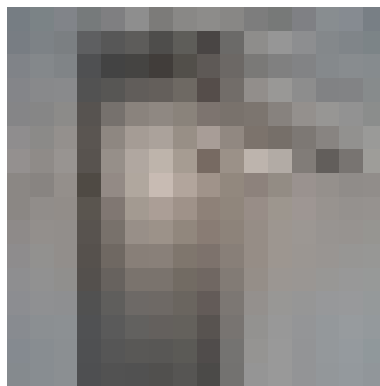



# SEINE

Aluminium Druckguss, Kunststoff  
diecast aluminium, plastic  
fonte d'aluminium, plastique  
gegoten aluminium, kunststof  
aluminio fundido, plástico  
pressofusione di alluminio, plastica  
fonta aluminiu, plastic  
valualumiini, muov  
barwione aluminium, plastik

**42** Anthrazit · anthracite

Incl. 1 x SMD-LED, 6,5 W  
750 lm, 3.000 K

**IP54**



220260142



420260142



520260142

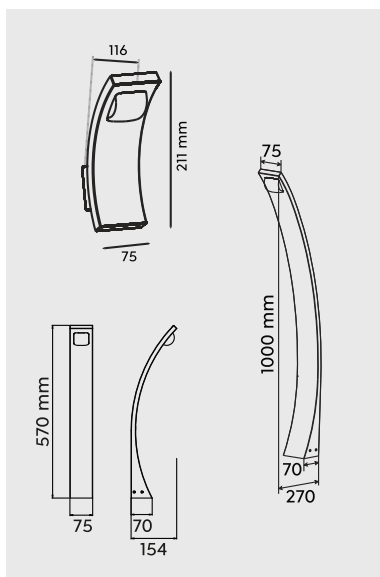





Aluminium Druckguss  
 diecast aluminium  
 fonte d'aluminium  
 gegoten aluminium  
 aluminio fundido  
 pressofusione di alluminio  
 fonta aluminiu  
 valualumiini  
 barwione aluminium

**42** Anthrazit · anthracite

Excl. 2 x GU10, max. 35 W

**204260242**

**204269242**



Excl. 1 x GU10, max. 35 W

**404260142**

**504260142**

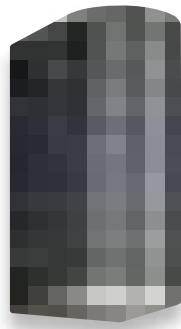
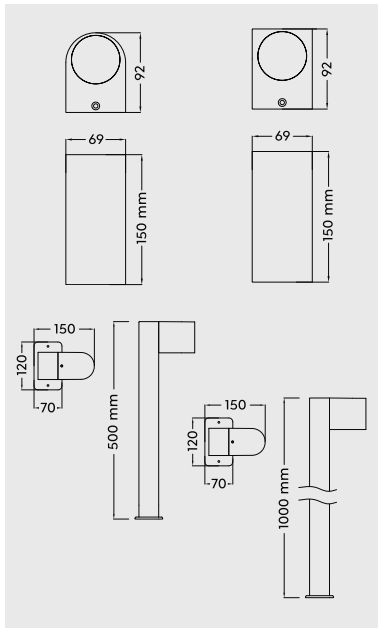

**204260242**

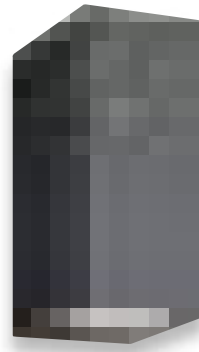

**204269242**



**504260142**



**404260142**

Empfohlen:  
 recommended:

LED GU10, 5 W  
 400 lm, 3.000 K  
 > 120°



**956-5936**

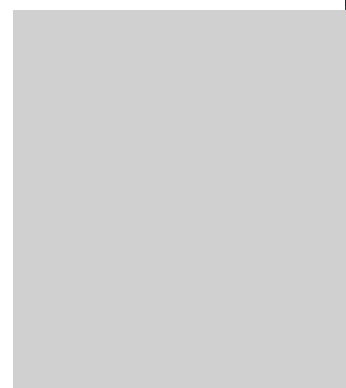
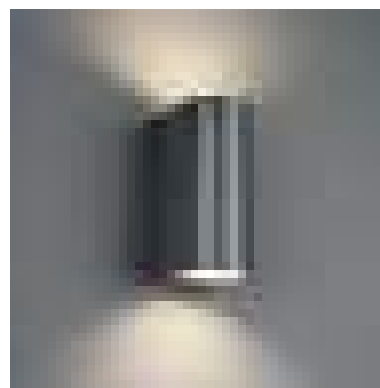
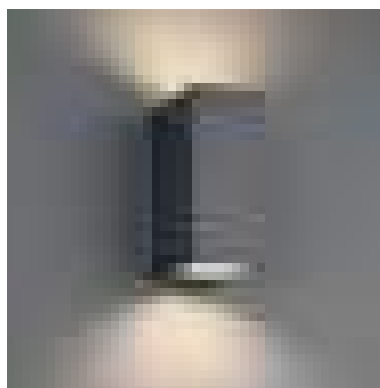



# KAVERI

Aluminium Druckguss  
diecast aluminium  
fonte d'aluminium  
gegoten aluminium  
aluminio fundido  
pressofusione di alluminio  
fonta aluminii  
valualumiini  
barwione aluminium

**42** Anthrazit · anthracite

Excl. 1 x GU10, max. 28 W



**IP44**

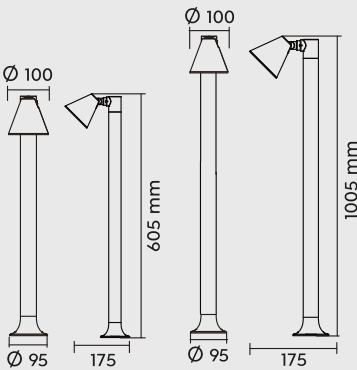
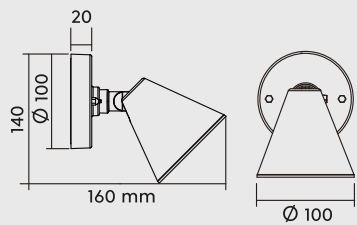

**206060142**

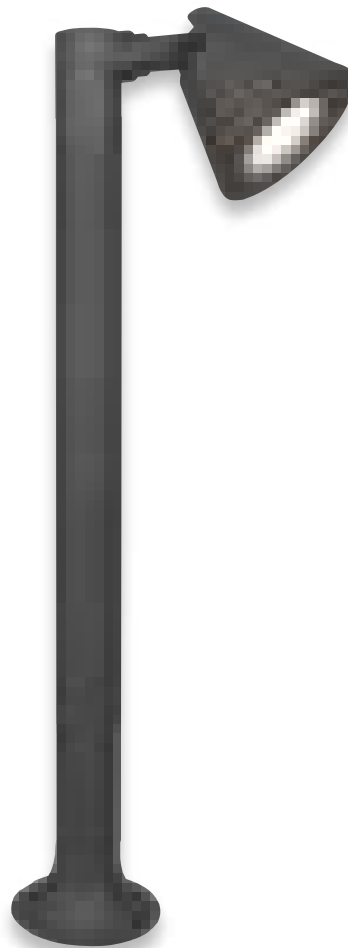

**506060142**

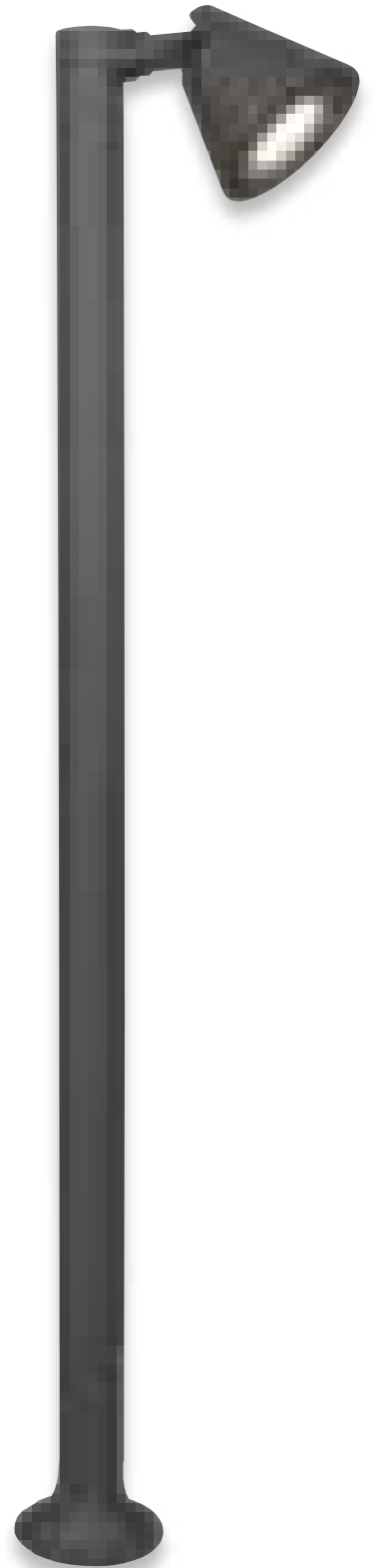

**406060142**

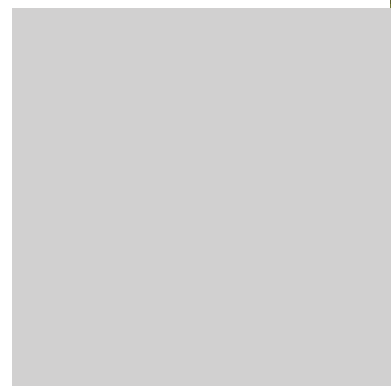



# COLORADO

Aluminium Druckguss  
diecast aluminium  
fonte d'aluminium  
gegoten aluminium  
aluminio fundido  
pressofusione di alluminio  
fonta aluminiu  
valualumiini  
barwione aluminium

**42** Anthrazit · anthracite

Incl. 2 x SMD-LED, 3 W  
2 x 260 lm, 3.000 K

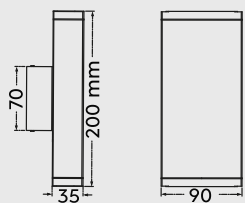

228460242

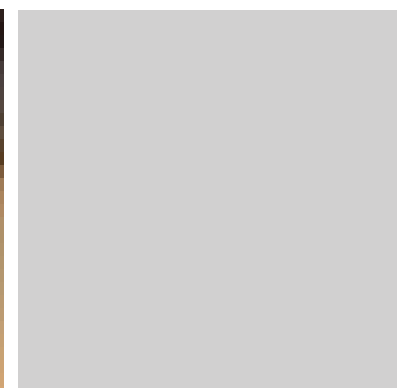
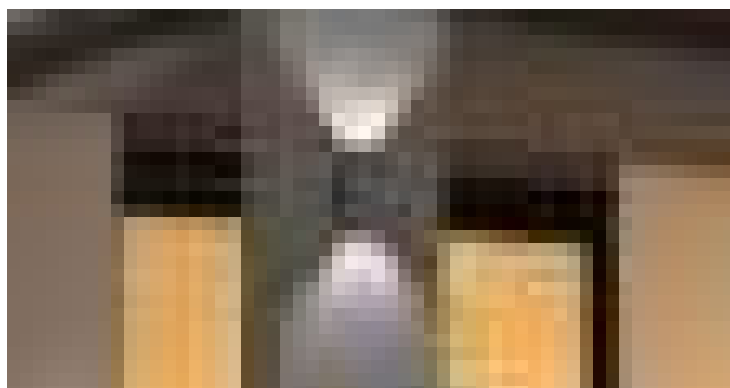
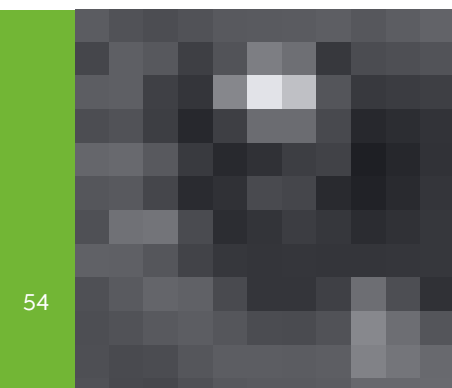



Aluminium Druckguss  
 diecast aluminium  
 fonte d'aluminium  
 gegoten aluminium  
 aluminio fundido  
 pressofusione di alluminio  
 fonta aluminiu  
 valualumiini  
 barwione aluminium

**42** Anthrazit · anthracite

Incl. 1 x SMD-LED, 7,5 W  
 800 lm, 3.000 K

**IP54**

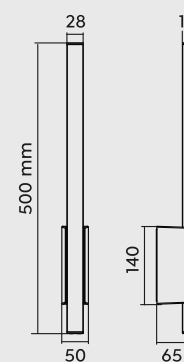

221460142



# THAMES

Aluminium Druckguss  
diecast aluminium  
fonte d'aluminium  
gegoten aluminium  
aluminio fundido  
pressofusione di alluminio  
fonta aluminiu  
valualumiini  
barwione aluminium

**42** Anthrazit · anthracite

**87** titanfarbig · titan

Incl. 2 x SMD-LED, 3 W  
2 x 180 lm, 3.000 K

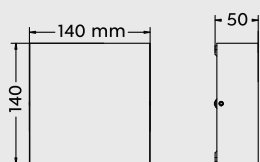

229360242



229360287







# THAMES II

Aluminium Druckguss  
 diecast aluminium  
 fonte d'aluminium  
 gegoten aluminium  
 aluminio fundido  
 pressofusione di alluminio  
 fonta aluminiu  
 valualumiini  
 barwione aluminium

**31** Weiß matt · white mat  
**42** Anthrazit · anthracite  
**87** titanfarbig · titan

Incl. 2 x SMD-LED, 2,5 W  
 2 x 260 lm, 3.000 K  
**227560231**  
**227560242**  
**227560287**



Incl. 2 x SMD-LED, 4,5 W  
 2 x 400 lm, 3.000 K  
**227660231**  
**227660242**  
**227660287**

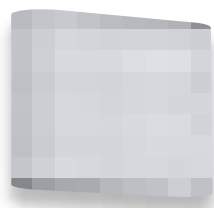
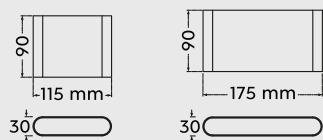

**227560231**

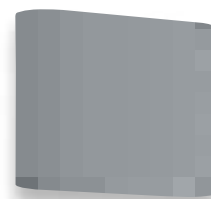

**227560287**

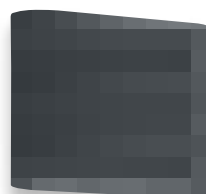

**227560242**

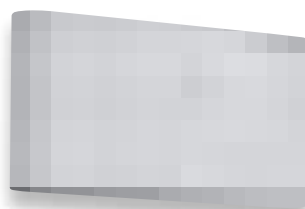

**227660231**

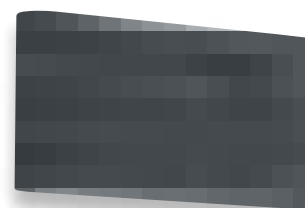

**227660242**

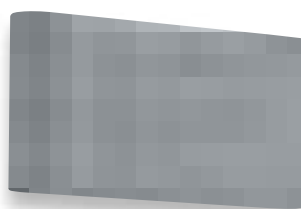

**227660287**

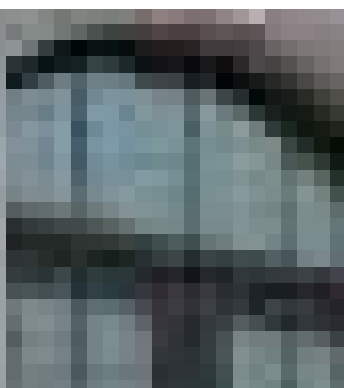
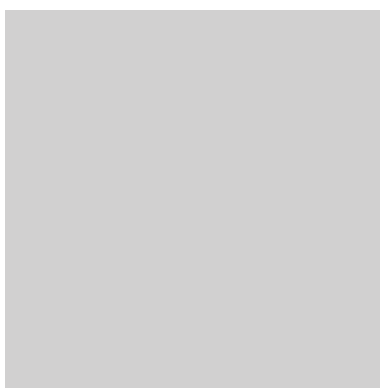
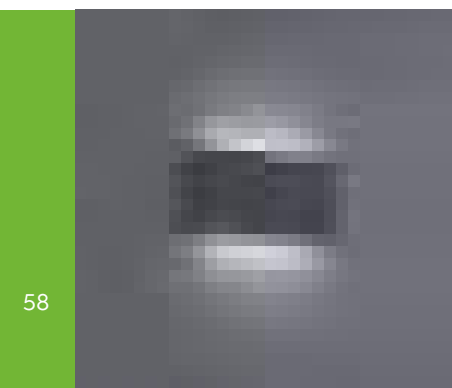

# THAMES II

Aluminium Druckguss  
diecast aluminium  
fonte d'aluminium  
gegoten aluminium  
aluminio fundido  
pressofusione di alluminio  
fonta aluminiu  
valualumiini  
barwione aluminium

- 31** Weiß matt · white mat
- 42** Anthrazit · anthracite
- 87** titanfarbig · titan

Incl. 2 x SMD-LED, 8 W  
2 x 800 lm, 3.000 K

- 226460231**
- 226460242**
- 226460287**

IP54

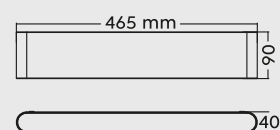

226460242

226460231

226460287

# TRENT

Aluminium Druckguss  
diecast aluminium  
fonte d'aluminium  
gegoten aluminium  
aluminio fundido  
pressofusione di alluminio  
fonta aluminu  
valualumiini  
barwione aluminium

**31** Weiß matt · white mat

**42** Anthrazit · anthracite

**87** titanfarbig · titan

Incl. SMD-LED, 10 W  
800 lm, 3.000 K

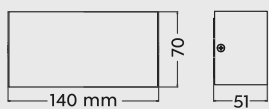

226960231



226960242



226960287

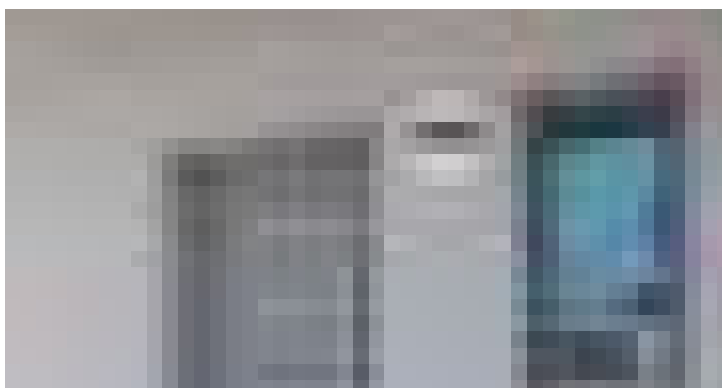

Aluminium Druckguss  
 diecast aluminium  
 fonte d'aluminium  
 gegoten aluminium  
 aluminio fundido  
 pressofusione di alluminio  
 fonta aluminiu  
 valualumiini  
 barwione aluminium

**42** Anthrazit · anthracite

Incl. 2 x SMD-LED, 4,5 W  
 2 x 450 lm, 3.000 K

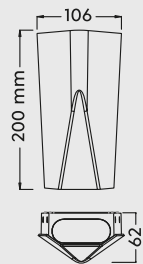

226560242



# ADAJA

Aluminium Druckguss  
diecast aluminium  
fonte d'aluminium  
gegoten aluminium  
aluminio fundido  
pressofusione di alluminio  
fonta aluminii  
valualumiini  
barwione aluminium

- 31** Weiß matt · white mat
- 42** Anthrazit · anthracite
- 87** titanfarbig · titan

Incl. 2 x SMD-LED, 3 W  
2 x 240 lm, 3.000 K

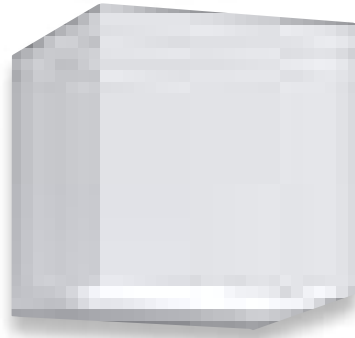
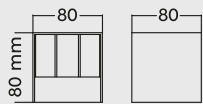

226860231

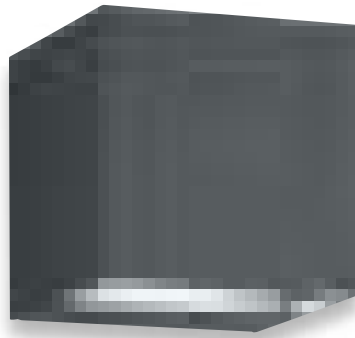

226860242

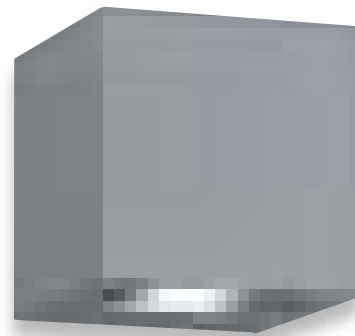

226860287

0° - 90°





# SACRAMENTO

Aluminium Druckguss  
diecast aluminium  
fonte d'aluminium  
gegoten aluminium  
aluminio fundido  
pressofusione di alluminio  
fonta aluminiu  
valualumiini  
barwione aluminium

**31** Weiß matt · white mat

**42** Anthrazit · anthracite

Incl. 1 x SMD-LED, 2 W  
200 lm, 3.000 K

Incl. 1 x SMD-LED, 5,5 W  
550 lm, 3.000 K

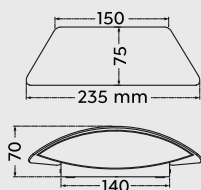

227860231



227860242





228560242

Aluminium Druckguss, Kunststoff  
diecast aluminium, plastic  
fonte d'aluminium, plastique  
gegoten aluminium, kunststof  
aluminio fundido, plástico  
pressofusione di alluminio, plastica  
fonta aluminiu, plastic  
valualumiini, muov  
barwione aluminium, plastik

**42** Anthrazit · anthracite

Incl. 1 x SMD-LED, 9 W  
850 lm, 3.000 K

IP65

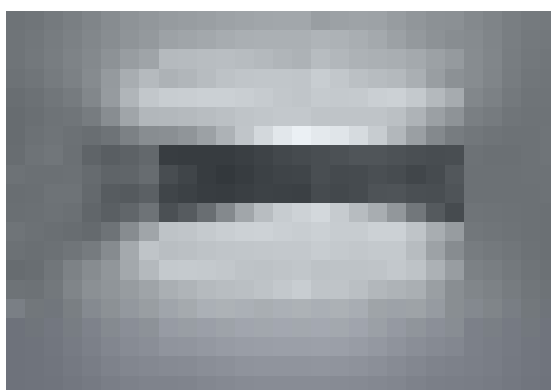
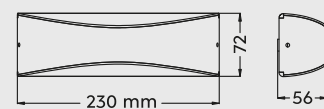

# HARLEM

Aluminium Druckguss, Kunststoff  
diecast aluminium, plastic  
fonte d'aluminium, plastique  
gegoten aluminium, kunststof  
aluminio fundido, plástico  
pressofusione di alluminio, plastica  
fonta aluminiu, plastic  
valualumiini, muovi  
barwione aluminium, plastik

**42** Anthrazit · anthracite

**87** titanfarbig · titan

Incl. 1 x SMD-LED, 6 W  
580 lm, 3.000 K

IP54

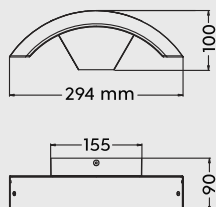

220960142



220960187

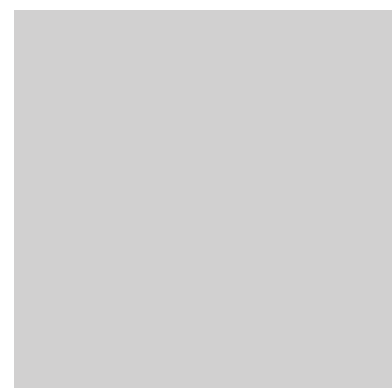
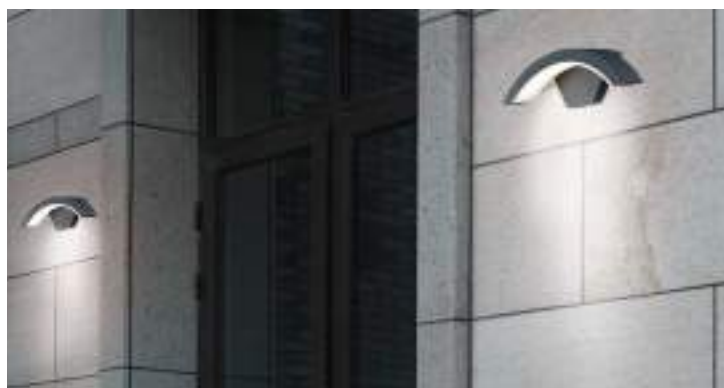

# OHIO

Aluminium Druckguss, Kunststoff  
diecast aluminium, plastic  
fonte d'aluminium, plastique  
gegoten aluminium, kunststof  
aluminio fundido, plástico  
pressofusione di alluminio, plastica  
fonta aluminiu, plastic  
valualumiini, muovi  
barwione aluminium, plastik

**42** Anthrazit · anthracite

**87** titanfarbig · titan

Incl. 1 x SMD-LED, 6 W  
580 lm, 3.000 K



220969187

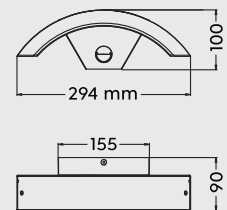

220969142



Bewegungssensor  
Motion sensor  
Décteur de mouvement  
Bewegingssensor  
Sensor de movimiento  
Sensore di movimento  
Senzor de mişcare  
Liiketunnistin  
Czujnik ruchu

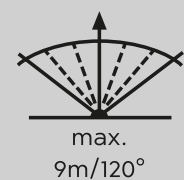

# TRAVE

Aluminium Druckguss, Kunststoff  
diecast aluminium, plastic  
fonte d'aluminium, plastique  
gegoten aluminium, kunststof  
aluminio fundido, plástico  
pressofusione di alluminio, plastica  
fonta aluminiu, plastic  
valualumiini, muovii  
barwione aluminium, plastik

**01** Weiß · white

**42** Anthrazit · anthracite

Incl. 1 x SMD-LED, 6,5 W  
700 lm, 3.000 K

**IP54**

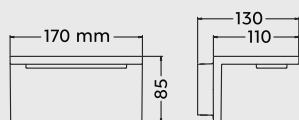

**228760101**



**228760142**



# TRAVE

Aluminium Druckguss, Kunststoff  
diecast aluminium, plastic  
fonte d'aluminium, plastique  
gegoten aluminium, kunststof  
aluminio fundido, plástico  
pressofusione di alluminio, plastica  
fonta aluminiu, plastic  
valualumiini, muovi  
barwione aluminium, plastik

**42** Anthrazit · anthracite

Incl. SMD-LED, 18 W  
1.750 lm, 3.000 K

IP54

620160142

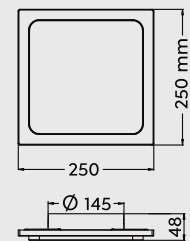

# CUANDO

Aluminium Druckguss, Acryl  
diecast aluminium, acryl  
fonte d'aluminium, acryl  
gegoten aluminium, acryl  
aluminio fundido, acrílico  
pressofusione di alluminio, acrilico  
fonta aluminiu, acrilic  
valualumiini, akryyli  
barwione aluminium, akryl

**42** Anthrazit · anthracite

Incl. SMD-LED, 14 W  
1.000 lm, 3.000 K

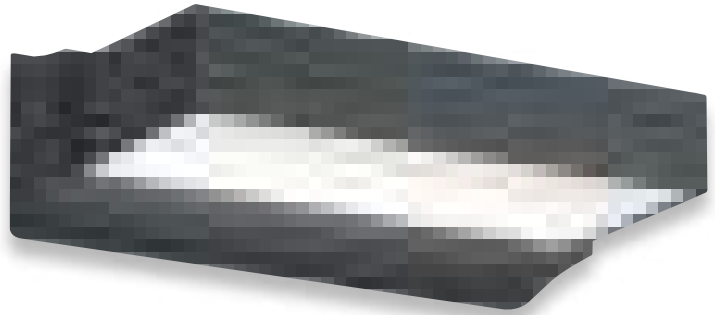

226660242

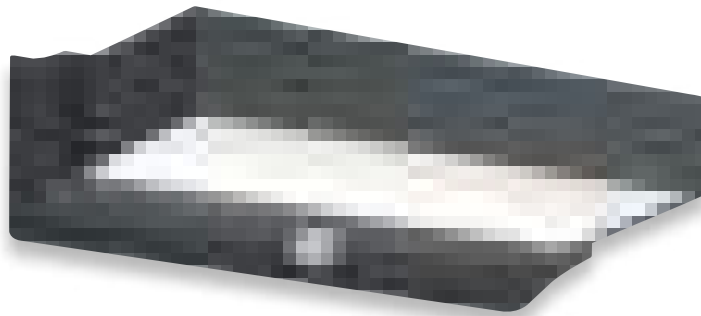
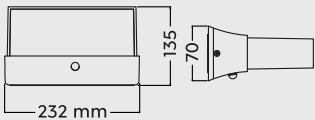
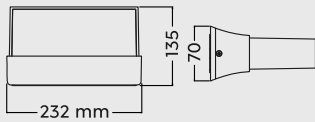

226669242

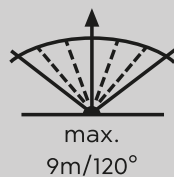

Bewegungssensor  
Motion sensor  
Détecteur de mouvement  
Bewegingssensor  
Sensor de movimiento  
Sensore di movimento  
Senzor de mişcare  
Liiketunnistin  
Czujnik ruchu

# INDUS

Aluminium Druckguss, Kunststoff  
diecast aluminium, plastic  
fonte d'aluminium, plastique  
gegoten aluminium, kunststof  
aluminio fundido, plástico  
pressofusione di alluminio, plastica  
fonta aluminiu, plastic  
valualumiini, muovi  
barwione aluminium, plastik

**42** Anthrazit · anthracite

Incl. 1 x SMD-LED, 8,5 W  
850 lm, 3.000 K

**IP54**

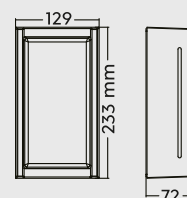

227360142



# YANGTZE

Aluminium Druckguss, Kunststoff  
diecast aluminium, plastic  
fonte d'aluminium, plastique  
gegoten aluminium, kunststof  
aluminio fundido, plástico  
pressofusione di alluminio, plastica  
fonta aluminiu, plastic  
valualumiini, muovi  
barwione aluminium, plastik

**01** Weiß · white

**42** Anthrazit · anthracite

Incl. 1 x SMD-LED, 3,5 W  
330 lm, 3.000 K

IP54

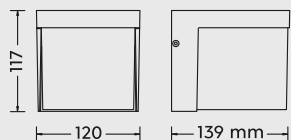

228260101



228260142





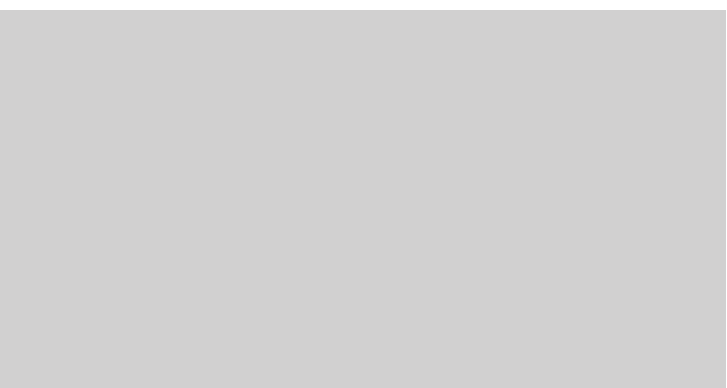

# TIBER

Aluminium Druckguss  
diecast aluminium  
fonte d'aluminium  
gegoten aluminium  
aluminio fundido  
pressofusione di alluminio  
fonta aluminiu  
valualumiini  
barwione aluminium

**42** Anthrazit · anthracite

Incl. 1 x COB-LED, 3 W  
210 lm, 3.000 K

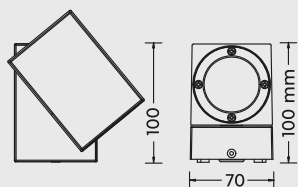

229160142

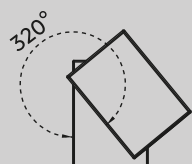

# PADMA

Aluminium Druckguss  
diecast aluminium  
fonte d'aluminium  
gegoten aluminium  
aluminio fundido  
pressofusione di alluminio  
fonta aluminiu  
valualumiini  
barwione aluminium

**42** Anthrazit · anthracite

Incl. 2 x SMD-LED, 4,5 W  
2 x 420 lm, 3.000 K



227160242

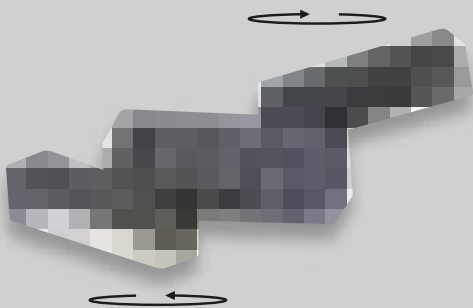
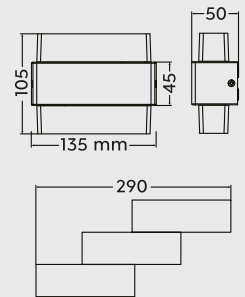

Schwenkbar  
Tiltable  
Pivotant  
Draaibaar  
Pivotante  
Girevole  
Pivotant  
Suunnattava  
Skřętny

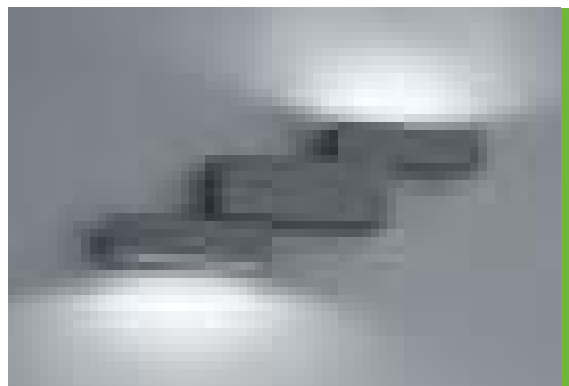

# TUNGA

Aluminium Druckguss  
 diecast aluminium  
 fonte d'aluminium  
 gegoten aluminium  
 aluminio fundido  
 pressofusione di alluminio  
 fonta aluminiu  
 valualumiini  
 barwione aluminium

**31** Weiß matt · white mat  
**42** Anthrazit · anthracite

Incl. 1 x SMD-LED, 3,5 W  
 420 lm, 3.000 K

**222969131**  
**222969142**



Incl. 2 x SMD-LED, 3,5 W  
 2 x 420 lm, 3.000 K

**222969231**  
**222969242**



222969131



222969142

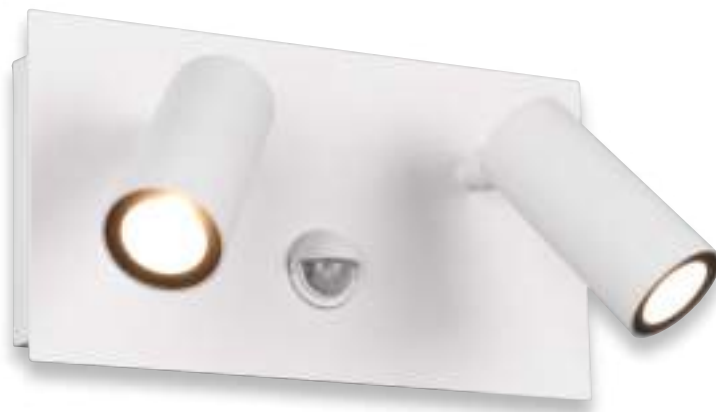

222969231

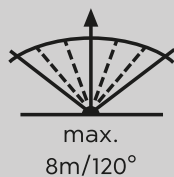
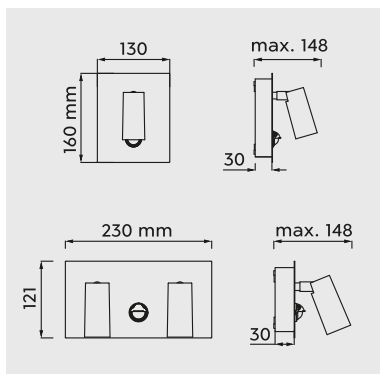

Bewegungssensor  
 Motion sensor  
 Détecteur de mouvement  
 Bewegungssensor  
 Sensor de movimiento  
 Sensore di movimento  
 Senzor de mişcare  
 Liiketunnistin  
 Czujnik ruchu



222969242

# TUNGA

Aluminium Druckguss  
diecast aluminium  
fonte d'aluminium  
gegoten aluminium  
aluminio fundido  
pressofusione di alluminio  
fonta aluminii  
valualumiini  
barwione aluminium

**31** Weiß matt · white mat

**42** Anthrazit · anthracite

Incl. 1 x SMD-LED, 3,5 W  
420 lm, 3.000 K

**222960131**

**222960142**

IP54

Incl. 2 x SMD-LED, 3,5 W  
2 x 420 lm, 3.000 K

**222960231**

**222960242**

IP54



222960131



222960142

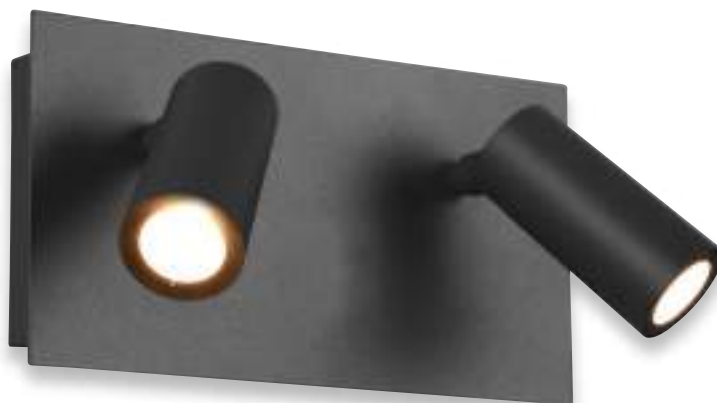

222960242

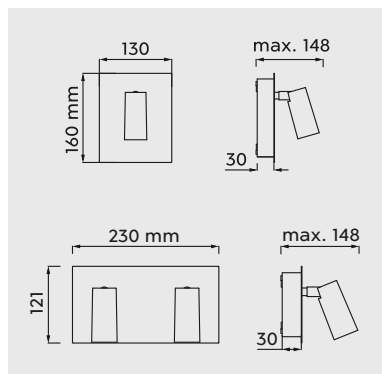



222960231

# MUGA

Aluminium Druckguss, Kunststoff  
diecast aluminium, plastic  
fonte d'aluminium, plastique  
gegoten aluminium, kunststof  
aluminio fundido, plástico  
pressofusione di alluminio, plastica  
fonta aluminu, plastic  
valualumiini, muovi  
barwione aluminium, plastik

**01** Weiß · white

**42** Anthrazit · anthracite

Incl. 1 x SMD-LED, 5 W  
550 lm, 3.000 K

IP54

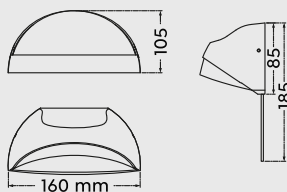

228360142



228360101







20

# PECOS

Aluminium Druckguss, Kunststoff  
diecast aluminium, plastic  
fonte d'aluminium, plastique  
gegoten aluminium, kunststof  
aluminio fundido, plástico  
pressofusione di alluminio, plastica  
fonta aluminiu, plastic  
valualumiini, muovi  
barwione aluminium, plastik

**42** Anthrazit · anthracite

Incl. 1 x SMD-LED, 6 W  
600 lm, 3.000 K

**IP54**

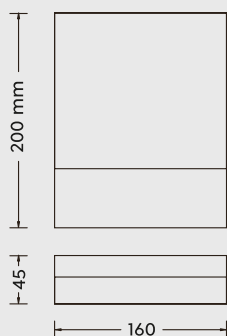

227760142



# KASAI

Aluminium Druckguss, Kunststoff  
diecast aluminium, plastic  
fonte d'aluminium, plastique  
gegoten aluminium, kunststof  
aluminio fundido, plástico  
pressofusione di alluminio, plastica  
fonta aluminiu, plastic  
valualumiini, muovi  
barwione aluminium, plastik

**42** Anthrazit · anthracite

Incl. 1 x SMD-LED, 9 W  
850 lm, 3.000 K

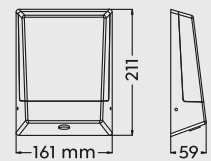

228669142



Dämmerungssensor  
Dusk sensor  
Décteur de crépuscule  
Schemeringsensor  
Sensor de oscuridad  
Sensore crepuscolare  
Senzor de lumina/amurg  
Hämärätunnistin  
Czujnik zmierzchowy  
Alacakaranlık Algılayıcısı



# TIMOK

Aluminium Druckguss, Kunststoff  
diecast aluminium, plastic  
fonte d'aluminium, plastique  
gegoten aluminium, kunststof  
aluminio fundido, plástico  
pressofusione di alluminio, plastica  
fonta aluminiu, plastic  
valualumiini, muov  
barwione aluminium, plastik

**01** Weiß · white

**42** Anthrazit · anthracite

Incl. 1 x LED E27, 5 W  
470 lm, 3.000 K

IP54

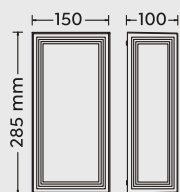

228060101



228060142



# HONDO



228960101

Aluminium Druckguss, Kunststoff  
diecast aluminium, plastic  
fonte d'aluminium, plastique  
gegoten aluminium, kunststof  
aluminio fundido, plástico  
pressofusione di alluminio, plastica  
fonta aluminiu, plastic  
valualumiini, muovi  
barwione aluminium, plastik

**01** Weiß · white

**42** Anthrazit · anthracite

Incl. 1 x SMD-LED, 3,5 W  
330 lm, 3.000 K

**IP54**

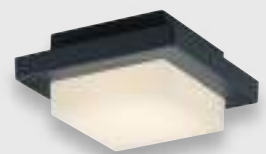
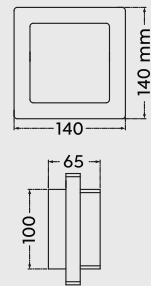

228960142



# BREG

Aluminium Druckguss, Kunststoff  
diecast aluminium, plastic  
fonte d'aluminium, plastique  
gegoten aluminium, kunststof  
aluminio fundido, plástico  
pressofusione di alluminio, plastica  
fonta aluminiu, plastic  
valualumiini, muovi  
barwione aluminium, plastik

**42** Anthrazit · anthracite

Incl. 1 x SMD-LED, 8,5 W  
850 lm, 3.000 K

IP54

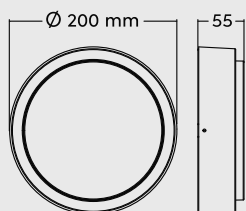

227260142

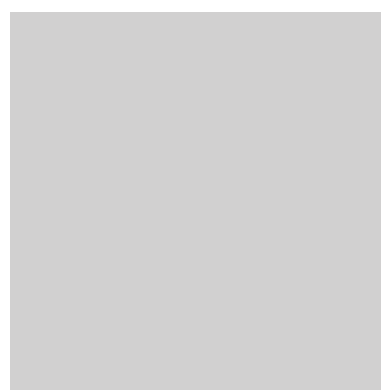

# PEDRO

Aluminium Druckguss, Acryl  
diecast aluminium, acryl  
fonte d'aluminium, acryl  
gegoten aluminium, acryl  
aluminio fundido, acrílico  
pressofusione di alluminio, acrilico  
fonta aluminiu, acrilic  
valualumiini, akryyli  
barwione aluminium, akryl

**42** Anthrazit · anthracite

Incl. 1 x SMD-LED, 9 W  
1.000 lm, 3.000 K

**IP54**

222860142

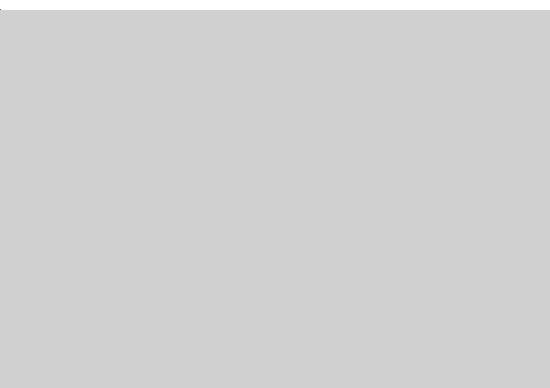
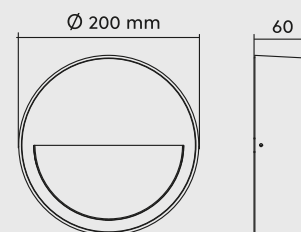

# PIAVE

Kunststoff  
plastic  
plastique  
kunststof  
plástico  
plastica  
plastic  
muovi  
plastik

**31** Weiß matt · white mat

**42** Anthrazit · anthracite

Incl. SMD-LED, 12 W  
1.000 lm, 3.000 K

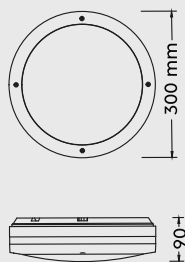

676960131



676960142

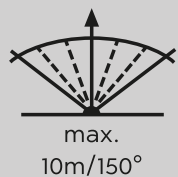

Bewegungssensor  
Motion sensor  
Détecteur de mouvement  
Bewegingssensor  
Sensor de movimiento  
Sensore di movimento  
Senzor de mişcare  
Liiketunnistin  
Czujnik ruchu







# MURRAY

Kunststoff  
plastic  
plastique  
kunststof  
plástico  
plastica  
plastic  
muovi  
plastik

**24** rostfarbig · rusty

**78** betonfarbig · concrete look

Excl. 2 x E27, max. 12 W



IP54

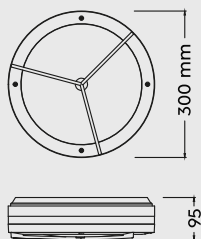

676160224



676160278

Empfohlen:  
recommended:

LED E27, 6 W  
470 lm, 3.000 K



987-60





# HOOSIC

Aluminium Druckguss, Kunststoff  
 diecast aluminium, plastic  
 fonte d'aluminium, plastique  
 gegoten aluminium, kunststof  
 aluminio fundido, plástico  
 pressofusione di alluminio, plastica  
 fonta aluminiu, plastic  
 valualumiini, muovi  
 barwione aluminium, plastik

**24** rostfarbig · rusty

Excl. 1 x E27, max. 28 W

**222260124**

**422260124**

**522260124**

Excl. 2 x E27, max. 28 W

**222260224**



**IP44**



**222260124**



**222260224**



**422260124**



**522260124**

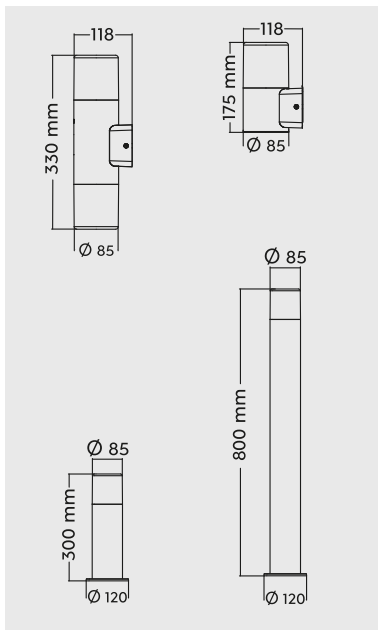

Empfohlen:  
 recommended:

Filament LED  
 E27, 6 W  
 470 lm, 3.000 K



**987-60**





# HOOSIC

Aluminium Druckguss, Kunststoff  
 diecast aluminium, plastic  
 fonte d'aluminium, plastique  
 gegoten aluminium, kunststof  
 aluminio fundido, plástico  
 pressofusione di alluminio, plastica  
 fonta aluminiu, plastic  
 valualumiini, muovi  
 barwione aluminium, plastik

**42 Anthrazit · anthracite**

Excl. 1 x E27, max. 28 W

**222260142**

**422260142**

**522260142**

Excl. 2 x E27, max. 28 W

**222260242**



**222260142**



**222260242**



**422260142**



**522260142**

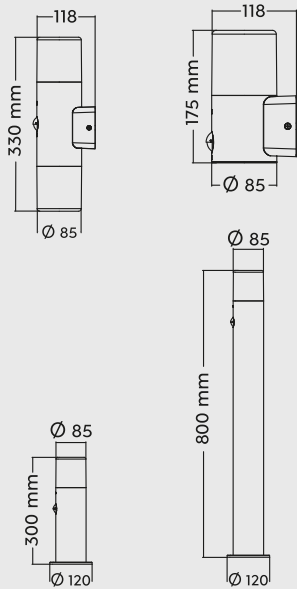

Empfohlen:  
 recommended:

Filament LED  
 E27, 6 W  
 470 lm, 3.000 K



**987-60**



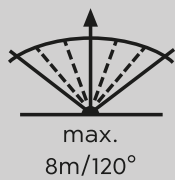

Bewegungssensor  
Motion sensor  
Décteur de mouvement  
Bewegungssensor  
Sensor de movimiento  
Sensore di movimento  
Senzor de mişcare  
Liiketunnistin  
Czujnik ruchu



# HOOSIC

Aluminium Druckguss, Kunststoff  
 diecast aluminium, plastic  
 fonte d'aluminium, plastique  
 gegoten aluminium, kunststof  
 aluminio fundido, plástico  
 pressofusione di alluminio, plastica  
 fonta aluminiu, plastic  
 valualumiini, muovi  
 barwione aluminium, plastik

**42 Anthrazit · anthracite**

Excl. 1 x E27, max. 28 W

**224060142**

**424060142**

**524060142**

Excl. 2 x E27, max. 28 W

**224060242**



**IP44**



**224060142**



**224060242**



**424060142**



**524060142**

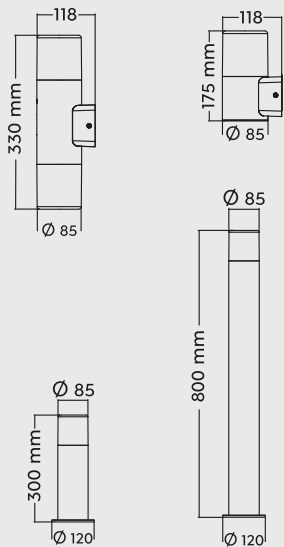

Empfohlen:  
 recommended:

Filament LED  
 E27, 6 W  
 470 lm, 3.000 K



**987-60**





# HOOSIC



424067142

Aluminium Druckguss, Kunststoff  
diecast aluminium, plastic  
fonte d'aluminium, plastique  
gegoten aluminium, kunststof  
aluminio fundido, plástico  
pressofusione di alluminio, plastica  
fonta aluminiu, plastic  
valualumiini, muovi  
barwione aluminium, plastik

**42** Anthrazit · anthracite

Excl. 1 x E27, max. 28 W



**IP44**

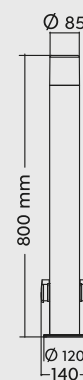

x 2



# HUDSON

Aluminium Druckguss, Kunststoff  
 diecast aluminium, plastic  
 fonte d'aluminium, plastique  
 gegoten aluminium, kunststof  
 aluminio fundido, plástico  
 pressofusione di alluminio, plastica  
 fonta aluminiu, plastic  
 valualumiini, muov  
 barwione aluminium, plastik

**42** Anthrazit · anthracite

Incl. 1 x LED E14, 4 W  
 320 lm, 3.000 K

**220060142**

**420060142**

**520060142**

Incl. 2 x LED E14, 4 W  
 2 x 320 lm, 3.000 K

**220060242**

**IP44**



**220060142**



**220060242**



**520060142**



**420060142**

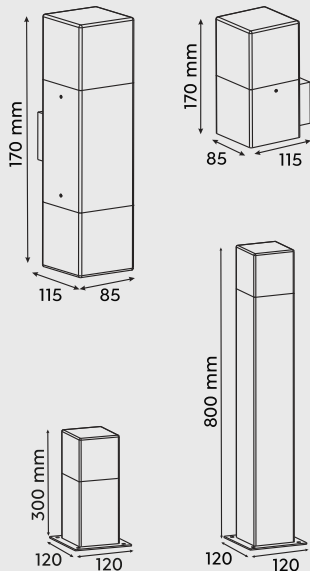

Incl. LED E14, 4 W  
 320 lm, 3.000 K



**983-40**





# HUDSON

Aluminium Druckguss, Kunststoff  
 diecast aluminium, plastic  
 fonte d'aluminium, plastique  
 gegoten aluminium, kunststof  
 aluminio fundido, plástico  
 pressofusione di alluminio, plastica  
 fonta aluminiu, plastic  
 valualumiini, muovi  
 barwione aluminium, plastik

**87** titanfarbig · titan

Incl. 1 x LED E14, 4 W  
 320 lm, 3.000 K

**220060187**

**420060187**

**520060187**

Incl. 2 x LED E14, 4 W  
 2 x 320 lm, 3.000 K

**220060287**

IP44

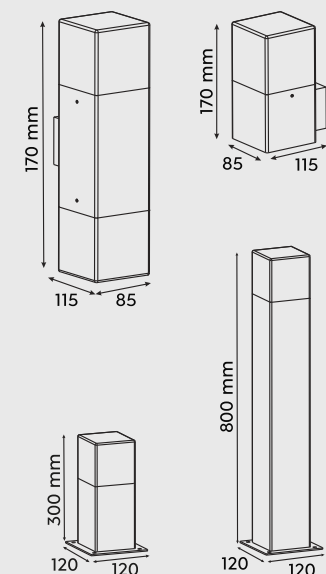

**220060187**



**220060287**



**520060187**



**420060187**

Incl. LED E14, 4 W  
 320 lm, 3.000 K



**983-40**





# CUBANGO

Aluminium Druckguss, Kunststoff  
diecast aluminium, plastic  
fonte d'aluminium, plastique  
gegoten aluminium, kunststof  
aluminio fundido, plástico  
pressofusione di alluminio, plastica  
fonta aluminiu, plastic  
valualumiini, muovi  
barwione aluminium, plastik

**42** Anthrazit · anthracite

Incl. 1 x LED E27, 5 W  
400 lm, 3.000 K

**IP54**

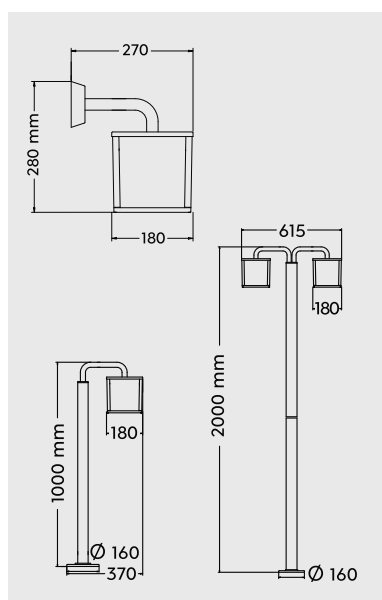

221560142



421560142



421560242

Incl. LED E27, 5 W  
400 lm, 3.000 K



**986-60**





# DONEZ

Aluminium Druckguss, Glas  
diecast aluminium, glass  
fonte d'aluminium, verre  
gegoten aluminium, glas  
aluminio fundido, vidrio  
pressofusione di alluminio, vetro  
fonta aluminiu, sticla  
valualumiini, lasi  
barwione aluminium, szkło

**42** Anthrazit · anthracite

Excl. 1 x E27, max. 40 W

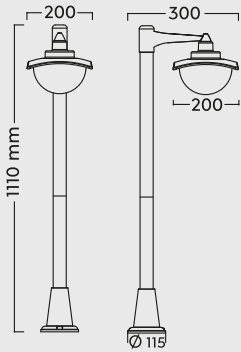
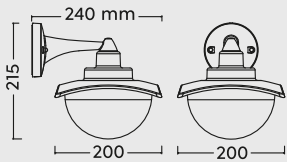

204960142



404960142

Empfohlen:  
recommended:

LED E27, 5 W  
400 lm, 3.000 K







# KONGO

Aluminium Druckguss, Kunststoff  
diecast aluminium, plastic  
fonte d'aluminium, plastique  
gegoten aluminium, kunststof  
aluminio fundido, plástico  
pressofusione di alluminio, plastica  
fonta aluminiu, plastic  
valualumiini, muovi  
barwione aluminium, plastik

**42** Anthrazit · anthracite

Incl. 1 x LED E27, 5 W  
400 lm, 3.000 K

**IP44**

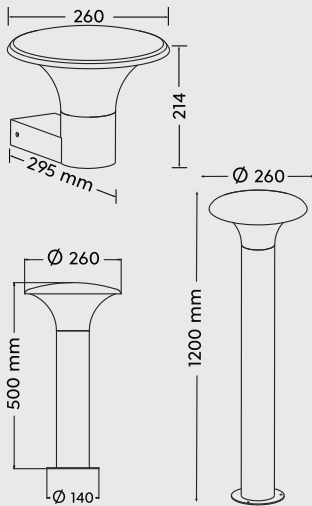

**220160142**



**420160142**



**520160142**

Incl. LED E27, 5 W  
400 lm, 3.000 K



**986-60**



# AMUR

Aluminium Druckguss, Kunststoff  
diecast aluminium, plastic  
fonte d'aluminium, plastique  
gegoten aluminium, kunststof  
aluminio fundido, plástico  
pressofusione di alluminio, plastica  
fonta aluminiu, plastic  
valualumiini, muovi  
barwione aluminium, plastik

**31** Weiß matt · white mat

**88** Silber antik · antique silver

Excl. 1 x E27, max. 60 W



IP44

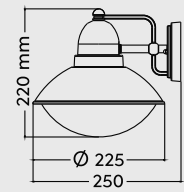

227460188



227460131

Empfohlen:  
recommended:

LED E27, 6 W  
470 lm, 3.000 K



987-60

# NORMAN

Aluminium Druckguss, Acryl  
diecast aluminium, acryl  
fonte d'aluminium, acryl  
gegoten aluminium, acryl  
aluminio fundido, acrílico  
pressofusione di alluminio, acrilico  
fonta aluminiu, acrilic  
valualumiini, akryyli  
barwione aluminium, akryl

**24** rostfarbig · rusty

**31** Weiß matt · white mat

**42** Anthrazit · anthracite

Excl. 1 x E27, max. 40 W

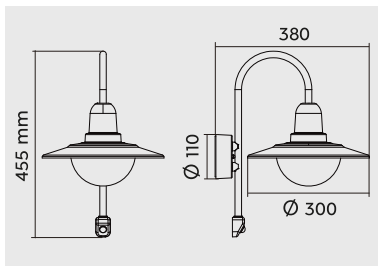

207269131



207269142

Empfohlen:  
recommended:

LED E27, 6 W  
470 lm, 3.000 K



987-60

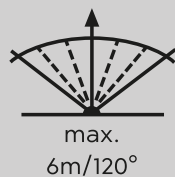

max.  
6m/120°



Bewegungssensor  
Motion sensor  
Détecteur de mouvement  
Bewegingssensor  
Sensor de movimiento  
Sensore di movimento  
Senzor de mişcare  
Liiketunnistin  
Czujnik ruchu



207269124

# COOPER

Edelstahl, Kunststoff  
steel, plastic  
acier, plastique  
staal, kunststof  
acero, plástico  
acciaio, plastica  
inox, plastic  
teräs, muovi  
stal, plastik

**42** Anthrazit · anthracite

Excl. 1 x E27, max. 40 W



**IP44**

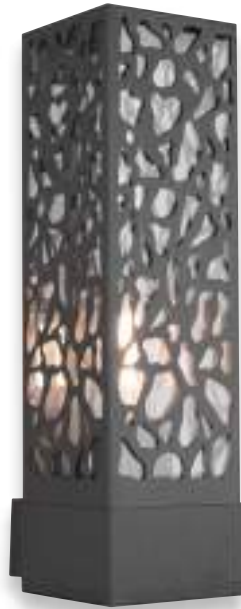

207360142



507360142



407360142

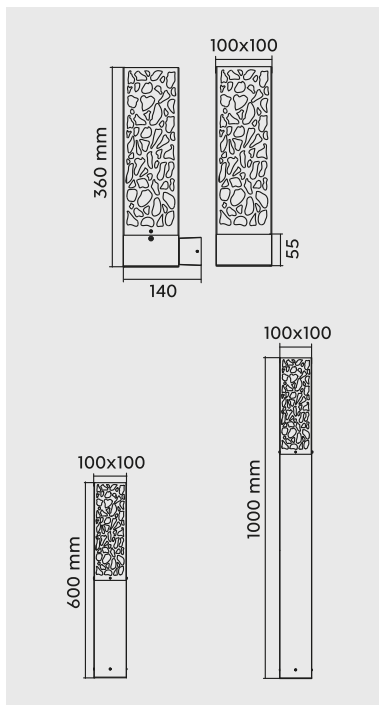

Empfohlen:  
recommended:

LED E27, 6 W  
470 lm, 3.000 K



**987-400**





# CANNING

Aluminium Druckguss, Naturholz  
 diecast aluminium, natural wood  
 fonte d'aluminium, bois naturel  
 gegoten aluminium, natuur hout  
 aluminio fundido, madera natural  
 pressofusione di alluminio, legno naturale  
 fonta aluminiu, lemn natural  
 valualumiini, luonnonpuu  
 barwione aluminium, drewno naturalne

**30** holzfarbig / Anthrazit ·  
 wood coloured / anthracite

Excl. 1 x GU10, max. 28 W



**IP44**



**209660130**



**409660130**



**509660130**

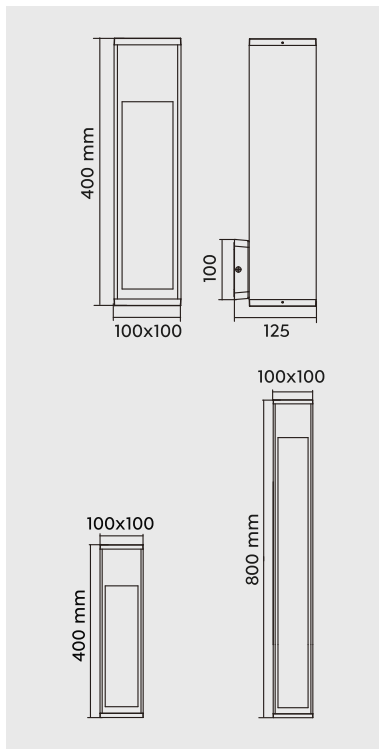

Empfohlen:  
 recommended:

LED GU10, 5 W  
 400 lm, 3.000 K  
 ≥ 120°



**955-50**







# GARONNE

Aluminium Druckguss,  
Naturholz, Glas  
diecast aluminium,  
natural wood, glass  
fonte d'aluminium,  
bois naturel, verre  
gegoten aluminium,  
natuur hout, glas  
aluminio fundido,  
madera natural, vidrio  
pressofusione di alluminio,  
legno naturale, vetro  
fonta aluminiu,  
lemn natural, sticla  
valualumiini,  
luonnonpuu, lasi  
barwione aluminium,  
drewno naturalne, szkło

**30** holzfarbig / Anthrazit ·  
wood coloured / anthracite

Excl. 1 x E27, max. 40 W



IP44

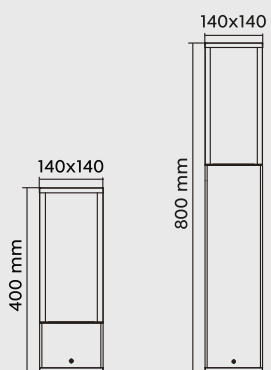
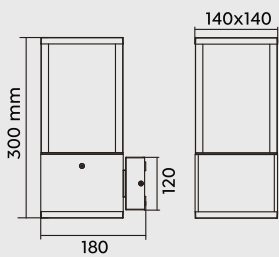

201860130



501860130



401860130

Empfohlen:  
recommended:

Filament LED  
E27, 4 W  
400 lm, 2.700 K



987-400





# GARONNE

Aluminium Druckguss, Glas  
 diecast aluminium, glass  
 fonte d'aluminium, verre  
 gegoten aluminium, glas  
 aluminio fundido, vidrio  
 pressofusione di alluminio, vetro  
 fonta aluminiu, sticla  
 valualumiini, lasi  
 barwione aluminium, szkło

**42** Anthrazit · anthracite

Excl. 1 x E27, max. 40 W

**201860142**

**401860142**

**501860142**

Excl. 2 x E27, max. 40 W

**201860242**

**601860242**



**IP44**



**601860242**



**201860142**



**201860242**



**401860142**



**501860142**

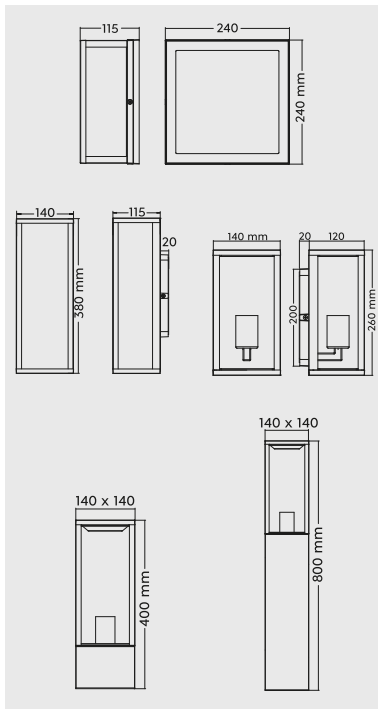

Empfohlen:  
 recommended:

Filament LED  
 E27, 6 W  
 600 lm, 3.000 K



**987-600**

Empfohlen:  
 recommended:

Filament LED  
 E27, 4 W  
 400 lm, 2.700 K



**987-400**





# GARONNE

Aluminium Druckguss, Glas  
 diecast aluminium, glass  
 fonte d'aluminium, verre  
 gegoten aluminium, glas  
 aluminio fundido, vidrio  
 pressofusione di alluminio, vetro  
 fonta aluminiu, sticla  
 valualumiini, lasi  
 barwione aluminium, szkło

**86** zinkfarbig · zinc-colored

Excl. 1 x E27, max. 40 W

**201860186**

**401860186**

**501860186**

Excl. 2 x E27, max. 40 W

**201860286**

**601860286**



**IP44**



**601860286**



**201860186**



**201860286**



**401860186**



**501860186**

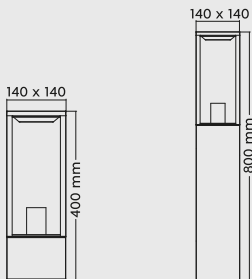
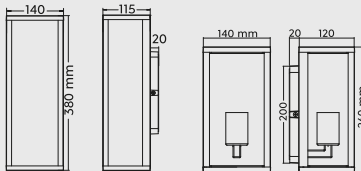
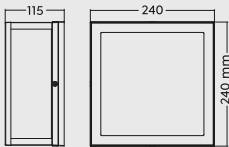

Empfohlen:  
 recommended:

Filament LED  
 E27, 6 W  
 600 lm, 3.000 K



**987-600**

Empfohlen:  
 recommended:

Filament LED  
 E27, 4 W  
 400 lm, 2.700 K



**987-400**



# SAMBESI

Aluminium Druckguss, Acryl  
diecast aluminium, acryl  
fonte d'aluminium, acryl  
gegoten aluminium, acryl  
aluminio fundido, acrílico  
pressofusione di alluminio, acrilico  
fonta aluminiu, acrilic  
valualumiini, akryyli  
barwione aluminium, akryl

**42 Anthrazit · anthracite**

Excl. 1 x E27, max. 28 W

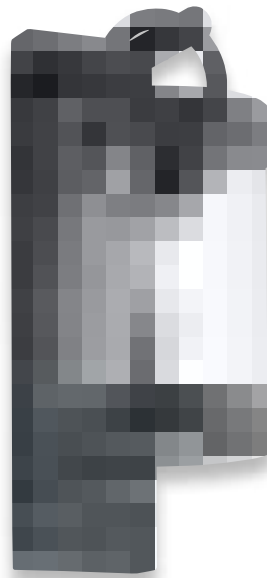
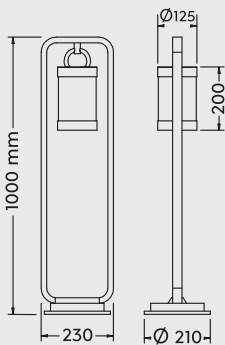
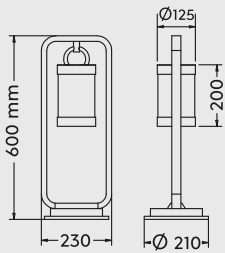
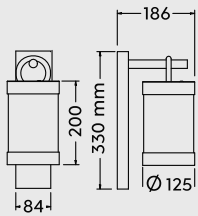

204160142

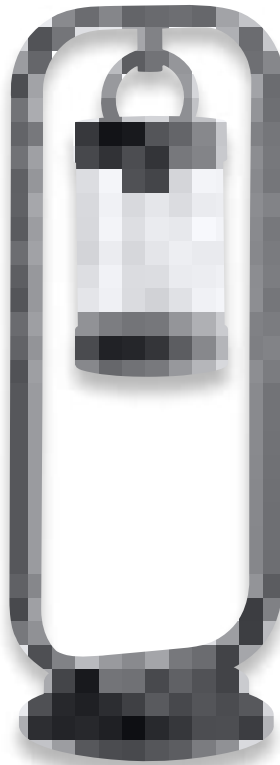

504160142

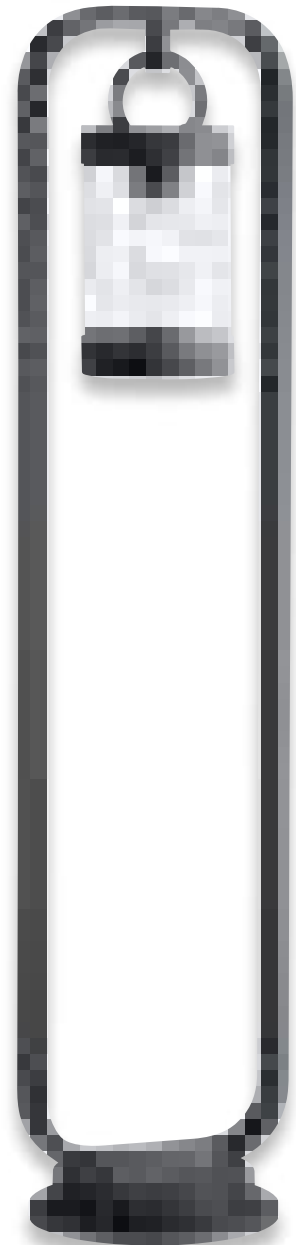

404160142

Empfohlen:  
recommended:

Filament LED  
E27, 4 W  
400 lm, 3.000 K



987-400



Dämmerungssensor per Schalter deaktivierbar

On and off switchable dusk sensor

Décteur de crépuscule commutable

Aan en uit schakelbare schemeringsensor

Sensor de oscuridad conmutable on/off

Sensore crepuscolare commutabile on/off

senzor de lumina/amurg on/off

On/off kytkettävä hämärätunnistin

Czujnik zmierzchowy dezaktywowany przez przełącznika

Aç-kapa anahtarlı karanlık sensörü



# SAMBESI

Aluminium Druckguss, Acryl  
diecast aluminium, acryl  
fonte d'aluminium, acryl  
gegooten aluminium, acryl  
aluminio fundido, acrílico  
pressofusione di alluminio, acrilico  
fonta aluminiu, acrilic  
valualumiini, akryyli  
barwione aluminium, akryl

**31** Weiß matt · white mat

Excl. 1 x E27, max. 28 W

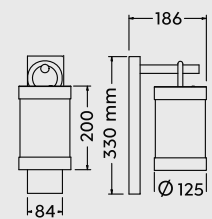

204160131

Empfohlen:  
recommended:

Filament LED  
E27, 4 W  
400 lm, 3.000 K



**987-400**

# SAMBESI

Aluminium Druckguss, Acryl  
 diecast aluminium, acryl  
 fonte d'aluminium, acryl  
 gegoten aluminium, acryl  
 aluminio fundido, acrílico  
 pressofusione di alluminio, acrilico  
 fonta aluminiu, acrilic  
 valualumiini, akryyli  
 barwione aluminium, akryl

**24** rostfarbig · rusty

Excl. 1 x E27, max. 28 W

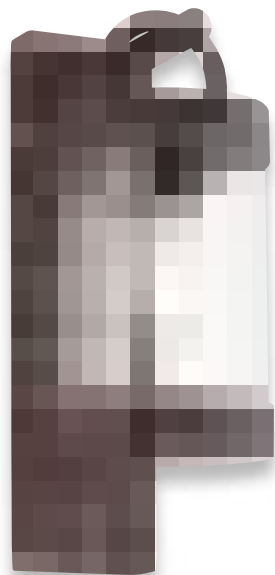

204160124

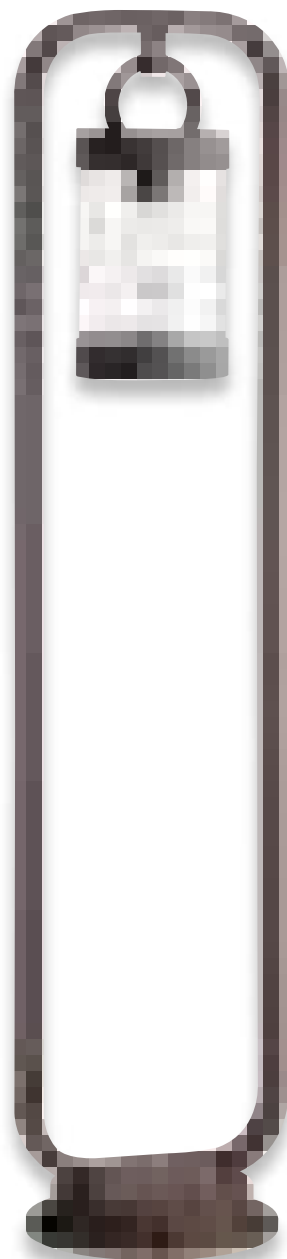

404160124

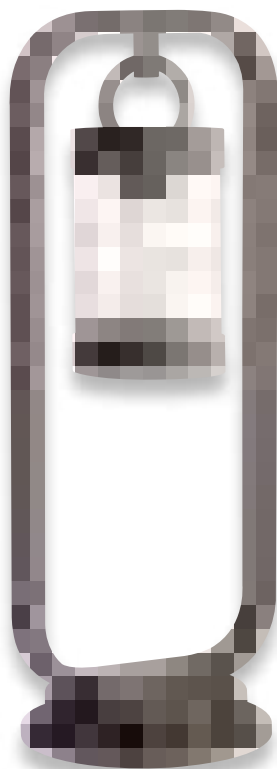

504160124

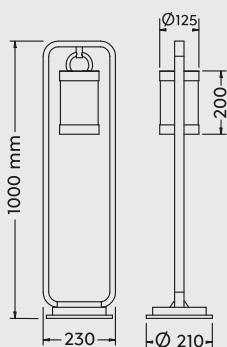
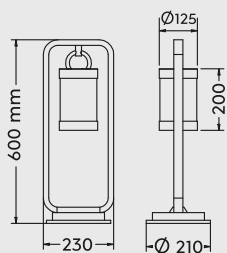
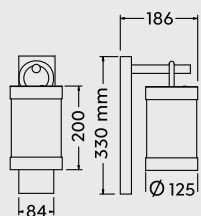

Empfohlen:  
 recommended:

Filament LED  
 E27, 4 W  
 400 lm, 3.000 K



987-400





Dämmerungssensor per Schalter deaktivierbar

On and off switchable dusk sensor

Détecteur de crépuscule commutable

Aan en uit schakelbare schemeringsensor

Sensor de oscuridad conmutable on/off

Sensore crepuscolare commutabile on/off

senzor de lumina/amurg on/off

On/off kytkettävä hämärätunnistin

Czujnik zmierzchowy dezaktywowany przez przełącznika

Aç-kapa anahtarlı karanlık sensörü



# SAMBESI

Aluminium Druckguss, Kunststoff  
 diecast aluminium, plastic  
 fonte d'aluminium, plastique  
 gegoten aluminium, kunststof  
 aluminio fundido, plástico  
 pressofusione di alluminio, plastica  
 fonta aluminiu, plastic  
 valualumiini, muovi  
 barwione aluminium, plastik

**24** rostfarbig · rusty  
**31** Weiß matt · white mat  
**42** Anthrazit · anthracite

Excl. 1 x E27, max. 28 W

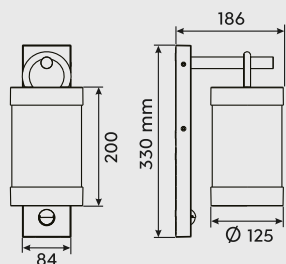

204169131



204169124

Empfohlen:  
 recommended:

Filament LED  
 E27, 4 W  
 400 lm, 3.000 K



987-400

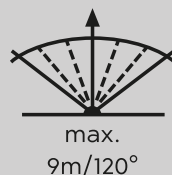

Bewegungssensor  
 Motion sensor  
 Détecteur de mouvement  
 Bewegungssensor  
 Sensor de movimiento  
 Sensore di movimento  
 Senzor de mișcare  
 Liiketunnistin  
 Czujnik ruchu



204169142

# TANARO

Aluminium Druckguss, Acryl  
diecast aluminium, acryl  
fonte d'aluminium, acryl  
gegoten aluminium, acryl  
aluminio fundido, acrílico  
pressofusione di alluminio, acrilico  
fonta aluminiu, acrilic  
valualumiini, akryyli  
barwione aluminium, akryl

**42** Anthrazit · anthracite

Excl. 1 x E27, max. 40 W

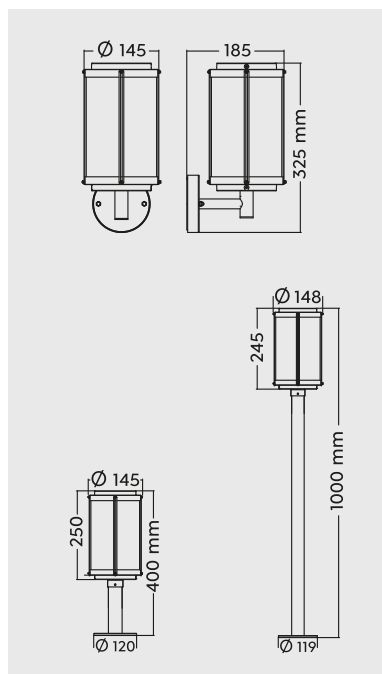

502360142



402360142

Empfohlen:  
recommended:

Filament LED  
E27, 4 W  
400 lm, 3.000 K



987-400





202360142

# TANARO

Aluminium Druckguss, Acryl  
diecast aluminium, acryl  
fonte d'aluminium, acryl  
gegoten aluminium, acryl  
aluminio fundido, acrílico  
pressofusione di alluminio, acrilico  
fonta aluminiu, acrilic  
valualumiini, akryyli  
barwione aluminium, akryl

24 rostfarbig · rusty

Excl. 1 x E27, max. 40 W

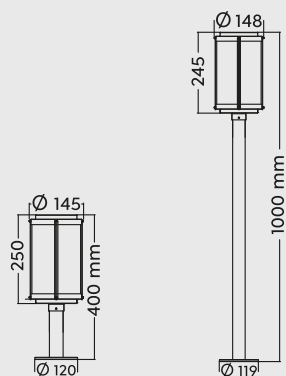
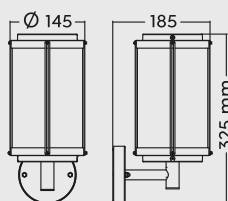

202360124



502360124



402360124

Empfohlen:  
recommended:

Filament LED  
E27, 4 W  
400 lm, 3.000 K



987-400







# BRENTA

Aluminium Druckguss, Glas  
diecast aluminium, glass  
fonte d'aluminium, verre  
gegoten aluminium, glas  
aluminio fundido, vidrio  
pressofusione di alluminio, vetro  
fonta aluminiu, sticla  
valualumiini, lasi  
barwione aluminium, szkło

**24** rostfarbig · rusty

**42** Anthrazit · anthracite

**86** zinkfarbig · zinc-colored

Excl. 1 x E27, max. 40 W



IP44

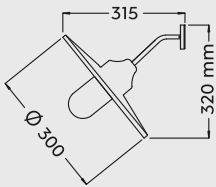

201760124



201760142



201760186

Empfohlen:  
recommended:

Filament LED  
E27, 4 W  
400 lm, 3.000 K



987-400





# BRENTA

Aluminium Druckguss, Glas  
diecast aluminium, glass  
fonte d'aluminium, verre  
gegoten aluminium, glas  
aluminio fundido, vidrio  
pressofusione di alluminio, vetro  
fonta aluminiu, sticla  
valualumiini, lasi  
barwione aluminium, szkło

**24** rostfarbig · rusty

**42** Anthrazit · anthracite

**86** zinkfarbig · zinc-colored

Excl. 1 x E27, max. 40 W



IP44

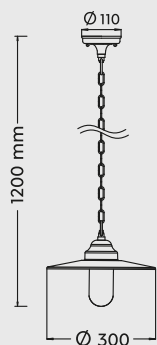

301760124



301760142

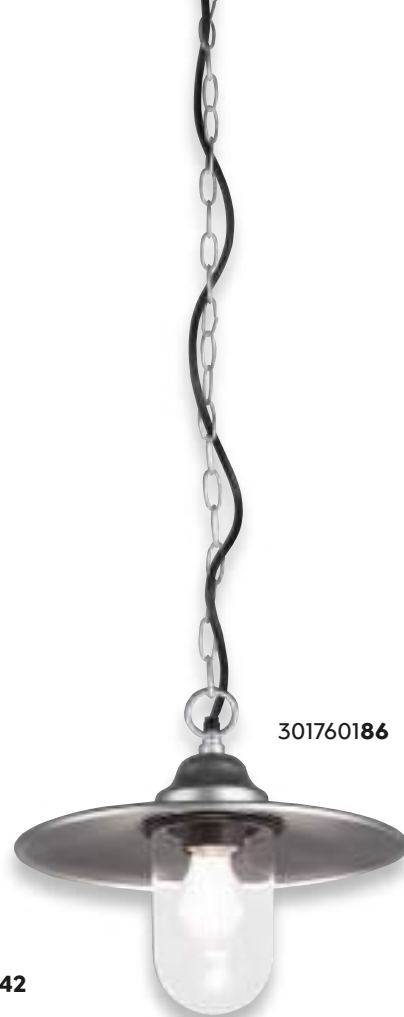

301760186

Empfohlen:  
recommended:

Filament LED  
E27, 4 W  
400 lm, 3.000 K



987-400





# OLONA

Aluminium Druckguss, Glas  
diecast aluminium, glass  
fonte d'aluminium, verre  
gegoten aluminium, glas  
aluminio fundido, vidrio  
pressofusione di alluminio, vetro  
fonta aluminiu, sticla  
valualumiini, lasi  
barwione aluminium, szkło

**24** rostfarbig · rusty

**42** Anthrazit · anthracite

Excl. 1 x E27, max. 20 W



IP23

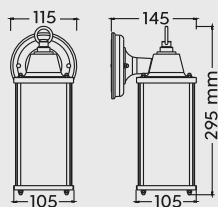

201960124



201960142

Empfohlen:  
recommended:

Filament LED  
E27, 4 W  
400 lm, 3.000 K



987-400



# ARKANSAS

Aluminium Druckguss, Glas  
diecast aluminium, glass  
fonte d'aluminium, verre  
gegoten aluminium, glas  
aluminio fundido, vidrio  
pressofusione di alluminio, vetro  
fonta aluminiu, sticla  
valualumiini, lasi  
barwione aluminium, szkło

**24** rostfarbig · rusty

**42** Anthrazit · anthracite

Excl. 1 x E27, max. 40 W



**IP23**

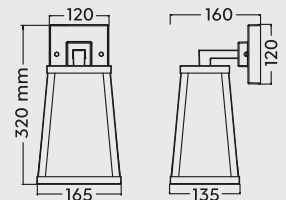

201360142

201360124

Empfohlen:  
recommended:

Filament LED  
E27, 4 W  
400 lm, 3.000 K



987-400

# GRACHT

Aluminium Druckguss, Acryl  
diecast aluminium, acryl  
fonte d'aluminium, acryl  
gegoten aluminium, acryl  
aluminio fundido, acrílico  
pressofusione di alluminio, acrilico  
fonta aluminiu, acrilic  
valualumiini, akryyli  
barwione aluminium, akryl

**28** rostfarbig antik · antique rust

Incl. 1 x SMD-LED, 6 W  
650 lm, 3.000 K

IP54

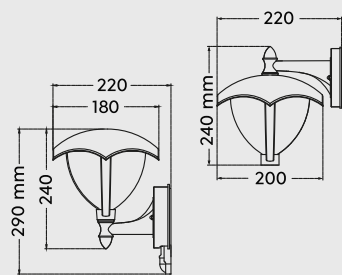

221967128



221969128

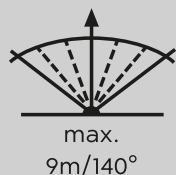

Bewegungssensor  
Motion sensor  
Décteur de mouvement  
Bewegingssensor  
Sensor de movimiento  
Sensore di movimento  
Senzor de mişcare  
Liiketunnistin  
Czujnik ruchu





# DUERO

Aluminium Druckguss, Glas  
diecast aluminium, glass  
fonte d'aluminium, verre  
gegoten aluminium, glas  
aluminio fundido, vidrio  
pressofusione di alluminio, vetro  
fonta aluminiu, sticla  
valualumiini, lasi  
barwione aluminium, szkło

**24** rostfarbig · rusty

**42** Anthrazit · anthracite

**78** betonfarbig · concrete look

Excl. 1 x E27, max. 40 W



IP44

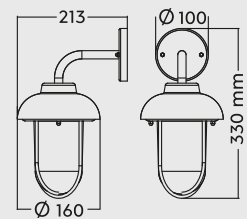

202760142

202760124

202760178

Empfohlen:  
recommended:

Filament LED  
E27, 4 W  
400 lm, 3.000 K



987-400

# KELLY

Aluminium Druckguss, Glas  
diecast aluminium, glass  
fonte d'aluminium, verre  
gegoten aluminium, glas  
aluminio fundido, vidrio  
pressofusione di alluminio, vetro  
fonta aluminiu, sticla  
valualumiini, lasi  
barwione aluminium, szkło

**31** Weiß matt · white mat

**42** Anthrazit · anthracite

Incl. 1 x SMD-LED, 9 W  
900 lm, 3.000 K

IP44

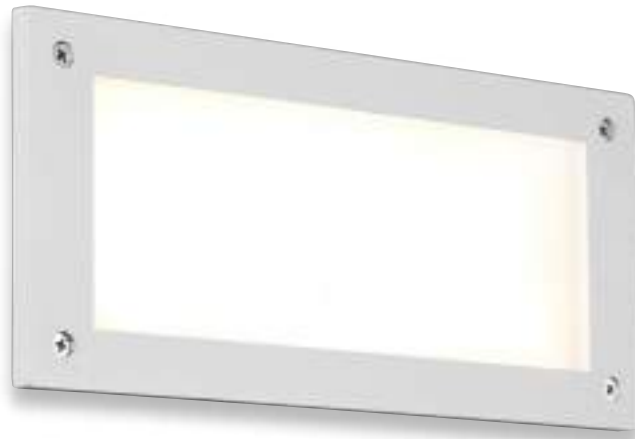
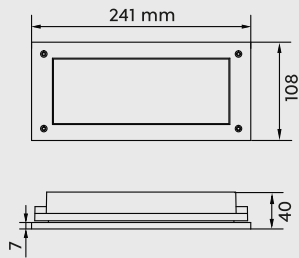

251060131



251060142



# HARDEY



Aluminium Druckguss, Glas  
diecast aluminium, glass  
fonte d'aluminium, verre  
gegoten aluminium, glas  
aluminio fundido, vidrio  
pressofusione di alluminio, vetro  
fonta aluminiu, sticla  
valualumiini, lasi  
barwione aluminium, szkło

**31** Weiß matt · white mat

**42** Anthrazit · anthracite

Incl. 1 x SMD-LED, 9 W  
900 lm, 3.000 K

**IP44**

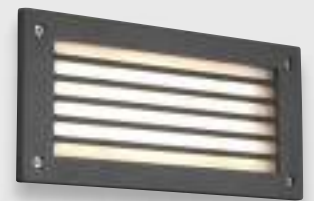
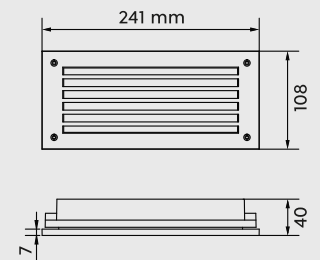

251160142



251160131



Bodeneinbaustrahler  
 Recessed floor lamps  
 Luminaires encastrés de sol  
 grond inbouwspot  
 Lámparas de pie empotradas  
 Incasso Calpestabili  
 Lampi incastrate in podea  
 upotetut maavalot  
 wpuszczzone lampy podłogowe

**07** Nickel matt · nickel mat

Incl. 1 x SMD-LED, 3 W  
 180 lm, 3.000 K

**IP65**

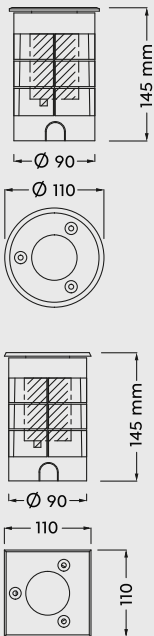

**821660107**



**821669107**



Abstrahlwinkel  
 Emission angle  
 Angle de rayonnement  
 Uitstraalhoek  
 Ángulo de emisión  
 Angolo di emissione  
 Unghiul de emisii  
 Säteilukulma  
 Kąt emisji



Belastbarkeit  
 Resilience  
 Limite de charge  
 Belastbaarheid  
 Resistencia  
 Resistenza  
 Reziștența la solicitare  
 Kuormitettavuus  
 Nośność

# BELAJA



Bodeneinbaustrahler  
Recessed floor lamps  
Luminaire encastrés de sol  
grond inbouwspot  
Lámparas de pie empotradas  
Incasso Calpestabili  
Lampi incastrate in podea  
upotetut maavalot  
wpuszczane lampy podłogowe

**07** Nickel matt · nickel mat

Incl. 1 x SMD-LED, 9 W  
540 lm, 3.000 K

**IP65**

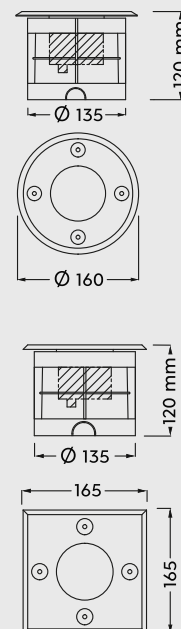

821660207



Abstrahlwinkel  
Emission angle  
Angle de rayonnement  
Uitstraalhoek  
Ángulo de emisión  
Angolo di emissione  
Unghiul de emisii  
Säteilykulma  
Kąt emisji



Belastbarkeit  
Resilience  
Limite de charge  
Belastbaarheid  
Resistencia  
Resistenza  
Rezistența la solicitare  
Kuormitettavuus  
Nośność

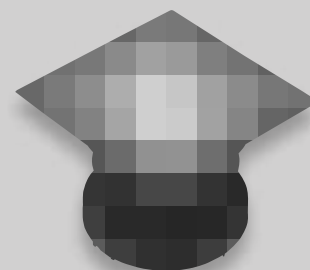

821669207

# NECTOR

Kunststoff  
 plastic  
 plastique  
 kunststof  
 plástico  
 plastica  
 plastic  
 muovi  
 plastik

01 Weiß · white

Incl. RGBW-LED, 8,5 W  
 600 lm, 3.000 - 5.500 K

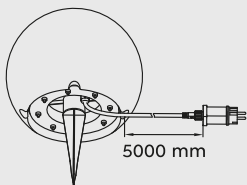
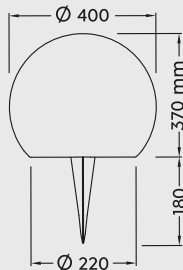
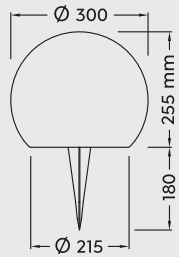

551753001



551754001



+



64.000 **WEISSTÖNE**  
 64,000 **WHITES**



Voreingestellte Lichtmodi · Preset light modes



16 Millionen **FARBEN**  
 16 million **COLORS**



Dynamische Lichtmodi · Dynamic light modes



**WIZ**  
 CONNECTED

trio-lighting.com/wiz

Get your light connected.



WiZ  
APP



Wlan Technologie  
WiFi technology



WiZ  
MOTE

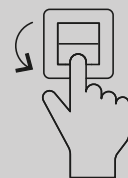

WiZ  
CLICK

# UBANGI

Aluminium Druckguss  
diecast aluminium  
fonte d'aluminium  
gegoten aluminium  
aluminio fundido  
pressofusione di alluminio  
fonta aluminiu  
valualumiini  
barwione aluminium

**42** Anthrazit · anthracite

Excl. 1 x GU10, max. 28 W



IP65



800260142

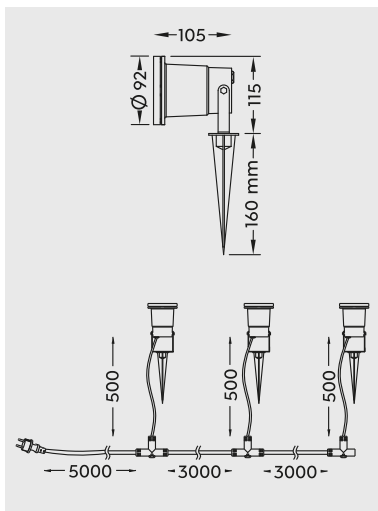

800260342  
**3er Set/3 pc.**

Empfohlen:  
recommended:

LED GU10, 5 W  
400 lm, 3.000 K  
≥ 120°



955-50







# GARTENSTECKDOSEN · GARDEN SOCKETS

Polyresin  
polyresin  
polyresin  
polyresin  
poliresina  
poliestere  
polirasina  
polyresiini  
polyresin

**11** Grau · grey

Zeitschaltuhr · timer  
max. 3.600 W

**9961-11**



max. 3.600 W

**9962-11**

**9963-11**



**9961-11**



**9962-11**

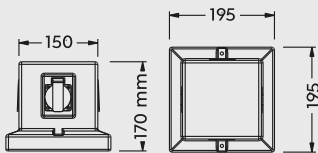
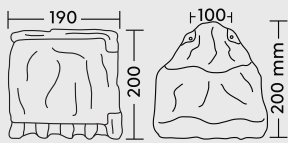

**9963-11**





9964-42

Aluminium Druckguss  
diecast aluminium  
fonte d'aluminium  
gegoten aluminium  
aluminio fundido  
pressofusione di alluminio  
fonta aluminii  
valualumiini  
barwione aluminium

42 Anthrazit · anthracite

max. 3.600 W

IP44

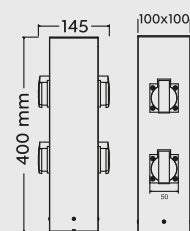

x 4



# UNIVERSAL-ERDSPIESS · GROUND SPIKE

Erdspieß, Edelstahl  
Ground spike, steel  
Piquet de terre, acier  
Aardingspin, staal  
Espiga, acero  
Picchetto, acciaio  
Țepușă pentru pământ, inox  
Maapiikki, teräs  
Žerdz, stal

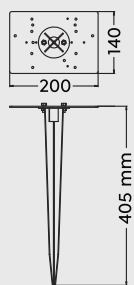

9960-07

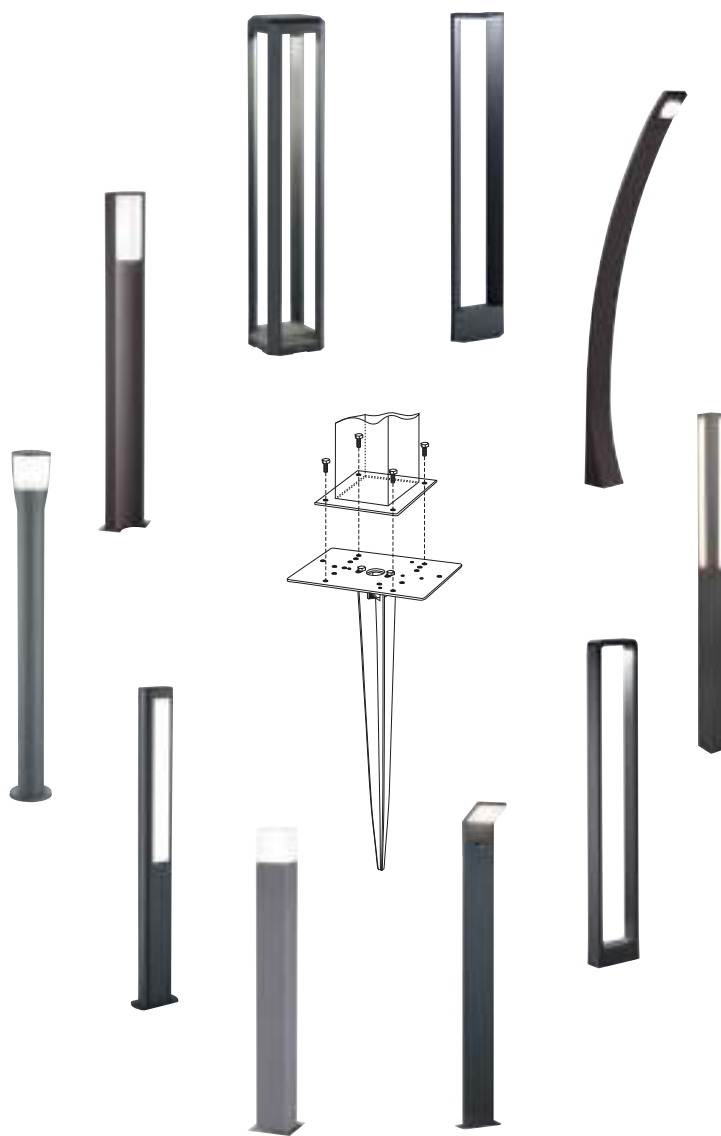

# ECKBEFESTIGUNG · CORNER FASTENING



9965-32



Eckbefestigung, Kunststoff  
Corner fastening, plastic  
Montage en angle, plastique  
Hoekbevestiging, kunststof  
Cantонера, plástico  
Montaggio ad angolo, plastica  
Fixare pentru colț, plastic  
Kulmakiinnike, muovi  
Okucie narożne, plastik

**32** Schwarz matt · black mat

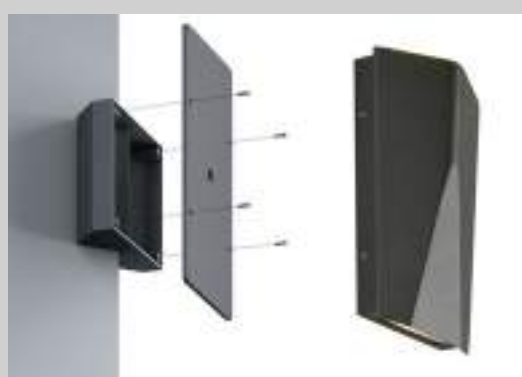
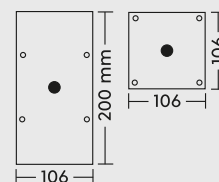





# ARACATI

Nickel matt, Acryl  
nickel mat, acryl  
nickel mat, acryl  
nikkel mat, acryl  
níquel mate, acrílico  
nichel opaco, acrilico  
nichel mat, acrilic  
harjattu teräs, akryyli  
nikiel mat, akryl

**07** Nickel matt · nickel mat

Incl. 1 x SMD-LED, 4 W  
340 lm, 3.000 K

**R28211107**

IP44

Incl. 2 x SMD-LED, 4 W  
2 x 340 lm, 3.000 K

**R28212107**

IP44

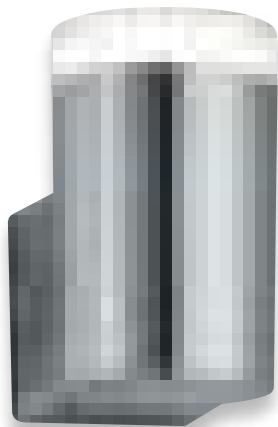
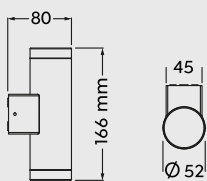
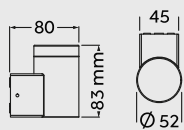

**R28211107**

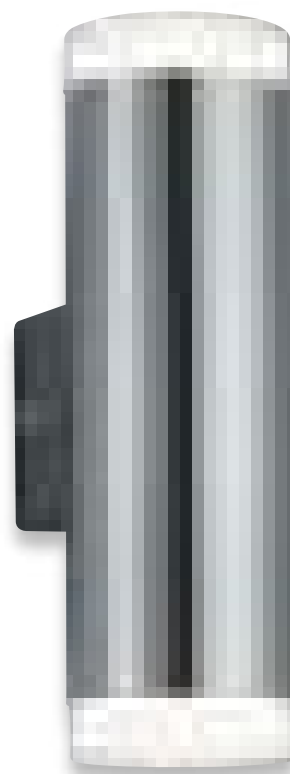

**R28212107**

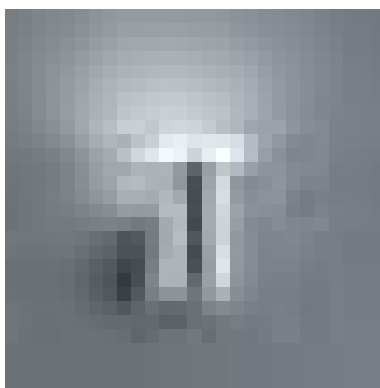





# CORDOBA

Kunststoff  
plastic  
plastique  
kunststof  
plástico  
plastica  
plastic  
muovi  
plastik

**31** Weiß matt · white mat

**32** Schwarz matt · black mat

Incl. 2 x SMD-LED, 2 W  
2 x 200 lm, 3.000 K



R28222631



R28222632

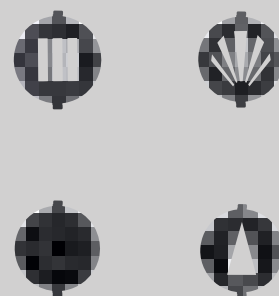
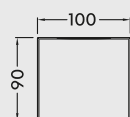
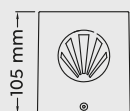

# ROSARIO



R28232631

Kunststoff  
plastic  
plastique  
kunststof  
plástico  
plastica  
plastic  
muovi  
plastik

**31** Weiß matt · white mat

**32** Schwarz matt · black mat

Incl. 2 x SMD-LED, 2 W  
2 x 200 lm, 3.000 K

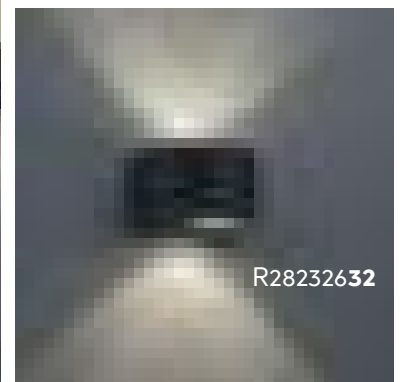
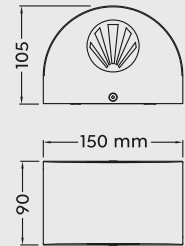

R28232632

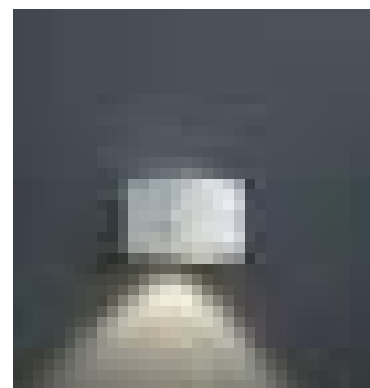
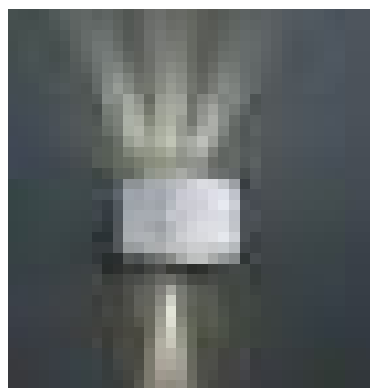

# BOGOTA

Aluminium Druckguss  
diecast aluminium  
fonte d'aluminium  
gegoten aluminium  
aluminio fundido  
pressofusione di alluminio  
fonta aluminiu  
valualumiini  
barwione aluminium

**42** Anthrazit · anthracite

Incl. 2 x SMD-LED, 3 W  
2 x 260 lm, 3.000 K

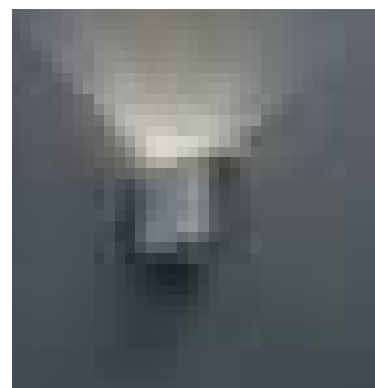
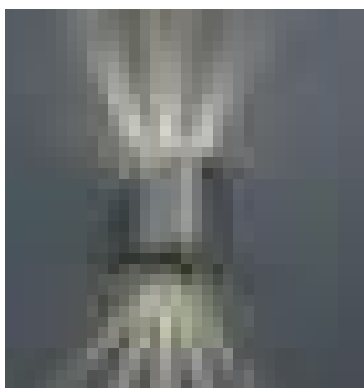
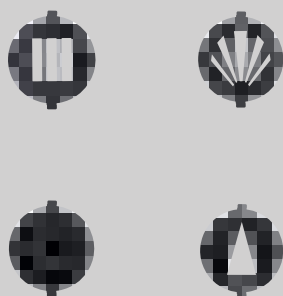
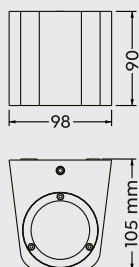

# MOLINA

Aluminium Druckguss, Kunststoff  
diecast aluminium, plastic  
fonte d'aluminium, plastique  
gegoten aluminium, kunststof  
aluminio fundido, plástico  
pressofusione di alluminio, plastica  
fonta aluminiu, plastic  
valualumiini, muovi  
barwione aluminium, plastik

**42** Anthrazit · anthracite

Incl. 2 x SMD-LED, 4,6 W  
2 x 550 lm, 3.000 K

**IP54**

R22052142



R22062142

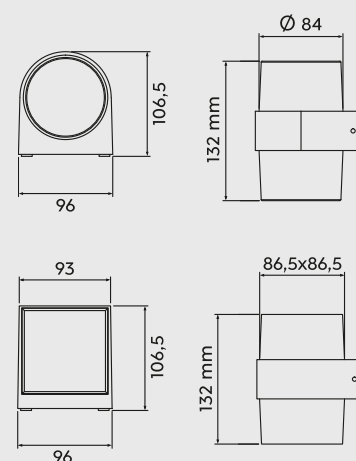

# KENDAL

Kunststoff  
 plastic  
 plastique  
 kunststof  
 plástico  
 plastica  
 plastic  
 muovi  
 plastik

**31** Weiß matt · white mat

**42** Anthrazit · anthracite

Incl. SMD-LED, 12 W  
 1.200 lm, 3.000 K

**R22151131**

**R22151142**

**IP54**

Incl. SMD-LED, 12 W  
 1.000 lm, 3.000 K

**R62151131**

**R62151142**

**IP54**



**R62151131**



**R62151142**



**R22151131**



**R22151142**

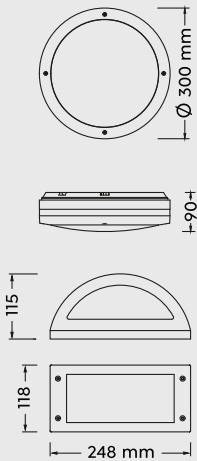



# CAMARO

Kunststoff  
plastic  
plastique  
kunststof  
plástico  
plastica  
plastic  
muovi  
plastik

**31** Weiß matt · white mat

**42** Anthrazit · anthracite

Excl. 1 x E27, max. 12 W

**R60501031**

**R60501042**

Excl. 2 x E27, max. 12 W

**R60502031**

**R60502042**



IP54

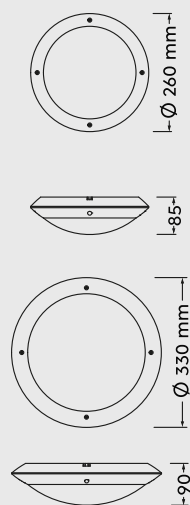

**R60501031**



**R60501042**



**R60502031**



**R60502042**

Empfohlen:  
recommended:

LED E27, 5 W  
400 lm, 3.000 K



**986-60**

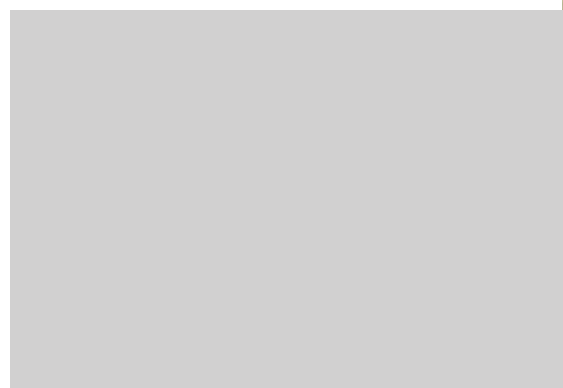







### **Außenbeleuchtung ist viel mehr als nur funktional!**

Dank integriertem Akku sind die transportablen Leuchten flexibel und setzen spannende Akzente im Garten, auf dem Balkon oder der Terrasse - ganz ohne Kabel! Für die richtige Stimmung sorgen zusätzliche Highlights wie RGB-Farbwechsler oder Bluetooth-Funktion für kabelloses Musik hören. Die perfekte Beleuchtung für gemeinsame Abendstunden mit Familie und Freunden.

### **Outdoor lighting is much more than just functional!**

Integrated rechargeable batteries lets you flexibly use these easily transportable lights to accent your garden, balcony or terrace in an exciting way, all without any cables! Additional highlights like an RGB colour wheels and Bluetooth for streaming music wirelessly provide just the right mood. The perfect lighting for spending evening hours with family and friends.

### **L'éclairage extérieur est bien plus que simplement fonctionnel !**

Grâce à la batterie rechargeable intégrée, les lampes transportables sont flexibles et mettent des accents excitants dans le jardin, sur le balcon ou la terrasse –

sans aucun câble ! D'autres fonctions marquantes garantissent une bonne ambiance, telles que le changeur de couleurs RVB ou la fonction Bluetooth pour l'écoute de musique sans fil. L'éclairage parfait pour les soirées partagées avec la famille et les amis.

### **Buitenverlichting is veel meer dan enkel nuttig!**

Dankzij de geïntegreerde accu zijn de verplaatsbare lampen flexibel en zorgen voor mooie accenten in de tuin, op het balkon of op het terras, en dat helemaal zonder kabel! Voor de juiste stemming zorgen extra hoogtepunten zoals de RGB-kleurenwisselaar of Bluetooth-functie om draadloos muziek te beluisteren. De perfecte verlichting om 's avonds aangenaam te vertoeven met vrienden en familie.

### **¡La iluminación exterior es mucho más que algo funcional!**

Gracias a la batería integrada, las luces transportables son flexibles y aportan puntos de atención excitantes al jardín, al balcón o a la terraza - ¡y sin ningún tipo de cables! Se consigue el ambiente adecuado con otras características especiales adicionales como el modificador de color RGB o la función Bluetooth para escuchar música sin cables. La iluminación perfecta para pasar la tarde con la familia y los amigos.



### L'illuminazione esterna è molto più che funzionale!

Grazie alla batteria ricaricabile integrata, le lampade portatili sono flessibili e creano accenti emozionanti in giardino, sul balcone o sulla terrazza - senza cavi! Ulteriori punti di forza come il cambiacolori RGB o la funzione Bluetooth per l'ascolto di musica senza fili assicurano il giusto feeling. L'illuminazione perfetta per le ore serali da trascorrere insieme alla famiglia e agli amici.

### Iluminarea exterioară este mult mai mult decât funcțională!

Datorită acumulatorului integrat, lămpile transportabile sunt flexibile și oferă un aspect atrăgător în grădină, pe balcon sau pe terasă - fără cablu! Atmosfera potrivită este asigurată de jocurile suplimentare de lumină cum ar fi schimbarea culorilor RGB sau funcția Bluetooth pentru a asculta muzică fără cablu. Iluminarea perfectă pentru orele de seară cu familia și prietenii.

### Ulkovalaistus on paljon muutakin kuin vain toimintaa!

Integroidun ladattavan akun ansiosta siirrettävät valaisimet ovat joustavia ja muodostavat jännittäviä korostuksia puutarhaan, parvekkeelle tai terassille - ilman kaapeleita! Lisäkorostukset, kuten RGB-väinvaihtajat tai Bluetooth-toiminto langattomaan musiikin kuuntelun, takaavat oikean ilmapiirin. Täydellinen valaistus illanviettoon yhdessä perheen ja ystävien kanssa.

### Oświetlenie zewnętrzne to znacznie więcej niż tylko funkcjonalność!

Dzięki akumulatorowi przenośne lampy są elastyczne w ustawieniu i tworzą ekscytujące akcenty w ogrodzie, na balkonie lub tarasie - bez żadnych kabli! Odpowiedni nastrój zapewnią dodatkowe urządzenia, takie jak zmieniacze kolorów RGB lub funkcja Bluetooth do bezprzewodowego słuchania muzyki. Doskonałe oświetlenie wspólnych wieczorów z rodziną i przyjaciółmi.

# PALMAS

Kunststoff  
 plastic  
 plastique  
 kunststof  
 plástico  
 plastica  
 plastic  
 muovi  
 plastik

**01** Weiß · white

Incl. 1 x RGBW-LED, 1,5 W  
 45 lm, 3.000 K

**R55101101**

Incl. 1 x RGBW-LED, 3 W  
 90 lm, 3.000 K

**R45101101**

Incl. 1 x RGBW-LED, 4,5 W  
 120 lm, 3.000 K

**R45101901**

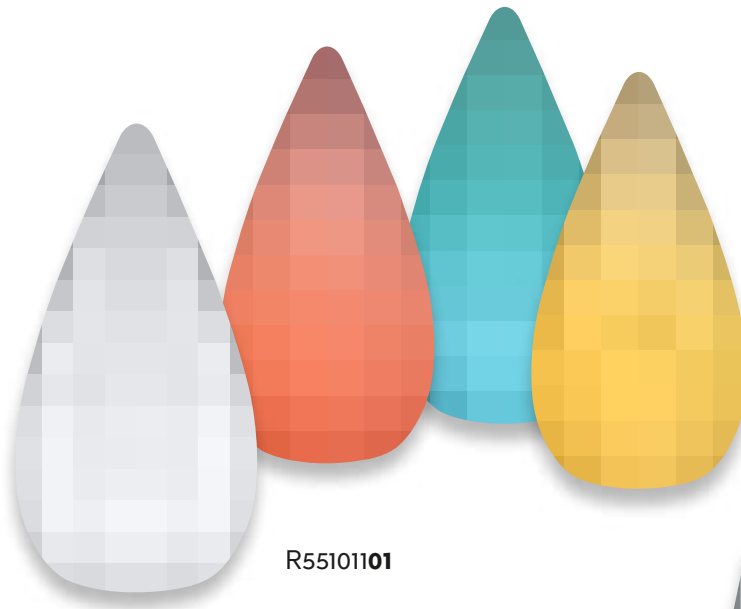

**R55101101**

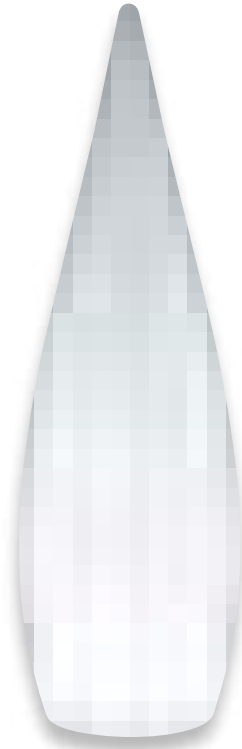

**R45101101**



**R45101901**

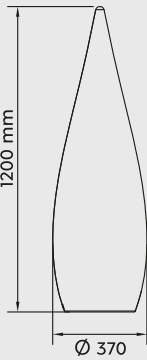
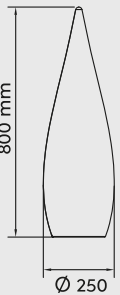
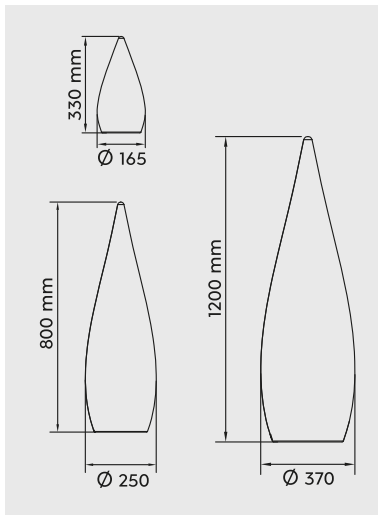

RGBW Farbwechsler  
 RGBW Colorchanging  
 Changement de couleur RGBW  
 RGBW Kleurverandering  
 Cambio de color RGBW  
 Cambia colore RGBW  
 Schimbator de culoare RGBW  
 Värinvaihto RGB  
 Zmieniający kolor RGBW



Akkubetrieb  
 Rechargeable battery operated  
 Fonctionnement sur batteries rechargeable  
 Oplaadbare accu  
 Batería recargable  
 Batteria Ricaricabile  
 Operabil prin baterie reincarcabila  
 Ladattava akku  
 Akumulator zasilany bateryjnie  
 Şarj edilebilir pilli

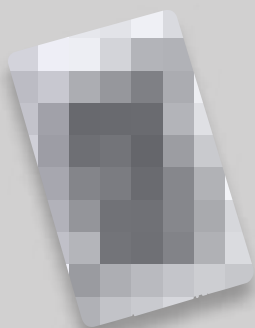



Ladezeit  
Charging time  
Temps de charge  
Oplaaftijd  
Tiempo de carga  
Tempo di carica  
Timp de incarcare  
Latausaika  
Czas ładowania



Leuchtdauer  
Luminous period  
Durée d'éclairage  
Brandtijd  
Tiempo de iluminación  
Tempo di durata  
Perioada de iluminare  
Valaistusaika  
Czas świecenia

# BERMUDA

Kunststoff  
plastic  
plastique  
kunststof  
plástico  
plastica  
plastic  
muovi  
plastik

01 Weiß · white

Incl. 1 x RGBW-LED, 1 W  
35 lm, 3.000 K

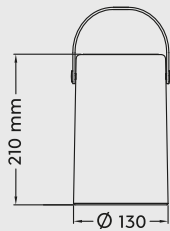

## LIGHT & SOUND



R55060101



Bluetooth Lautsprecher  
Bluetooth loudspeaker  
Haut-parleur bluetooth  
Bluetooth luidspreker  
Altavoz de bluetooth  
Altoparlante bluetooth  
Difuzor Bluetooth  
Bluetooth-kaiutin  
Głośnik Bluetooth



Ladezeit  
Charging time  
Temps de charge  
Oplaaftijd  
Tiempo de carga  
Tempo di carica  
Timp de incarcare  
Latausaika  
Czas ładowania



Leuchtdauer  
Luminous period  
Durée d'éclairage  
Brandtijd  
Tiempo de iluminación  
Tempo di durata  
Perioada de iluminare  
Valaistus aika  
Czas świecenia

# JAMAICA



R55086101

Kunststoff  
plastic  
plastique  
kunststof  
plástico  
plastica  
plastic  
muovi  
plastik

**01** Weiß · white

Incl. 1 x RGBW-LED, 2,5 W  
25 lm, 3.000 K

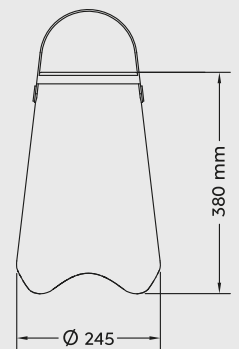

## LIGHT & SOUND

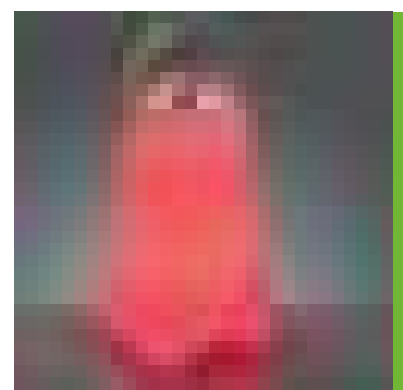
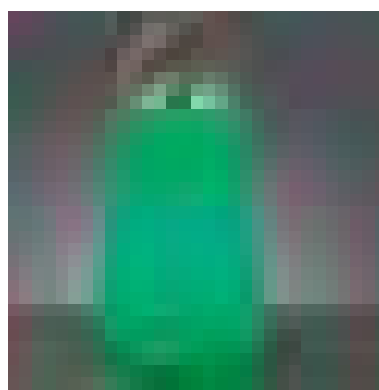
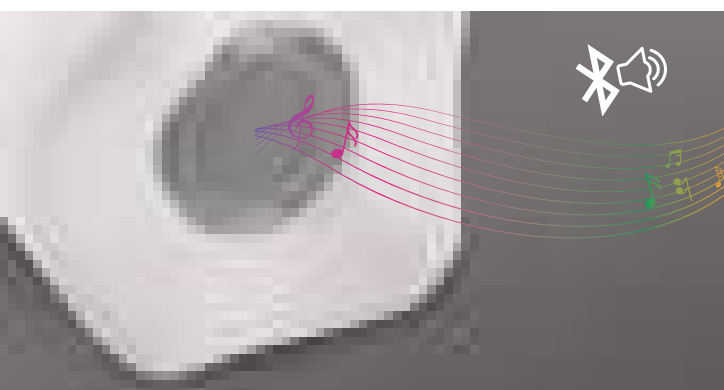

# ARUBA

Kunststoff  
plastic  
plastique  
kunststof  
plástico  
plastica  
plastic  
muovi  
plastik

01 Weiß · white

Incl. 1 x RGBW-LED, 1 W  
70 lm, 3.000 K

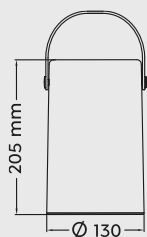

R57080101



RGBW Farbwechsler  
RGBW Colorchanging  
Changement de couleur RGBW  
RGBW Kleurverandering  
Cambio de color RGBW  
Cambia colore RGBW  
Schimbator de culoare RGBW  
Värinvaihto RGB  
Zmieniający kolor RGBW



USB Anschluss mit Ladefunktion  
Recharging USB connection  
Entrée USB de rechargement  
Opladende USB aansluiting  
Conexión USB de recarga  
Connessione USB di ricarica  
Conexiune USB reîncărcare  
Lataaminen USB-liitäntä  
Ładowania USB połączenie  
șarj USB baġlantı



# HAITI



R57090101

Kunststoff  
plastic  
plastique  
kunststof  
plástico  
plastica  
plastic  
muovi  
plastik

01 Weiß · white

Incl. 1 x RGBW-LED, 1 W  
70 lm, 3.000 K

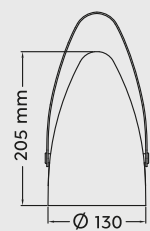

Ladezeit  
Charging time  
Temps de charge  
Oplaadtijd  
Tiempo de carga  
Tempo di carica  
Timp de incarcare  
Latausaika  
Czas ładowania



Leuchtdauer  
Luminous period  
Durée d'éclairage  
Brandtijd  
Tiempo de iluminación  
Tempo di durata  
Perioada de iluminare  
Valaistus aika  
Czas świecenia

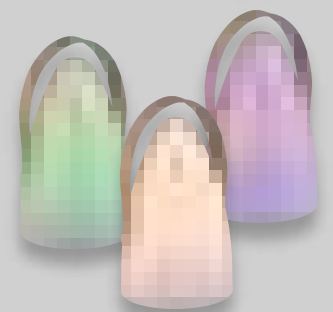

# HAWAII

Kunststoff  
plastic  
plastique  
kunststof  
plástico  
plastica  
plastic  
muovi  
plastik

01 Weiß · white

Incl. 1 x RGB-LED, 1,5 W  
60 lm, 3.000 K

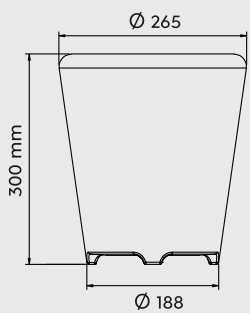
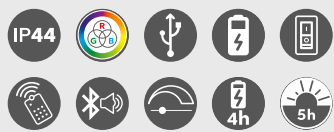

LIGHT & SOUND



R55096101



Bluetooth Lautsprecher  
Bloutooth loudspeaker  
Haut-parleur bluetooth  
Bluetooth luidspreker  
Altavoz de bluetooth  
Altoparlante bluetooth  
Difuzor Bluetooth  
Bluetooth-kaiutin  
Głośnik Bluetooth



Ladezeit  
Charging time  
Temps de charge  
Oplaatijd  
Tiempo de carga  
Tempo di carica  
Timp de incarcare  
Latausaika  
Czas ładowania



Leuchtdauer  
Luminous period  
Durée d'éclairage  
Brandtijd  
Tiempo de iluminación  
Tempo di durata  
Perioada de iluminare  
Valaistusaika  
Czas świecenia

Kunststoff  
plastic  
plastique  
kunststof  
plástico  
plastica  
plastic  
muovi  
plastik

01 Weiß · white

Incl. 1 x SMD-LED, 1,5 W  
130 lm, 3.000 K

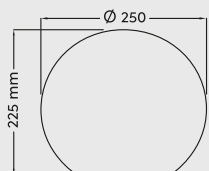
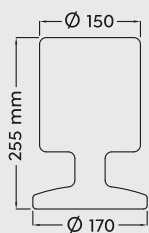

BARBADOS

R57010101



BAHAMAS

R57020101



Ladezeit  
Charging time  
Temps de charge  
Oplaadtijd  
Tiempo de carga  
Tempo di carica  
Timp de incarcare  
Latausaika  
Czas ładowania



Leuchtdauer  
Luminous period  
Durée d'éclairage  
Brandtijd  
Tiempo de iluminación  
Tempo di durata  
Perioada de iluminare  
Valaistusaika  
Czas świecenia



**DORA**  
R57051101

**LORA**  
R57071101

Kunststoff  
plastic  
plastique  
kunststof  
plástico  
plastica  
plastic  
muovi  
plastik

**01** Weiß · white

Incl. 1 x SMD-LED, 1,5 W  
90 lm, 3.000 K

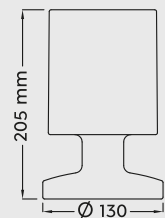
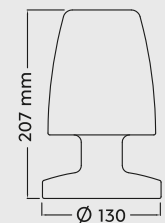

Akkubetrieb  
Rechargeable battery operated  
Fonctionnement sur batteries rechargeable  
Oplaadbare accu  
Batería recargable  
Batteria Ricaricabile  
Operabil prin baterie reincarcabila  
Ladattava akku  
Akumulator zasilany bateryjnje



USB Anschluss mit Ladefunktion  
Recharging USB connection  
Entrée USB de rechargement  
Opladende USB aansluiting  
Conexión USB de recarga  
Connessione USB di ricarica  
Conexiune USB reîncărcare  
Lataaminen USB-liitäntä  
Ładowania USB połączenie

# DOMINGO

Metall, Kunststoff  
 metal, plastic  
 metale, plastique  
 metaal, kunststof  
 metal, plástico  
 metallo, plastica  
 metal, plastic  
 metalli, muovi  
 metal, plastik

**42** Anthrazit · anthracite

Incl. 1 x SMD-LED, 2 W  
 150 lm, 3.000 K

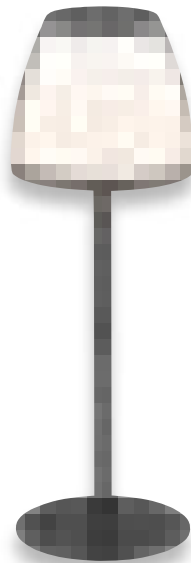
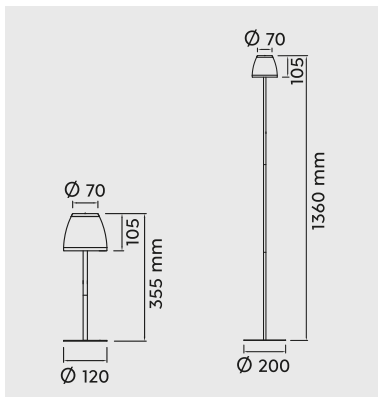

R52096142

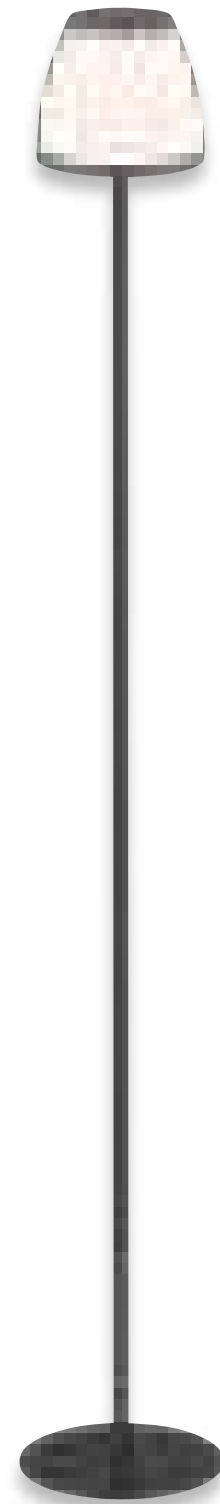

R42096142

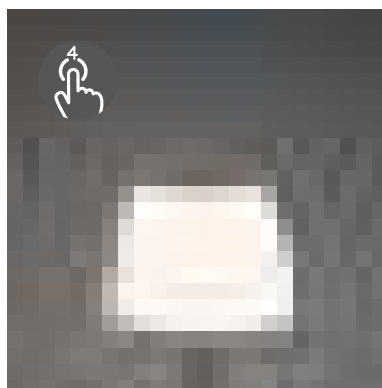
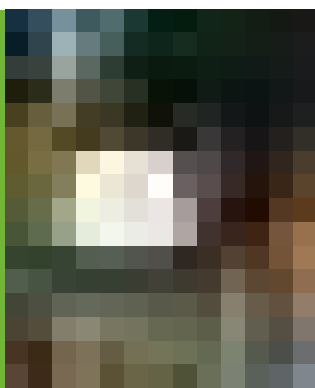

Ladezeit  
 Charging time  
 Temps de charge  
 Oplaadtijd  
 Tiempo de carga  
 Tempo di carica  
 Timp de incarcare  
 Latausaika  
 Czas ładowania



Leuchtdauer  
 Luminous period  
 Durée d'éclairage  
 Brandtijd  
 Tiempo de iluminación  
 Tempo di durata  
 Perioada de iluminare  
 Valaistusaika  
 Czas świecenia

# LENNON



R52176101

Kunststoff  
plastic  
plastique  
kunststof  
plástico  
plastica  
plastic  
muovi  
plastik

**01** Weiß · white  
**02** Schwarz · black

Incl. 1 x SMD-LED, 2 W  
200 lm, 3.000 K

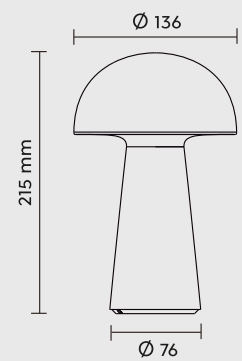

R52176102



Akkubetrieb  
Rechargeable battery operated  
Fonctionnement sur batteries rechargeable  
Oplaadbare accu  
Batería recargable  
Batteria Ricaricabile  
Operabil prin baterie reincarcabila  
Ladattava akku  
Akumulator zasilany bateryjnie



USB Anschluss mit Ladefunktion  
Recharging USB connection  
Entrée USB de rechargement  
Opladende USB aansluiting  
Conexión USB de recarga  
Connessione USB di ricarica  
Conexiune USB reîncărcare  
Lataaminen USB-liitäntä  
ładowania USB połączenie

# BOLO

Kunststoff  
plastic  
plastique  
kunststof  
plástico  
plastica  
plastic  
muovi  
plastik

01 Weiß · white

Excl. 1 x E27, max. 23 W

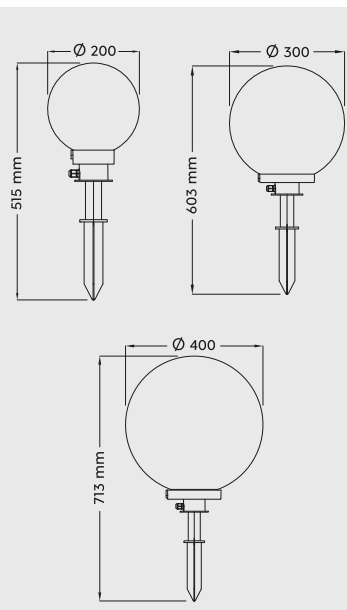

R57043001



R57042001



R57044001

Empfohlen:  
recommended:

LED E27, 10 W  
806 lm, 3.000 K



R988-90









### **Sonne Tanken!**

Solarleuchten nutzen ausschließlich die Kraft der Sonne um Licht zu erzeugen. Dabei sind sie extrem umwelt-schonend, sparsam und gleichermaßen praktisch, da sie weder Steckdosen noch einen Anschluss ans Stromnetz benötigen. In Kombination mit moderner LED-Technik bieten Solarleuchten ideales Licht für Haus und Garten.

### **Soak up the sun!**

Solar lamps exclusively use the power of the sun to generate light. At the same time they are extremely environmentally friendly and economical as well as practical, as they need neither sockets nor a connection to the mains supply. In combination with modern LED technology, solar lamps provide an ideal light for home and garden.

### **Faites le plein de soleil !**

Les lampes solaires utilisent exclusivement l'énergie du soleil pour générer de la lumière. En même temps, elles sont extrêmement écologiques, économiques et tout aussi pratiques, car elles ne nécessitent ni prise de courant ni raccordement au réseau électrique. En combinaison avec la technologie LED moderne, les lampes solaires fournissent une lumière idéale pour la maison et le jardin.

### **Doe zon op!**

Zonnelampen maken uitsluitend gebruik van de kracht van de zon om licht te produceren. Daarbij zijn ze extreem milieuvriendelijk, zuinig en in gelijke mate praktisch, omdat ze noch een stopcontact noch een aansluiting op het stroomnet nodig hebben. In combinatie met moderne ledtechniek bieden zonnelampen ideaal licht voor huis en tuin.

### **¡Disfrute del sol!**

Las luces solares usan exclusivamente la energía del sol para generar luz. Al mismo tiempo, son extremadamente ecológicas, económicas e igualmente prácticas, y no necesitan ni enchufes ni conexión a la corriente. En combinación con las modernas técnicas LED, las luces solares ofrecen una luz ideal para la casa y el jardín.



### **Prendete un po' di sole!**

Le lampade solari utilizzano esclusivamente la potenza del sole per generare luce. Allo stesso tempo sono estremamente rispettose dell'ambiente, economiche e pratiche in quanto non richiedono né presa di corrente, né un collegamento alla rete elettrica. In combinazione con la moderna tecnologia LED, le lampade solari forniscono una luce ideale per la casa e il giardino.

### **Alimentați cu soare!**

Lămpile solare se folosesc în exclusivitate de energia soarelui pentru a genera lumină. În acest context sunt extrem de ecologice, economice și practice în același timp, deoarece nu necesită nici prize și nici conectarea la o rețea electrică. În combinație cu tehnologia modernă LED, lămpile solare oferă lumina ideală pentru casă și grădină.

### **Ajattele aurinkoa!**

Aurinkovalaisimet käyttävät auringon energiaa valon tuottamiseen. Samalla ne ovat erittäin ympäristöystävällisiä, taloudellisia ja myös käytännöllisiä, koska ne eivät vaadi pistorasioita tai liitäntää sähköverkkoon. Yhdessä modernin LED-tekniikan kanssa aurinkovalaisimet tarjoavat ihanteellisen valaistuksen kotiin ja puutarhaan.

### **Nałapać energii słonecznej!**

Lampy solarne wykorzystują moc słońca do generowania światła. Są one przy tym niezwykle przyjazne dla środowiska, ekonomiczne i jednocześnie praktyczne, ponieważ nie wymagają gniazd ani podłączenia do sieci elektrycznej. W połączeniu z nowoczesną technologią LED lampy solarne zapewniają idealne oświetlenie domu i ogrodu.

# POSADAS

Kunststoff  
 plastic  
 plastique  
 kunststof  
 plástico  
 plastica  
 plastic  
 muovi  
 plastik

**42** Anthrazit · anthracite

Incl. 1 x SMD-LED, 4,5 W  
 290 lm, 3.000 K



R22251142

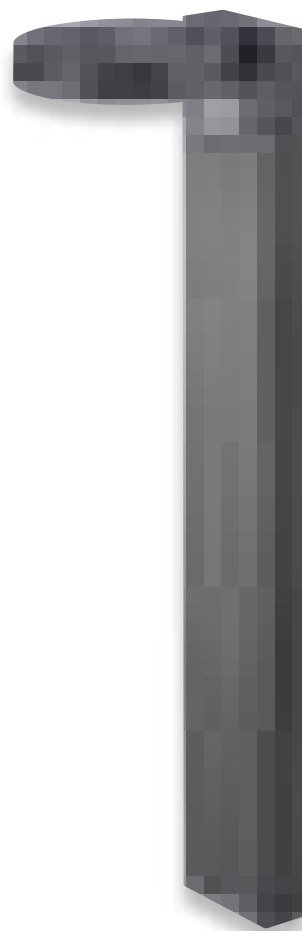
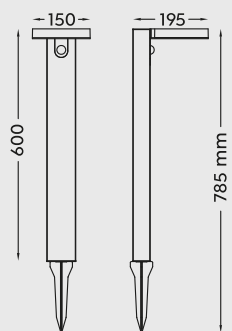
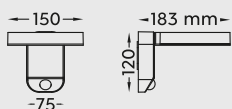

R42251142

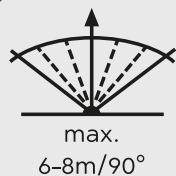

Ladezeit  
 Charging time  
 Temps de charge  
 Oplaadtijd  
 Tiempo de carga  
 Tempo di carica  
 Timp de incarcare  
 Latausaika  
 Czas ładowania



Leuchtdauer  
 Luminous period  
 Durée d'éclairage  
 Brandtijd  
 Tiempo de iluminación  
 Tempo di durata  
 Perioada de iluminare  
 Valaistus aika  
 Czas świecenia



# ESQUEL

Kunststoff  
plastic  
plastique  
kunststof  
plástico  
plastica  
plastic  
muovi  
plastik

**42** Anthrazit · anthracite

Incl. 1 x SMD-LED, 4,5 W  
290 lm, 3.000 K

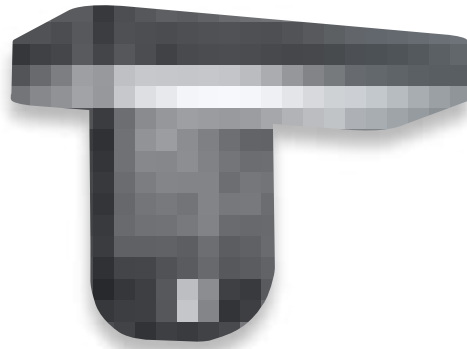
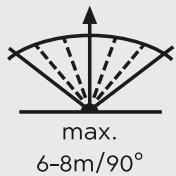
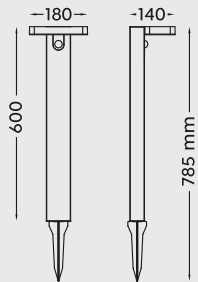
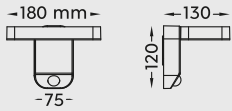

R22261142

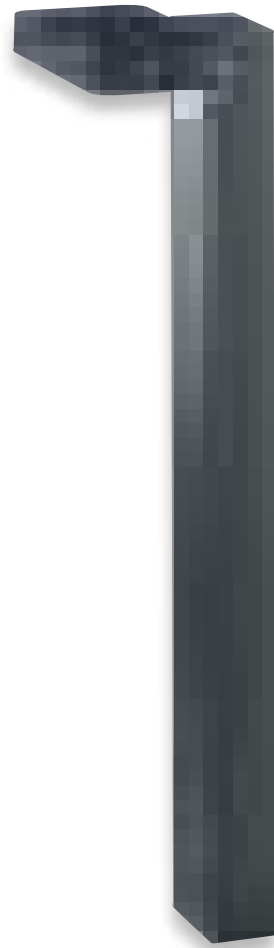

R42261142



Ladezeit  
Charging time  
Temps de charge  
Oplaadtijd  
Tiempo de carga  
Tempo di carica  
Timp de incarcare  
Latausaika  
Czas ładowania



Leuchtdauer  
Luminous period  
Durée d'éclairage  
Brandtijd  
Tiempo de iluminación  
Tempo di durata  
Perioada de iluminare  
Valaistusaika  
Czas świecenia

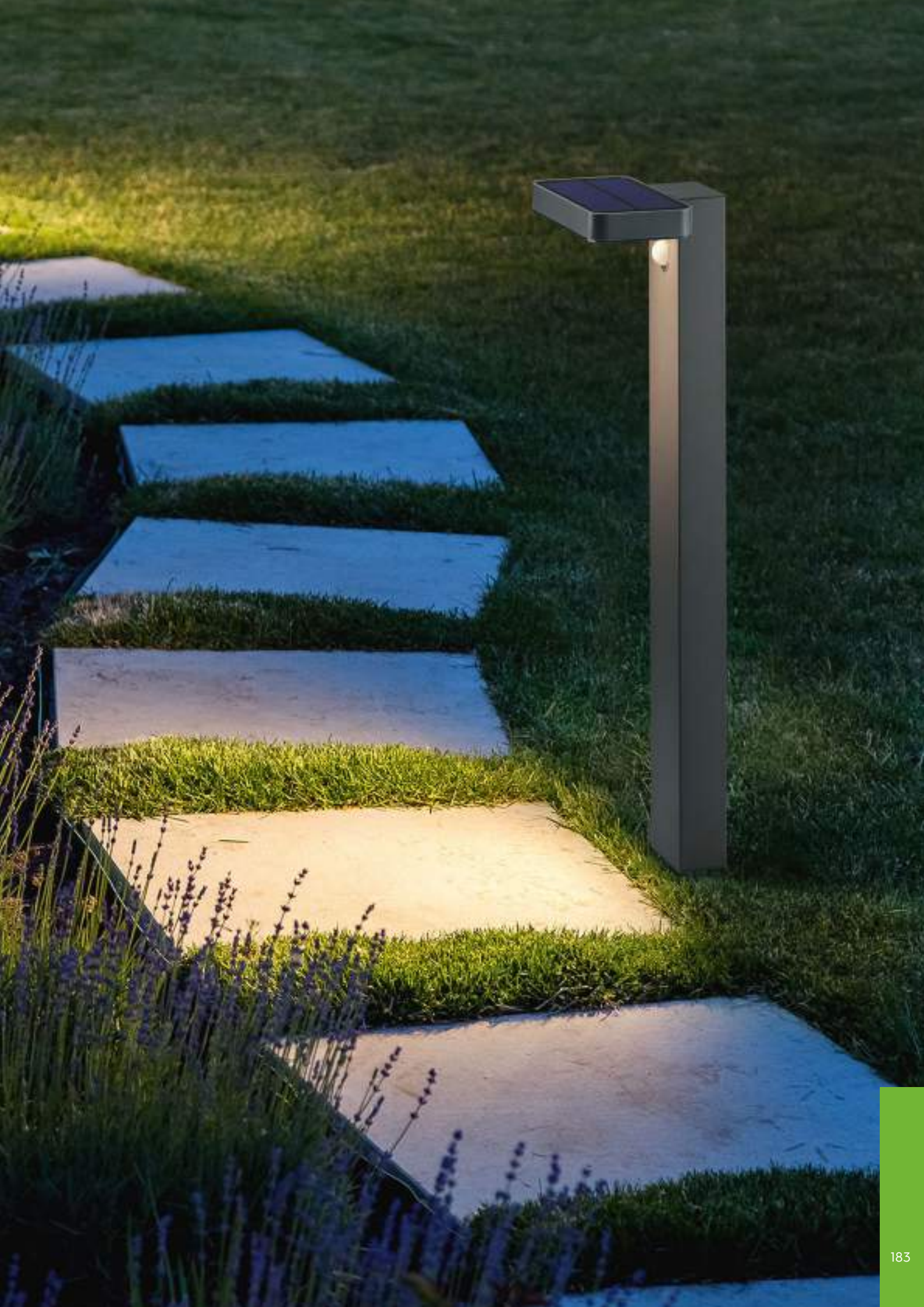

Kunststoff  
 plastic  
 plastique  
 kunststof  
 plástico  
 plastica  
 plastic  
 muovi  
 plastik

42 Anthrazit · anthracite

Incl. 1 x SMD-LED, 5 W  
 200 lm, 3.000 K

R22241142



Incl. 1 x SMD-LED, 4,8 W  
 340 lm, 3.000 K

R22281142

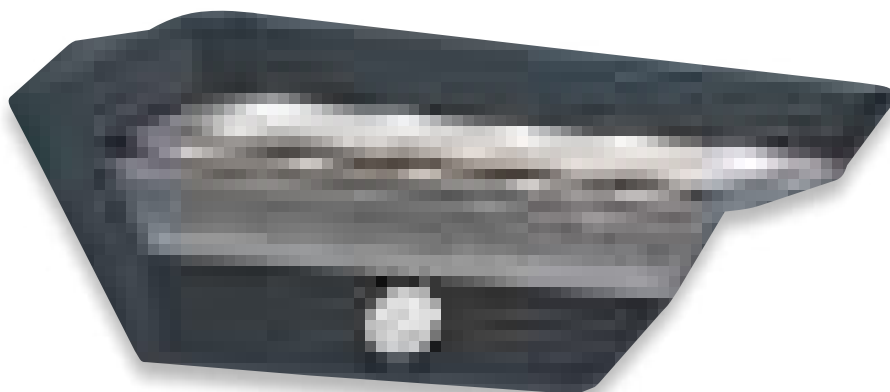
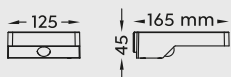

## MENDOZA

R22241142

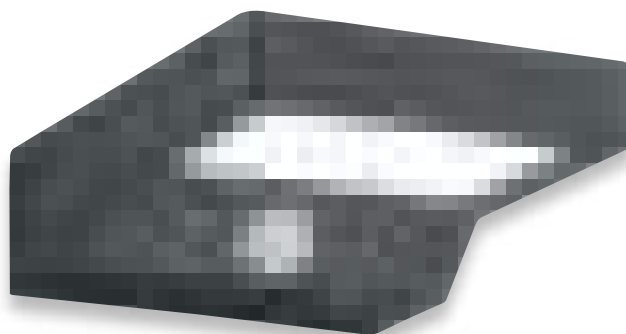

## FOMOSA

R22281142



max.  
 5-8m/90°



Ladezeit  
 Charging time  
 Temps de charge  
 Oplaadtijd  
 Tiempo de carga  
 Tempo di carica  
 Timp de încarcare  
 Latausaika  
 Czas ładowania



# SALTA

Metall, Acryl  
metal, acryl  
metale, acryl  
metaal, acryl  
metal, acrílico  
metallo, acrilico  
metal, acrilic  
metalli, akryyli  
metal, akryl

**07** Nickel matt · nickel mat

**42** Anthrazit · anthracite

Incl. 1 x SMD-LED, 3 W  
165 lm, 3.000 K



R22231107

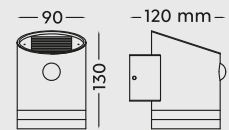

R22231142



Leuchtdauer  
Luminous period  
Durée d'éclairage  
Brandtijd  
Tiempo de iluminación  
Tempo di durata  
Perioada de iluminare  
Valaistusaika  
Czas świecenia

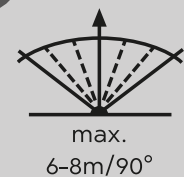

# MINEROS

Kunststoff  
plastic  
plastique  
kunststof  
plástico  
plastica  
plastic  
muovi  
plastik

01 Weiß · white

11 Grau · grey

Incl. SMD-LED, 0,02 W

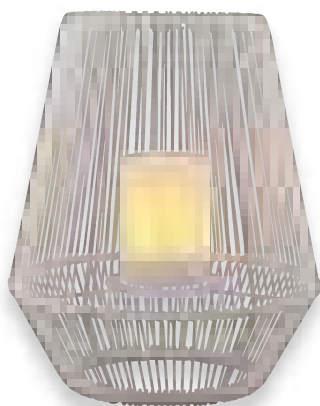

R55256101

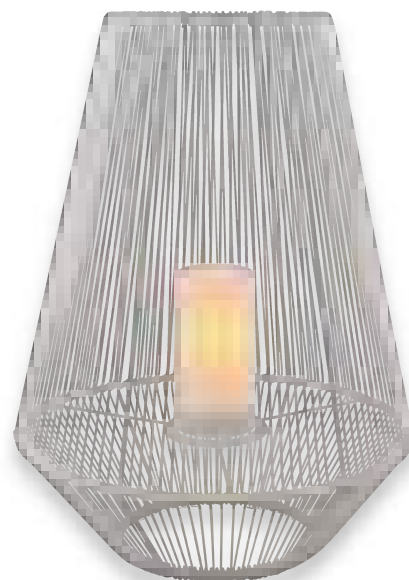

R55256901

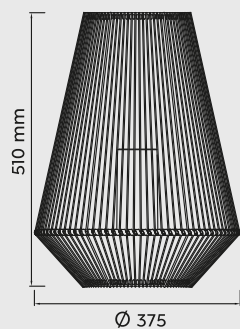
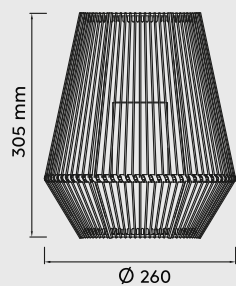

R55256911



R55256111



Ladezeit  
Charging time  
Temps de charge  
Oplaadtijd  
Tiempo de carga  
Tempo di carica  
Timp de incarcare  
Latausaika  
Czas ładowania



Leuchtdauer  
Luminous period  
Durée d'éclairage  
Brandtijd  
Tiempo de iluminación  
Tempo di durata  
Perioada de iluminare  
Valaistus aika  
Czas świecenia



Dämmerungssensor  
Dusk sensor  
Détecteur de crépuscule  
Schemeringsensor  
Sensor de oscuridad  
Sensore crepuscolare  
Sensor de lumina/amurg  
Hämärätunnistin  
Czujnik zmierzchowy



Flammen-Effekt  
Flame effect  
Effet de flamme  
Vlammeneffect  
Efecto de llamas  
Effetto fiamma  
Efect de flacăără  
Liekkitehoste  
Efekt płomienia

# VINTO

Kunststoff  
plastic  
plastique  
kunststof  
plástico  
plastica  
plastic  
muovi  
plastik

44 Beige · fawn

Incl. SMD-LED, 0,1 W  
R55276144



Incl. SMD-LED, 0,2 W  
R55276944

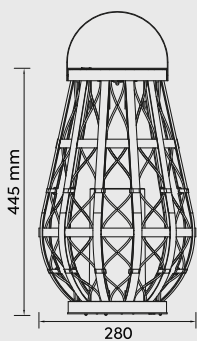
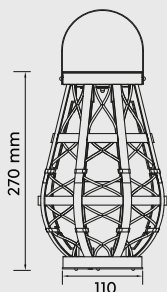

R55276144



R55276944



Ladezeit  
Charging time  
Temps de charge  
Oplaadtijd  
Tiempo de carga  
Tempo di carica  
Timp de incarcare  
Latausaika  
Czas ładowania



Leuchtdauer  
Luminous period  
Durée d'éclairage  
Brandtijd  
Tiempo de iluminación  
Tempo di durata  
Perioada de iluminare  
Valaistus aika  
Czas świecenia



# MONTERO

Metall  
metal  
metale  
metaal  
metal  
metallo  
metal  
metalli  
metal

**31** Weiß matt · white mat

**88** Silber antik · antique silver

Incl. SMD-LED, 0,1 W

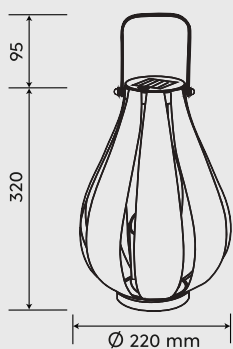

R55266131



R55266188



Ladezeit  
Charging time  
Temps de charge  
Oplaadtijd  
Tiempo de carga  
Tempo di carica  
Timp de incarcare  
Latausaika  
Czas ładowania



Leuchtdauer  
Luminous period  
Durée d'éclairage  
Brandtijd  
Tiempo de iluminación  
Tempo di durata  
Perioada de iluminare  
Valaistus aika  
Czas świecenia

Kunststoff  
 plastic  
 plastique  
 kunststof  
 plástico  
 plastica  
 plastic  
 muovi  
 plastik

**42** Anthrazit · anthracite

Incl. SMD-LED, 0,02 W

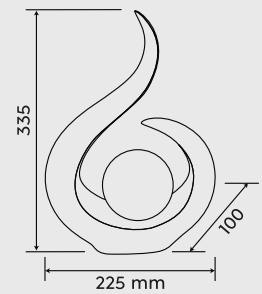

R55296142



Dämmerungssensor  
 Dusk sensor  
 Détecteur de crépuscule  
 Schemeringsensor  
 Sensor de oscuridad  
 Sensore crepuscolare  
 Senzor de lumina/amurg  
 Hämärätunnistin  
 Czujnik zmierzchowy



Flammen-Effekt  
 Flame effect  
 Effet de flamme  
 Vlammeffect  
 Efecto de llamas  
 Effetto fiamma  
 Efect de flacără  
 Liekkitehoste  
 Efekt płomienia

# CAMIRI

Metall  
metal  
metale  
metaal  
metal  
metallo  
metal  
metalli  
metal

**62** Kupfer antik · antique copper

**88** Silber antik · antique silver

Incl. SMD-LED, 0,02 W

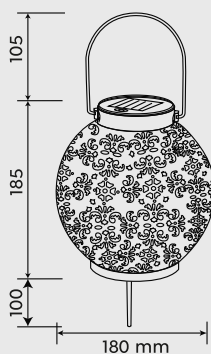

R55286188



R55286162



Ladezeit  
Charging time  
Temps de charge  
Oplaadtijd  
Tiempo de carga  
Tempo di carica  
Timp de incarcare  
Latausaika  
Czas ładowania



Leuchtdauer  
Luminous period  
Durée d'éclairage  
Brandtijd  
Tiempo de iluminación  
Tempo di durata  
Perioada de iluminare  
Valaistusaika  
Czas świecenia





R55316132

Metall  
metal  
metale  
metaal  
metal  
metallo  
metal  
metalli  
metal

**32** Schwarz matt · black mat

Incl. SMD-LED, 0,01 W

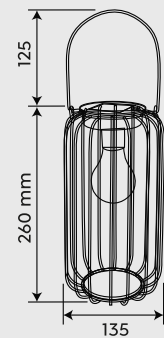

Dämmerungssensor  
Dusk sensor  
Décteur de crépuscule  
Schemeringsensor  
Sensor de oscuridad  
Sensore crepuscolare  
Sensor de lumina/amurg  
Hämärätunnistin  
Czujnik zmierzchowy



Flammen-Effekt  
Flame effect  
Effet de flamme  
Vlammeneffect  
Efecto de llamas  
Effetto fiamma  
Efect de flacără  
Liekkitehoste  
Efekt płomienia

Kunststoff  
 plastic  
 plastique  
 kunststof  
 plástico  
 plastica  
 plastic  
 muovi  
 plastik

**26** Braun · brown  
**32** Schwarz matt · black mat

Incl. SMD-LED, 0,1 W  
**R55196126**



Incl. SMD-LED, 0,2 W  
**R55146132**



**CARMELO**  
 R55196126

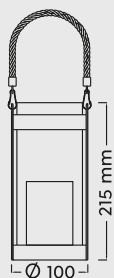

**MINAS**  
 R55146132



Flammen-Effekt  
 Flame effect  
 Effet de flamme  
 Vlammeneffect  
 Efecto de llamas  
 Effetto fiamma  
 Efect de flacără  
 Liekkitehoste  
 Efekt płomienia





R55136132

Metall, Kunststoff  
 metal, plastic  
 metale, plastique  
 metaal, kunststof  
 metal, plástico  
 metallo, plastica  
 metal, plastic  
 metalli, muovi  
 metal, plastik

**32** Schwarz matt · black mat

Incl. SMD-LED, 0,2 W

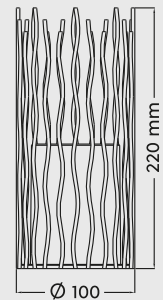

Ladezeit  
 Charging time  
 Temps de charge  
 Oplaadtijd  
 Tiempo de carga  
 Tempo di carica  
 Timp de încarcare  
 Latausaika  
 Czas ładowania



Leuchtdauer  
 Luminous period  
 Durée d'éclairage  
 Brandtijd  
 Tiempo de iluminación  
 Tempo di durata  
 Perioada de iluminare  
 Valaistusaika  
 Czas świecenia

Kunststoff  
plastic  
plastique  
kunststof  
plástico  
plastica  
plastic  
muovi  
plastik

**32** Schwarz matt · black mat

Incl. SMD-LED, 0,24 W

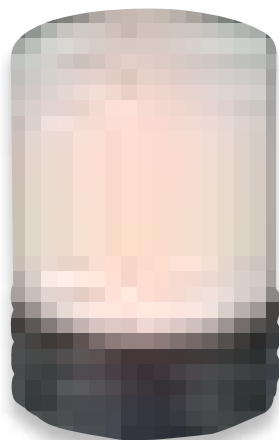

**PARRAL**  
R55166132

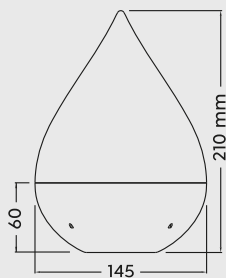
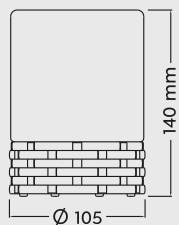

**CALDERA**  
R55156132



Flammen-Effekt  
Flame effect  
Effet de flamme  
Vlammeneffect  
Efecto de llamas  
Effetto fiamma  
Efect de flacără  
Liekkitehoste  
Efekt płomienia





R55176132

Metall, Kunststoff  
metal, plastic  
metale, plastique  
metaal, kunststof  
metal, plástico  
metallo, plastica  
metal, plastic  
metalli, muovi  
metal, plastik

**32** Schwarz matt · black mat

Incl. SMD-LED, 0,1 W

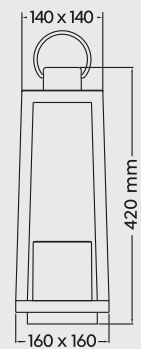

Ladezeit  
Charging time  
Temps de charge  
Oplaadtijd  
Tiempo de carga  
Tempo di carica  
Timp de incarcare  
Latausaika  
Czas ładowania



Leuchtdauer  
Luminous period  
Durée d'éclairage  
Brandtijd  
Tiempo de iluminación  
Tempo di durata  
Perioada de iluminare  
Valaistusaika  
Czas świecenia

# MELO

Kunststoff  
plastic  
plastique  
kunststof  
plástico  
plastica  
plastic  
muovi  
plastik

01 Weiß · white

Incl. 1 x RGBW-LED, 0,5 W

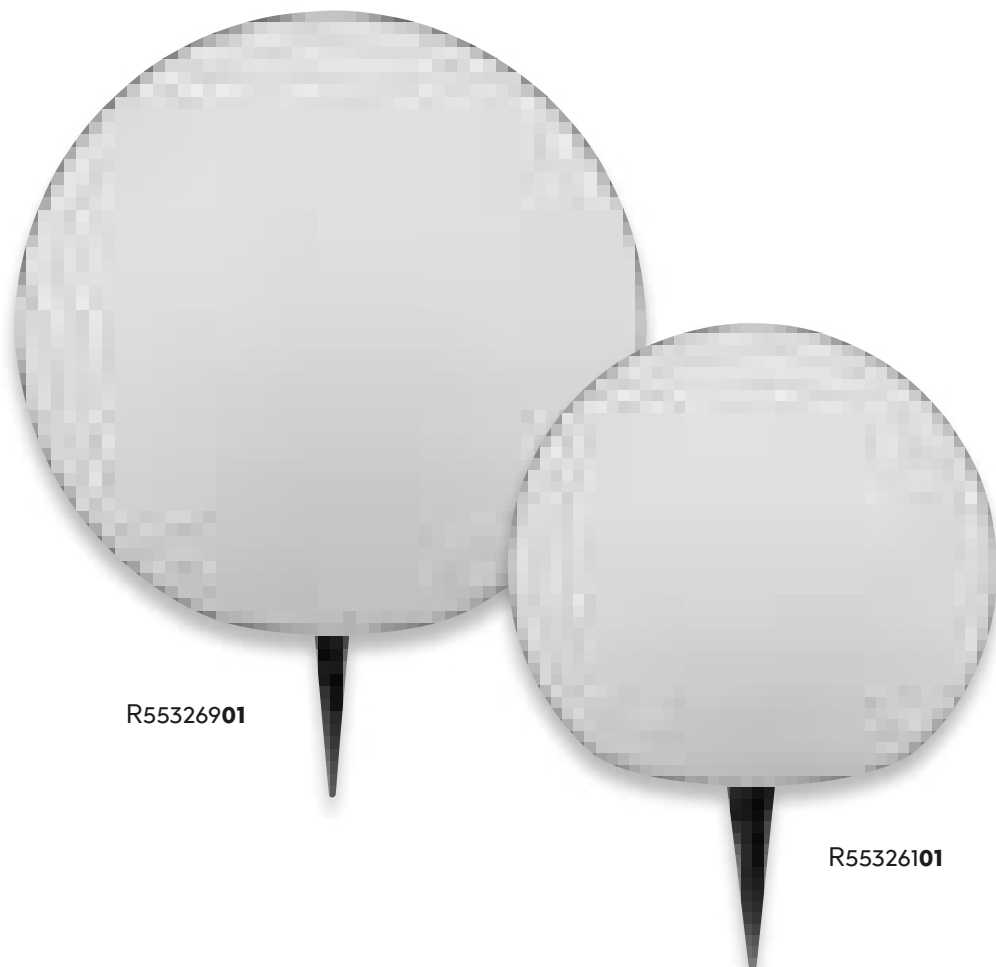
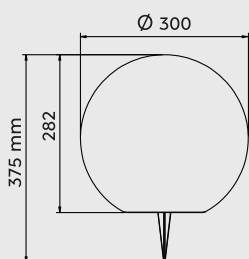
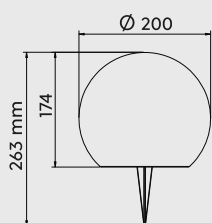

R55326901

R55326101



RGBW Farbwechsler  
RGBW Colorchanging  
Changement de couleur RGBW  
RGBW Kleurverandering  
Cambio de color RGBW  
Cambia colore RGBW  
Schimbator de culoare RGBW  
Värvaihto RGB  
Zmieniający kolor RGBW



Ladezeit  
Charging time  
Temps de charge  
Oplaaftijd  
Tiempo de carga  
Tempo di carica  
Timp de incarcare  
Latausaika  
Czas ładowania



Leuchtdauer  
Luminous period  
Durée d'éclairage  
Brandtijd  
Tiempo de iluminación  
Tempo di durata  
Perioada de iluminare  
Valaistusaika  
Czas świecenia

# Produkteigenschaften · Features

Caractéristiques · Kenmerken · Acabados ·  
Caratteristiche · Caracteristici · Ominaisuudet · Cechy



Schalter · Switch  
Interrupteur · Schakelaar · Interruptor ·  
Interruttore · Intrerupator · Kytkin ·  
Przełącznik



Fernbedienung · Remote control  
Commande à distance · Afstandsbediening ·  
Mando a distancia · Comando a distanza ·  
Telecomanda · Kauko-ohjain · Pilot



Integrierter Dimmer · Integrated dimmer  
Variateur intégré · Geïntegreerde dimmer ·  
Regulador integrado · Dimmer integrato ·  
Variator de lumina integrat · Integroitu himmennin ·  
Wbudowany ściemniacz



RGBW Farbwechsler · RGBW Colorchanging  
Changement de couleur RGBW ·  
RGBW Kleurverandering · Cambio de color RGBW ·  
Cambia colore RGBW · Schimbator de culoare  
RGBW · Värvivaihto RGB · Zmieniający kolor RGBW



RGB Farbwechsler · RGB Colorchanging  
Changement de couleur RGB ·  
RGB Kleurverandering · Cambio de color RGB ·  
Cambia colore RGB · Schimbator de culoare RGB ·  
Värvivaihto RGB · Zmieniający kolor RGB



Schwenkbar · Tilttable  
Pivotant · Draaibaar · Pivotante ·  
Girevole · Pivotant · Suunnattava · Skräpny



Steckdose · Plug  
Prise · Stekker · Enchufe · Spina ·  
Priza · Katkaisin · Gniazdko



Bewegungssensor · Motion sensor  
Décteur de mouvement · Bewegungssensor ·  
Sensor de movimiento · Sensore di movimento ·  
Senzor de mişcare · Liiketunnistin · Czujnik ruchu



Dämmerungssensor · Dusk sensor  
Décteur de crépuscule · Schemeringsensor ·  
Sensor de oscuridad · Sensore crepuscolare ·  
Senzor de lumina/amurg · Hämärätunnistin ·  
Czujnik zmierzchowy



4 fach TOUCH · 4 level Touch function  
Interrupteur tactile 4 niveaux ·  
Touch schakelaar 4 niveaus · Función Táctil 4 nivel ·  
Interruttore touch 4 livelli · Intrerupator tactil  
4 nivele · Kosketuskäyttöinen 4 taso ·  
Funkcja dotykowa 4 poziomy



Lichtfarbe stufenlos einstellbar ·  
Light color infinitely variable  
Couleur de lumière infiniment variable ·  
Lichtkleur traploos instelbaar · Color de luz  
infinitamente variable · Colore della luce  
infinitamente variabile · Culoare lumină infinit  
variabilă · Valon väri portaattomasti ·  
Jasny kolor bezstopniowo



Up and down Beleuchtung ·  
Up and Down lighting  
Point lumineux en haut et en bas · Lichtpunt boven  
en onder · Luz de arriba y abajo · Luce su e giù ·  
Sus și în jos lumina · Ylös ja alas valoa ·  
W górę iw dół światło



Ohne Leuchtmittel · Lamp(s) excluded  
Sans ampoule(s) · Zonder lichtbron(nen) ·  
Sin bombilla(s) · Lampadina Esclusa · Fara bec (s) ·  
Ilman polttimo (s) · Bez żarówki (s)



Timer · Timer  
Minuterie · Timer · Temporizador · Timer ·  
Temporizator · Ajastin · Timer



Helligkeit einstellbar · Adjustable light level  
Niveau d'éclairage ajustable · Instelbaar  
lichtniveau · Nivel de luz ajustable · Livello di luce  
regolabile · Nivelul de lumina reglabil · Säädettävä  
valo taso · Regulowana jasność światła



Bluetooth Lautsprecher ·  
Bloutooth loudspeaker  
Haut-parleur bluetooth · Bluetooth luidspreker ·  
Altavoz de bluetooth · Altoparlante bluetooth ·  
Difuzor Bluetooth · Bluetooth-kaiutin ·  
Głośnik Bluetooth



USB Anschluss · USB connection  
Entrée USB · USB aansluiting · Conexión USB ·  
Connessione USB · Conexiune USB ·  
USB-liitäntä · Połączenie USB



USB Anschluss mit Ladefunktion ·  
Recharging USB connection  
Entrée USB de rechargement · Opladende USB  
aansluiting · Conexión USB de recarga ·  
Connessione USB di ricarica · Conexiune USB  
reîncărcare · Lataaminen USB-liitäntä ·  
ładowania USB połączenie





Solar · Solar  
Solaire · Solair · Solar · Solare ·  
Solar · Aurinkokenno · Solar



Memory Funktion · Memory function  
fonction mémoire · Geheugen functie ·  
Función de memoria · Funzione memorizzazione ·  
functia memorie · Muistitoiminto · Funkcja pamięci



Akkubetrieb · Rechargeable battery operated  
Fonctionnement sur batteries rechargeable ·  
Oplaadbare accu · Batería recargable ·  
Batteria Ricaricabile · Operabil prin baterie  
reincarabila · Ladattava akku ·  
Akumulator zasilany bateryjnje



Ladezeit · Charging time  
Temps de charge · Oplaadtijd · Tiempo de carga ·  
Tempo di carica · Timp de incarcare · Latausaika ·  
Czas ładowania



Leuchtdauer · Luminous period  
Durée d'éclairage · Brandtijd · Tiempo de  
iluminación · Tempo di durata · Perioada de  
iluminare · Valaistusaika · Czas świecenia



Flammen-Effekt · Flame effect  
Effet de flamme · Vlammeneffect · Efecto de  
llamas · Effetto fiamma · Efect de flacără ·  
Liekkitehoste · Efekt płomienia



Abstrahlwinkel · Emission angle  
Angle de rayonnement · Uitstraalhoek ·  
Ángulo de emisión · Angolo di emissione ·  
Unghiul de emisii · Säteilykulma · Kąt emisji



Belastbarkeit · Resilience  
Limite de charge · Belastbaarheid · Resistencia ·  
Resistenza · Rezistența la solicitare ·  
Kuormitettavuus · Nośność



# Farben & Materialien · Colours and materials

Couleurs et matériaux · Kleuren en materialen · Colores y materiales · Colori e materiali ·  
Culori si materiale · Värit ja materiaalit · Kolory i materiały

## 01 weiß · white

blanc · wit · blanco · bianco · alb · valkoinen · biały

## 02 schwarz · black

noir · zwart · negro · nero · negru · musta · czarny

## 07 Nickel matt · nickel mat

nickel mat · nikkel mat · níquel mate · nichel opaco ·  
nichel mat · harjattu teräs · nikiel mat

## 11 grau · grey

gris · grijs · gris · grigio · gri · harmaa ·  
popielaty · gri

## 24 rostfarbig · rusty

rouille · roestkleur · óxido · ruggine · ruginiu ·  
rustiikki · miedź

## 26 braun · brown

brun · bruin · marron · marrone · maro ·  
ruskea · brązowy

## 28 rostfarbig antik · antique rust

rouille antique · roestkleur antiek · oxido ·  
ruggine anticato · ruginiu antic · rustiikki ·  
antyczny rdzawy

## 30 holzfarbig · wood coloured

couleur bois · houtkleur · color maderá · colore di legno ·  
culoare lemn · puunvärinen · kolor drewna · ahşap renk

## 31 weiß matt · white mat

blanc mat · wit mat · estera blanca · bianco opaco ·  
alb mat · valkoinen matto · biały mat

## 32 schwarz matt · black mat

noir mat · mat zwart · estera negra · nero opaco ·  
negru mat · musta matto · czarny mat

## 42 anthrazit · anthracite

antracite · antraciet · antracita · antracite · antracit ·  
antrasiitti · antracyt

## 44 Beige · fawn

beige · beige · beige · beige · bej · beige · bez

## 62 Kupfer antik · antique copper

cuivre ancien · antiek koper · cobre antiguo ·  
rame antico · cupru antic · antiikki kupari ·  
antyczne miedzi · antik bakır

## 78 betonfarbig · concrete look

couleur beton · beton kleur · color concreto ·  
calcestruzzo · culoare beton · konkreettisia väri ·  
konkretny kolor

## 86 zinkfarbig · zinc-colored

couleur zinc · zink kleur · color zinc · color zinco ·  
culoarea Zincului · sinkki · kolor cynkowy

## 87 titanfarbig · titan

titane · titaan · titán · titano · titaniu ·  
titaani · tytanowy

## 88 silber antik · antique silver

argent antique · antiek zilver · plateado antiquo ·  
argento anticato · argint antic · antiikkihopea ·  
antyczne srebro

Seite Page	Artikel-Nr. Product No.	EAN-Nummer EAN-Number
12	273360142	4017807492750
12	473360442	4017807492767
12	473369442	4017807492781
14	226260142	4017807492545
14	426260142	4017807492576
14	526260142	4017807492569
16	222360142	4017807384321
16	422360142	4017807384338
16	522360142	4017807384345
18	226160142	4017807490442
18	426160142	4017807490466
18	526160142	4017807490459
20	220760142	4017807259063
20	420760142	4017807259087
20	520760142	4017807259100
22	221760142	4017807303551
22	421760142	4017807303582
22	521760142	4017807303575
23	221769142	4017807303568
24	221660242	4017807291544
24	221669242	4017807297614
24	421660242	4017807291551
24	521660242	4017807291568
26	220360142	4017807241648
26	420360142	4017807241655
26	520360142	4017807241662
28	221260142	4017807281484
28	421260142	4017807281507
28	521260142	4017807281521
29	221269142	4017807279665
30	222060142	4017807337624
30	422060142	4017807337648
30	522060142	4017807337631
32	222160142	4017807377323
32	422160142	4017807377347
32	522160142	4017807377330
33	422167142	4017807445398
34	223669142	4017807408492
34	423669142	4017807408515
34	523669142	4017807408508
36	221169142	4017807279290
36	421169142	4017807279306
36	521169142	4017807279313
38	221160142	4017807302004
38	421160142	4017807351583
38	521160142	4017807351590
40	225369142	4017807481525
40	425369142	4017807481570
40	525369142	4017807481556
42	225360142	4017807481501
42	425360142	4017807481563
42	525360142	4017807481549

Seite Page	Artikel-Nr. Product No.	EAN-Nummer EAN-Number
44	226369142	4017807492354
44	426369142	4017807492392
44	526369142	4017807492378
46	226360142	4017807492347
46	426360142	4017807492385
46	526360142	4017807492361
48	220260142	4017807241617
48	420260142	4017807241624
48	520260142	4017807241631
50	204260242	4017807453171
50	204269242	4017807453195
50	404260142	4017807453232
50	504260142	4017807453218
52	206060142	4017807490480
52	406060142	4017807490503
52	506060142	4017807490497
54	228460242	4017807284164
55	221460142	4017807490473
56	229360242	4017807242164
56	229360287	4017807242171
58	227560231	4017807337570
58	227560242	4017807337594
58	227560287	4017807346138
58	227660231	4017807337600
58	227660242	4017807337617
58	227660287	4017807346145
59	226460231	4017807415605
59	226460242	4017807415612
59	226460287	4017807415629
60	226960231	4017807382259
60	226960242	4017807382266
60	226960287	4017807382273
61	226560242	4017807408539
62	226860231	4017807382822
62	226860242	4017807382839
62	226860287	4017807387971
64	227860231	4017807298604
64	227860242	4017807298611
65	228560242	4017807356984
66	220960142	4017807259308
66	220960187	4017807259322
67	220969142	4017807259315
67	220969187	4017807259339
68	228760101	4017807279269
68	228760142	4017807279276
69	620160142	4017807274905
70	226660242	4017807388893
70	226669242	4017807388817
71	227360142	4017807369229
72	228260101	4017807279528
72	228260142	4017807279535
74	229160142	4017807242126

Seite Page	Artikel-Nr. Product No.	EAN-Nummer EAN-Number	Seite Page	Artikel-Nr. Product No.	EAN-Nummer EAN-Number
75	227160242	4017807369335	107	227460131	4017807369205
76	222969131	4017807491296	107	227460188	4017807369212
76	222969142	4017807491272	108	207269124	4017807492613
76	222969231	4017807491357	108	207269131	4017807492620
76	222969242	4017807491371	108	207269142	4017807492637
78	222960131	4017807491234	110	207360142	4017807492675
78	222960142	4017807491258	110	407360142	4017807492729
78	222960231	4017807491319	110	507360142	4017807492705
78	222960242	4017807491326	112	209660130	4017807492798
80	228360101	4017807279603	112	409660130	4017807492828
80	228360142	4017807279610	112	509660130	4017807492804
82	227760142	4017807303537	114	201860130	4017807492859
83	228669142	4017807356656	114	401860130	4017807492897
84	228060101	4017807281552	114	501860130	4017807492873
84	228060142	4017807281569	116	201860142	4017807433210
85	228960101	4017807259124	116	201860242	4017807442410
85	228960142	4017807259131	116	401860142	4017807433258
86	227260142	4017807369236	116	501860142	4017807433234
87	222860142	4017807492590	116	601860242	4017807442397
88	676960131	4017807453393	118	201860186	4017807433227
88	676960142	4017807453416	118	201860286	4017807442427
90	676160224	4017807453430	118	401860186	4017807433265
90	676160278	4017807453447	118	501860186	4017807433241
92	222260124	4017807410594	118	601860286	4017807442403
92	222260224	4017807410587	120	204160142	4017807413946
92	422260124	4017807410570	120	404160142	4017807413960
92	522260124	4017807410563	120	504160142	4017807413991
94	222260142	4017807382570	121	204160131	4017807492408
94	222260242	4017807382587	122	204160124	4017807413939
94	422260142	4017807382600	122	404160124	4017807413953
94	522260142	4017807382594	122	504160124	4017807413977
96	224060142	4017807434330	124	204169124	4017807492446
96	224060242	4017807434347	124	204169131	4017807492422
96	424060142	4017807434361	124	204169142	4017807492460
96	524060142	4017807434354	126	202360142	4017807442069
97	424067142	4017807445404	126	402360142	4017807453119
98	220060142	4017807241501	126	502360142	4017807453096
98	220060242	4017807241525	128	202360124	4017807449891
98	420060142	4017807241792	128	402360124	4017807453102
98	520060142	4017807241563	128	502360124	4017807453072
100	220060187	4017807241518	130	201760124	4017807442021
100	220060287	4017807241532	130	201760142	4017807445411
100	420060187	4017807241808	130	201760186	4017807442038
100	520060187	4017807241570	132	301760124	4017807447309
102	221560142	4017807282375	132	301760142	4017807447323
102	421560142	4017807282399	132	301760186	4017807447354
102	421560242	4017807282405	134	201960124	4017807442045
104	204960142	4017807445169	134	201960142	4017807442052
104	404960142	4017807445176	135	201360124	4017807442007
106	220160142	4017807241587	135	201360142	4017807442014
106	420160142	4017807241594	136	221967128	4017807331196
106	520160142	4017807241600	136	221969128	4017807331219

Seite Page	Artikel-Nr. Product No.	EAN-Nummer EAN-Number
137	202760124	4017807445589
137	202760142	4017807449884
137	202760178	4017807445602
138	251060131	4017807491395
138	251060142	4017807491401
139	251160131	4017807491432
139	251160142	4017807491456
140	821660107	4017807453287
140	821669107	4017807453300
141	821660207	4017807453348
141	821669207	4017807453379
142	551753001	4017807407440
142	551754001	4017807407457
145	800260142	4017807453133
145	800260342	4017807453157
146	9961-11	4017807305777
146	9962-11	4017807305784
146	9963-11	4017807305791
147	9964-42	4017807445299
148	9960-07	4017807259360
149	9965-32	4017807472349
152	R28211107	4017807370898
152	R28212107	4017807370973
154	R28222631	4017807408324
154	R28222632	4017807411775
155	R28232631	4017807408317
155	R28232632	4017807411768
156	R28200642	4017807296952
157	R22052142	4017807490428
157	R22062142	4017807490435
158	R22151131	4017807453492
158	R22151142	4017807453546
158	R62151131	4017807405941
158	R62151142	4017807405989
160	R60501031	4017807405873
160	R60501042	4017807405910
160	R60502031	4017807405927
160	R60502042	4017807405934
164	R45101101	4017807500295
164	R45101901	4017807500301
164	R55101101	4017807500271
166	R55060101	4017807430578
167	R55086101	4017807444421
168	R57080101	4017807407556
169	R57090101	4017807407563
170	R55096101	4017807492200
172	R57010101	4017807279948
172	R57020101	4017807279955
173	R57051101	4017807382518
173	R57071101	4017807325348
174	R42096142	4017807467116
174	R52096142	4017807467031

Seite Page	Artikel-Nr. Product No.	EAN-Nummer EAN-Number
175	R52176101	4017807496314
175	R52176102	4017807496338
176	R57042001	4017807282801
176	R57043001	4017807282818
176	R57044001	4017807282825
180	R22251142	4017807452686
180	R42251142	4017807452709
182	R22261142	4017807452723
182	R42261142	4017807452730
184	R22241142	4017807452662
184	R22281142	4017807452754
185	R22231107	4017807458220
185	R22231142	4017807452648
186	R55256101	4017807492040
186	R55256111	4017807492064
186	R55256901	4017807492088
186	R55256911	4017807492095
188	R55276144	4017807492002
188	R55276944	4017807492026
190	R55296142	4017807492286
191	R55266131	4017807492309
191	R55266188	4017807492323
192	R55316132	4017807492262
193	R55286162	4017807492224
193	R55286188	4017807492248
194	R55146132	4017807452792
194	R55196126	4017807452907
195	R55136132	4017807452778
196	R55156132	4017807452815
196	R55166132	4017807452822
197	R55176132	4017807452853
198	R55326101	4017807492101
198	R55326901	4017807492125



### **TRIO Leuchten GmbH**

Gut Nierhof 17  
D-59757 Arnsberg

T +49 2931 9666-0  
F +49 2931 9666-57

info@trio-leuchten.de  
www.trio-leuchten.de



### **Reality Leuchten GmbH**

Gut Nierhof 17  
D-59757 Arnsberg

T +49 2931 9666-99  
F +49 2931 9666-98

info@reality-leuchten.de  
www.reality-leuchten.de

### **NIEDERSACHEN, SCHLESWIG-HOLSTEIN, HAMBURG, BREMEN**

#### **Jens Gebers**

T +49 170 1615227  
jens.gebers@trio-leuchten.de

### **BERLIN, BRANDENBURG, MECKL.-VORPOMMERN, SACHSEN, SACHSEN ANHALT, THÜRINGEN**

#### **Jörg Bumke**

T +49 160 7406860  
joerg.bumke@trio-leuchten.de

### **NORDRHEIN-WESTFALEN**

#### **Antonio Capizzi**

T +49 172 2598392  
capizziantonio@aol.com

### **SAARLAND, RHEINLAND-PFALZ, HESSEN**

#### **Christian Teller**

T +49 171 4521820  
christian.teller@trio-leuchten.de

### **ÖSTERREICH**

#### **Wolfgang Melich**

T +43 660 5161228  
wolfgang.melich@trio-leuchten.de

### **BADEN WÜRTTEMBERG**

#### **Antonio De Simone**

T +49 151 58555222  
antonio.desimone@trio-leuchten.de

### **SCHWEIZ**

#### **Andreas Huber**

T +41 76 316 22 89  
andreas.huber@trio-leuchten.ch

### **BAYERN, HESSEN**

#### **Martin Kluge**

T +49 171 7300330  
martin.kluge@trio-leuchten.de

## TRIO International GmbH

Gut Nierhof 17  
D-59757 Arnsberg  
T +49 2931 9666-587  
F +49 2931 9666-56  
info@trio-lighting.com  
www.trio-lighting.com

## FRANCE

### Stéphane Papierny

Directeur Commercial France  
info.france@trio-lighting.com

### Jean Philippe Bailly

info.france@trio-lighting.com  
Agent exclusif pour les départements  
60, 75001-75004, 75008-75010,  
75017-75019, 92, 93, 95

### Jean Barel

info.france@trio-lighting.com  
Agent exclusif pour les départements  
09, 12, 15, 16, 19, 23, 24, 31, 32, 33, 40,  
46, 47, 64, 65, 81, 82 et 87

### Nina & Richard Lecoiffier

info.france@trio-lighting.com  
Agents exclusifs pour les départements  
27, 28, 76

### Antoine Masu

info.france@trio-lighting.com  
Agent exclusif pour les départements  
2a et 2b

### Christophe Meulien

info.france@trio-lighting.com  
Agent exclusif pour les départements  
04, 05, 06, 11, 13, 30, 34, 66, 83 et 84

### Stéphane Riebel

info.france@trio-lighting.com  
Agent exclusif pour les départements  
18, 45, 58, 75005-75007, 75011-75016,  
75020, 77, 78, 89, 91, 94

### Michel Salamand

info.france@trio-lighting.com  
Agent exclusif pour les départements  
14, 17, 22, 29, 35, 36, 37, 41, 44, 49, 50,  
53, 56, 61, 72, 79, 85 et 86

### Vincent Zaepffel

info.france@trio-lighting.com  
Commercial pour les départements  
02, 08, 10, 25, 51, 52, 54, 55, 57, 59, 62,  
67, 68, 70, 80, 88 et 90

### Sullivan Nicolas

info.france@trio-lighting.com  
Agent exclusif pour les départements  
01, 03, 07, 21, 26, 38, 39, 42, 43, 48, 63,  
69, 71, 73 et 74

## NEDERLAND

### Karl Stok / Bas Martin

info.nederland@trio-lighting.com

## BELGIUM/BELGIQUE

### Yves van den Berghe

info.belgium@trio-lighting.com

## ITALIA

### TRIO Lighting Italia s.r.l

Via Padre Masciadri, 2 H  
IT-22066 Mariano Comense (CO)  
T +39 317 477 55  
F +39 313 551 560  
commerciale@trio-lighting.com

## ESPAÑA

### TRIO Lighting Ibérica SL

C/ Can Lietget n°9 nave9  
Pol. Ind. Can Roqueta  
08206 Sabadell  
T +34 9 35 45 86 30  
F +34 9 33 96 45 48  
info.iberica@trio-lighting.com

## SUOMI

### TRIO Lighting Scandinavia Oy

Malmin raitti, rappu 17 B  
00700 Helsinki  
T +358 10 23 13 390  
F +358 10 23 13 399  
info.scandinavia@trio-lighting.com  
Our Scandinavian organisation represents TRIO  
also in DENMARK, SWEDEN, NORWAY, ESTONIA,  
LATVIA and LITHUANIA

## GREAT BRITAIN

### TRIO Lighting UK Ltd.

Unit 5, Hemmells Park Hemmells, Laindon  
Essex  
SS1s 6GF  
T +44 12 68 88 95 95  
F +44 12 68 88 95 96  
sales@triolightinguk.com

## ROMANIA

### Gina Ionita

info.romania@trio-lighting.com

# Notizen · notes

A series of horizontal dashed lines for writing notes.







## **TRIO Leuchten GmbH**

Gut Nierhof 17  
D-59757 Arnsberg  
T +49 2931 9666-0  
F +49 2931 9666-28  
info@trio-leuchten.de  
www.trio-leuchten.de

## **Reality Leuchten GmbH**

Gut Nierhof 17  
D-59757 Arnsberg  
T +49 2931 9666-99  
F +49 2931 9666-98  
info@reality-leuchten.de  
www.reality-leuchten.de

## **TRIO International GmbH**

Gut Nierhof 17  
D-59757 Arnsberg  
T +49 2931 9666-587  
F +49 2931 9666-56  
info@trio-lighting.com  
www.trio-lighting.com

 @trioleuchten

 /trioleuchten

 @trio.lighting

